

F4 节能平缝机 产品使用说明书 F4 Power saving lockstitch sewing machine

使用说明和零件样本下载地址：
PLEASE DOWNLOAD THE MANUAL AND SPARE PARTS FROM THE FOLLOWING WEBSITE:
ÇANLIÇA FİLAĞA ADEE ÇABÜAÖEÇE AA×O ÇABEİA İE ÇABEÖ ÇABÇAE:
POR FAVOR DESCARGAR EL MANUAL Y LIBRO DE PARTES Y REPUESTOS LO SIGUIENTE EN SITIO WEB:
Пожалуйста, загрузите инструкцию по эксплуатации и деталировку (список запасных частей) со следующего вебсайта:
http://download.chinajack.com
产品标准代号: QB/T2256-2006
Standard code of the products: QB/T2256-2006

杰克缝纫机

JACK SEWING MACHINE
HTTP://WWW.CHINAJACK.COM

杰克缝纫机股份有限公司

JACK SEWING MACHINE CO., LTD.

- 公司地址 (Address of Company):
台州市椒江区机场南路十五号
No.15 Rd Airport South, Jiaojiang District Taizhou City, Zhejiang, P.R.C
邮编: 318000
- 国内销售部 (Domestic Trade Department):
电话 (TEL): 0086-0576-88177788 88177789
传真 (FAX): 0086-0576-88177758
- 国际贸易部 (International Trade Department):
电话 (TEL): 0086-0576-88177782 88177774
传真 (FAX): 0086-0576-88177787
- 免费售后服务电话: 400-8876858
http://www.chinajack.com
- 资料如有更改, 恕不另行通知, 以实物为准。
You will be not informed if the file has been revised. Please set sample as standard

使用说明 Operation Manual

开车前的注意事项: BEFORE OPERATION

- 油盘内未加油绝对不能开车。
- 机器运转时, 从外侧转向应为逆时针方向。注意, 不能倒转。
- 确认标准上标的电压是否正确。

- Never operate the machine unless its oil pan has been filled with oil.
- After setting up the machine, check the direction of motor rotation. To check it, turn the handwheel by hand to bring the needle down, and turn the power switch ON while observing the handwheel. (The handwheel should turn counterclockwise as observed from the handwheel side.)
- Confirm that the voltage and phase (single or 3-phase) are correct by checking them against the ratings shown on the motor nameplate.

使用注意事项: OPERATION PRECAUTIONS

- 接通电源开关或机器运转时, 请勿将手放到针的下部。
 - 机器运转时, 请勿将手指伸入挑线杆护罩内。
 - 机头启动时, 一定要切断电机开关。
 - 操作者离开机器时, 必须切断电源。
 - 机器运转期间, 注意不允许任何人的头或者手以及任何东西靠近绕线轮和手轮。
 - 装拆防护罩或者其它保护装置时, 请勿开动机器。
 - 不要用香蕉水等油漆稀释剂清洗机头表面。
- Keep your hands away from the needle when you turn the power switch ON or while the machine is operating.
 - Do not put your fingers into the thread take-up cover while the machine is operating.
 - Be sure to turn the power switch OFF before tilting the machine head or removing the V belt.
 - When an operator leaves from the machine, make sure to turn off the power.
 - During operation, be careful not to allow your or any other person's head or hands to come close to the bobbin winder or handwheel. Also do not place anything close to them. Doing so may be dangerous.

- If your machine is provided with a belt cover, finger guard or any other protectors, do not operate your machine with any of them removed.
- Don't clean the face of machine head with thinner.

1. 机器的安装 (图 1、图 2、图 3、图 4) 1. INSTALLATION (Fig.1, Fig.2, Fig.3, Fig.4)

- *油盘安装:
- 先将油盘支架①和油盘垫座②分别套在油盘③的四角上, 再将油盘③安装在台板上。
 - 如图所示, 安装时要确保两个油盘支架①朝向操作者一边, 两个油盘垫座②是在有机头连接钩座④的那一侧。
 - 先将机头连接钩座④安装在台板上, 再将机头连接钩⑤放入底板孔内, 最后将机头放置于台板上, 且机头连接钩⑤要与台板上的机头连接钩座④相融合。
- *Installing the oil pan
- Firstly, oil pan holder① and Oil pan cushion② should be set in the four corners of the oil pan③, and then install the oil pan③ on the stand & table.
 - As is shown in the chart, making sure that the two oil holders① are pointing to the operator during the installation and the two oil pan cushions② are on the side which is with machine head connecting hook④.
 - Install the machine head connecting hook base④ on the stand & table, and then put the machine head connecting hook⑤ in the baseplate hole, at last, put the head on the stand & table, making sure machine head connecting hook⑤ is nested in the machine head connecting hook base④ which is on the stand & table.

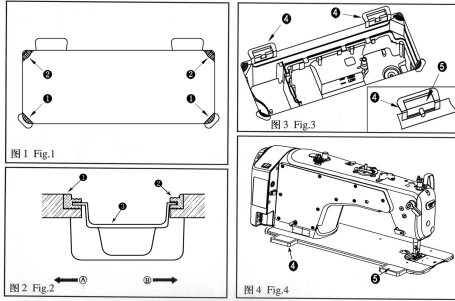

• 3 •

2. 机器的润滑 (图 5、图 6) 2. LUBRICATION (Fig.5, Fig.6)

1. 润滑须知: (图 5)
- *开车前:
- 向油盘①内加缝纫机油 (10号白油) 至 HIGH 记号部位 A。(图 5)
 - 当油面低于 LOW 记号 B, 应再加油。
 - 加油后, 开动机器, 应看到油飞溅到油窗②上, 说明润滑正常。
 - 至于飞溅的油量多少与总润滑油量多少无关。
- *注意:
使用新机器或者长期未使用过的机器时, 应在每分钟 1800~2200 转的状态下使机器进行 10 分钟左右的适应性运转。
1. Information on lubrication (Fig.5)
- *Before starting the machine
- Fill oil pan ① with sewing machine oil (10 white oil) up to HIGH mark A.
 - When the oil level lowers below LOW mark B, refill the oil pan with the specified oil.
 - When you operate the machine after lubrication, you will see splashing oil through oil sight window ② if the lubrication is adequate.
 - Note that the amount of the splashing oil is unrelated to the amount of the lubricating oil.
- *Precaution
When you first operate your machine after set up or for an extended period of disuse, run your machine at 1,800 s.p.m. to 2,200 s.p.m. for about 10 minutes for the purpose of break-in.
2. 面部油量采用油线添油的方法: (图 6)
2. The amount of oil supplied to the face plate parts apply the plug of main shaft to control (Fig.6)

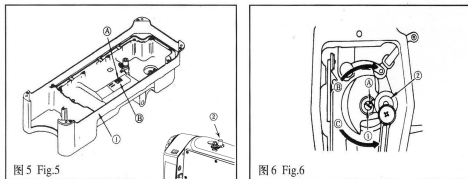

• 4 •

3. 面线的穿法 (图 7) 3. THREADING THE MACHINE HEAD (Fig.7)

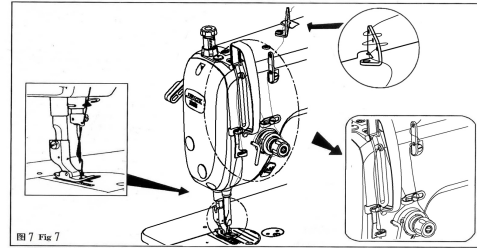

4. 缝线张力 (图 8) 4. THREAD TENSION (Fig.8)

- 面线张力的调节:
根据不同的缝制条件, 用夹线螺母来调整面线张力。
若把螺母①按顺时针方向 (即 A 方向) 转动时, 面线张力将增大。
若把螺母①按逆时针方向 (即 B 方向) 转动时, 面线张力将减小。
 - 底线张力的调节:
将夹线螺钉②朝顺时针方向 (即 C 方向) 转动时, 底线张力将增大。
将夹线螺钉②朝逆时针方向 (即 D 方向) 转动时, 底线张力将减小。
1. Adjusting the needle thread tension
- Adjust the needle thread tension using tension adjust nut ① according to the sewing specifications.
 - As you turn nut ① clockwise (in direction A), the needle thread tension will increase.
 - As you turn nut ① counterclockwise (in direction B), the tension will decrease.

2. Adjusting the bobbin thread tension

- As you turn tension adjust screw ② clockwise (in direction C), the bobbin thread tension will increase.
- As you turn screw ② counterclockwise (in direction D), the bobbin thread tension will decrease.

5. 挑线簧 (图 9) 5. THREAD TAKE UP SPRING (Fig.9)

- 改变挑线簧①的摆动量:
旋松定位螺钉②。
把夹线螺钉③朝顺时针方向 (即 A 方向) 转动时, 挑线簧的摆动量将增大。
把夹线螺钉朝逆时针方向 (即 B 方向) 转动时, 挑线簧的摆动量将减小。
 - 改变挑线簧①的张力:
旋松定位螺钉②, 取出夹线器 (组件) ③。
旋紧定位螺钉③, 并转动夹线螺钉③。
把夹线螺钉③朝顺时针方向 (即 A 方向) 转动时, 挑线簧的张力将增大。
把夹线螺钉③朝逆时针方向 (即 B 方向) 转动时, 挑线簧的张力将减小。
1. Changing the stroke of thread take-up spring ①
- Loosen setscrew ②.
 - As you turn tension post ③ clockwise (in direction A), the stroke of the thread take-up spring will be increased.
 - As you turn the knob counterclockwise (in direction B), the stroke will be decreased.
2. Changing the pressure of thread take-up spring ①
- Loosen setscrew ②, and take out tension asm ③.
 - Loosen setscrew ③, and remove tension post ③.
 - As you turn tension post ③ clockwise (in direction A), the pressure will be increased.
 - As you turn the post counterclockwise (in direction B), the pressure will be decreased.

6. 针与旋梭的关系 (图 10) 6. THE RELATION BETWEEN THE NEEDLE AND THE HOOK (Fig.10)

- 针与旋梭的关系应配合如下:
- 转动上轮, 使针位于最低点, 再旋松针杆连接柱定位螺钉①。
 - 针杆高度的确定
拉动针杆, 水平透过内梭内边缘可看到针孔有 1/3~1/2 漏出 (机针必须安装到位), 机针挑线槽朝左, 然后旋紧针杆连接柱螺钉。
 - 旋梭位置的确定
旋梭旋梭紧固螺钉, 让旋梭钩线尖②对准机针③的中心线, 此时转动上轮, 使旋梭钩线尖位于针孔上缘上方 1~1.5mm 处。
 - 在上述状态下, 左右移动旋梭, 使机针与旋梭的横向间隙为 0~0.05mm, 然后拧紧旋梭紧固螺钉。

• 6 •

- *注意: 若间隙太小, 会磨损梭尖, 若间隙太大, 则会引起跳针。
*旋梭原来用什么型号, 调换后, 也请使用原来的型号。
The relation between the needle and the hook should be as follows;
1) Turn the pulley, make the needle stay the lowest point, then loosen the screw (1).
2) The height of the needle bar Pull the needle bar, you can see the pinhole baset 1/3~1/2 level through edge of inside hook (needle must be position). Turn needle cover wire slot left, then tighten setscrew.
3) The hook position
Loosen the hook and tighten the screw, make the top of the thread eyelet aim at the middle thread of the needle(2). Then turn the pulley, make the thread eyelet top locate above the needle hole about 1mm~1.5mm.
4) In the above situation, remove the hook left and right, make the horizontal gauge between the needle and hook about 0~0.05mm then.
* Preaution
If the clearance is too small, the tip of the hook will be abraded. If it is too big, it will lead to skip over.
* Note that the type of hook to be substituted for, when replacing the hook, shall be in conformity with the very type of the hook installed in the sewing machine of original assemblage.

7. 踏板压力和行程 (图 11) 7. PEDAL PRESSURE AND PEDAL STROKE (Fig.11)

- 踏板踩踏压力的调整
1) 旋松踏板弹簧①的位置, 可调整踩踏压力。
2) 把弹簧挂到左侧之后, 压力变轻。
3) 挂到右侧之后变重。
 - 踏板回弹力的调整
1) 用踏板回弹力调节器②可以调整。
2) 逆时针调节螺丝则压力变大。
3) 顺时针调节螺丝则压力变小。
3. 踏板踩踏行程的调整
1) 把连接杆③插到右侧的孔里之后行程变大。
- 1 Adjusting the pressure required to depress the front part of the pedal
1) This pressure can be changed by changing the mounting position of pedaling pressure adjust spring ①.
2) The pressure decreases when you hook the spring on the left side.
3) The pressure increases when you hook the spring on the right side.
- 2 Adjusting the pressure required to depress the back part of the pedal
1) This pressure can be adjusted using regulator screw ②.
2) The pressure increases as you turn the regulator screw in.
3) The pressure decreases as you turn the screw out.
- 3 Adjusting the pedal stroke
1) The pedal stroke increases when you insert connecting rod ③ into the right hole

8. 膝提高度的调节 (图 14、图 15) 8. ADJUSTING THE HEIGHT OF THE KNEE LIFTER (Fig.26, Fig.27)

- 用膝提升的标准压脚高度是 10 毫米。
- 用膝提升调整螺钉①可以调节压脚提升量至 13 毫米。
- 当压脚提升超过 10 毫米时, 不能使处于最低位置的针杆②的底端与压脚③相碰。
1) The standard height of the presser foot lifted using the knee lifter is 10 mm.
2) You can adjust the presser foot lift up to 13 mm using knee lifter adjust screw ①.
3) When you have adjusted the presser foot lift up to over 10 mm, be sure that bottom end of needle bar ② in its lowest position does not hit presser foot ③.

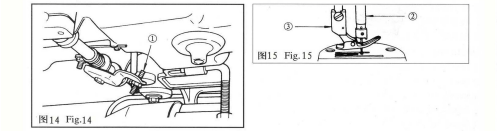

9. 规格 9. SPECIFICSTIONS

用途	一般布料、薄料、中厚料	中厚料、厚料
缝纫速度	最高 4,000rpm	最高 3,500rpm
最大针脚长度	5mm	
机针	DBx1 #11~#18(#14)	DPx5 #16~#24(#21)
压脚高度 (膝动提升)	10mm (标准) 13mm (最大)	10mm (标准) 13mm (最大)
使用机油	New Defrix Oil No.10 机油	
噪音	根据噪声测量标准: DIN 45635-48-A-1 在转速 4000 r/min 时, 工作场所噪音 L _A ≤ 83 dB(A)	
Application	General fabric, light-weight and medium-weight materials	Medium-weight materials, Heavy-weight materials
Sewing speed	Max. 4,000 rpm	Max. 3,500 rpm
Max. Stitch length	5mm	
Needle	DBx1 #11~#18(#14)	DPx5 #16~#24(#21)
Presser foot lift	10mm (standard) 13mm (Max.)	10mm (standard) 13mm (Max.)
Lubricating oil	New Defrix Oil No.10	
Noise	Workplace-related noise at sewing speed N=4,000 min ⁻¹ ; L _A ≤ 83 dB(A) Noise measurement according to DIN 45635-48-A-1	

• 8 •