

Automatic placket setting machine

Operating instructions

Part 1 Operating instructions



Hint

These operating instructions contain all information required for the operation of the machine. It addresses to the operator of the machine, that is the person that works at and with the machine. Please obtain all rules and regulations.

Contents

Page

Part 1 Operating instructions

General security advice and warning hints	3
Transportation.....	3
Storage.....	3
Installation	4
1 Introduction	5
1.1 Description of the machine	5
1.2 Technical data.....	5
2 Main parts of the machine.....	6
3 Security	7
3.1 Available security systems.....	7
3.1.1 Program stop button (STOP)	7
3.1.2 Mains /emergency stop button.	7
3.2 Security measures of the operator.....	7
4 Operation of the machine	7
4.1 Controls and indicators	7
4.1.1 Operation penal.	8
4.1.2 Insertion station.	10
4.1.3 Mains / emergency stop button	10
4.1.4 Foot pedal machine sequence.	10
4.1.5 Return the presser	11
4.2 Operation	12
4.2.1 Machine sequence	12
4.2.2 Program operation	12
5 Required cleanings	13

General security advice and warning hints

1. Danger might arise for persons, things and environment by inappropriate operation of this machine. Installation and maintenance duties may only be carried out by authorized staff.
2. Before any operations at or with the machine (putting into operation, operation, maintenance, repair, etc.) the person carrying out has to read and understand this manual with each appendix completely.
3. Before carrying out maintenance or repair duties, the mains supply must be cut off. Additionally pressure must be released from the pneu-matical system.
4. The machine will be destroyed by a connection to a wrong mains voltage! See the section 'Technical data' before connecting the power supply.

Transportation

Generally it is possible to move the machine. Obey the following hints:

1. Cut off the power supply, release the pneumatical pressure.
2. Fix movable and loose parts.
3. Lift the base with a hoisting device and be sure to lift possible additional devices (e.g. stacker). If the machine is equipped with transportation casters (option), you will have to release the brakes at every caster.
4. Move the machine carefully to the new location.

Attention

Attention when moving the machine on sloping areas! Enormous pull power arises from the machine weight.

Storage

If no other agreement is fixed, the following limitations have to be kept:

1. In closed rooms only.
2. Temperature range -10 ... +45 °C.
3. Humidity max. 80% non-condensing.

Attention

If stored or transported in improper environments, the machine can be damaged severely. Damages may not be visible from the outside.

Installation

● Mechanical installation

Unpack and put up

1. Remove the packing material and possible transportation protections.
2. Position the machine on a solid and horizontal ground.
3. Level the machine to a horizontal stand using the adjustable frame feet.

Connection of air supply

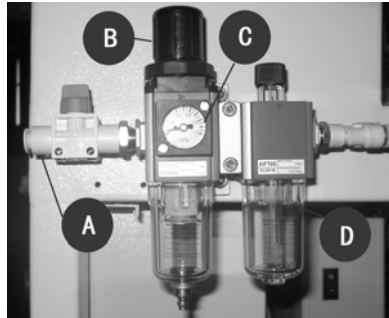

1. Connect the air pipe (A) to your air system.
2. Open the air supply of your air system.
3. Level the air pressure to 6 bar using the control (B); the air pressure can be read at the scale (C).

Attention

We recommend to switch off the air supply when the machine is not in duty. Use the black control (B).

● Elektrical installation

1. Use the power cord located at the backside of the machine.
2. Plug it into a socket.
3. Lay the cord in a way, that the danger of stumbling is avoided.

Hint

Parts under electrical current! Without cutting off the power supply, you might be injured severely. The machine will be destroyed by connecting to a wrong mains voltage! Check, whether the requirements from chapter 'Technical data' meet the local conditions.
Danger to life from insufficient grounding!

● First putting into operation

This machine has been configured to the individual requirements of the customer. The first putting into operation can be done easily:

1. Adjust the machine to a horizontal stand.
2. Connect power and air supply.
3. Switch on the machine using the mains / emergency stop switch at the front side of the machine.
4. Check all security systems for function and efficiency.

As a factory setting, several production programs are contained in the buffer of the machine. You may use one of them or create your own programs.

1 Introduction

1.1 Description of the machine

- Equipped with the large size LCD 640*480, all the functions with easy understanding logo and Chinese/English interpreter, the programming and operating are very easy.
- With many errors warnings, whenever the operation is not correctly completed, the according error number will be displayed, the solutions will be found accordingly.
- With the I/O testing system, all the sensor input and electromagnetic output can be tested separately, so it is easy to find the exact problem when the machine not working.
- Placket sewing and cutting in one step, effectively reduce the wrinkle of the bottom. Single needle direct-drive sewing machine head is with the automatic functions of thread trimmer, thread broken detect, foot lifter, backtack, etc.
- Working table is with laser lights positioning device, make the operation more easier.
- Using three axes linkage(machine head rotation, machine head move left and right, presser foot move forward and backward) to stitch, in the certain area can stitch all types design, so it is able to stitch all types plackets.

1.2 Technical data

Stitch Density	1.0~5.0mm
Backtack stitch numbers	0~10
Seam Length	10~280MM
Seam width	1~50mm
Sewing Speed	500~4000RPM
Language	Chinese, English
Pattern numbers	50
Cycle Sewing	Up to 6 preset for each program
Needle Style	DB*1 11#
Electrical Requirements	220 V, 50/60Hz, single phase, Consumption 0.6kw
Req. air pressure	0.6Mpa
Dimensions	2,100 x 1,000x 1,450mm (L x W x H)
Weight	200kg

2 Main parts of the machine

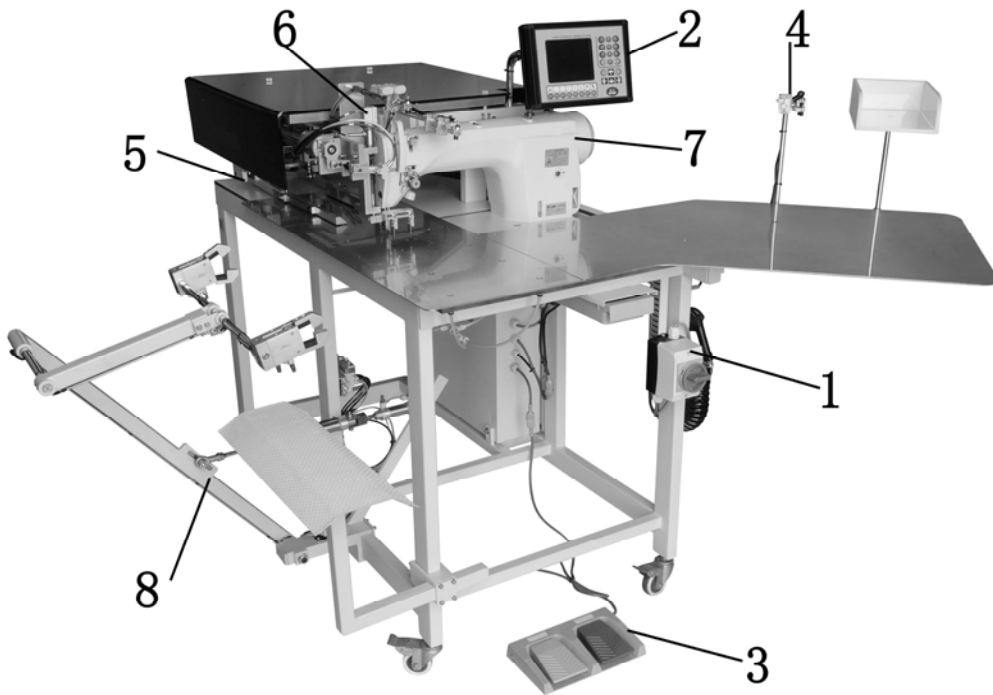

No.	Name	No.	Name
1	Power switch	5	Feeding presser foot
2	Operation panel	6	Centre knife mechanism
3	Foot pedal	7	Sewing machine head
4	Laser positioning light	8	Stacker

Stitch sample:

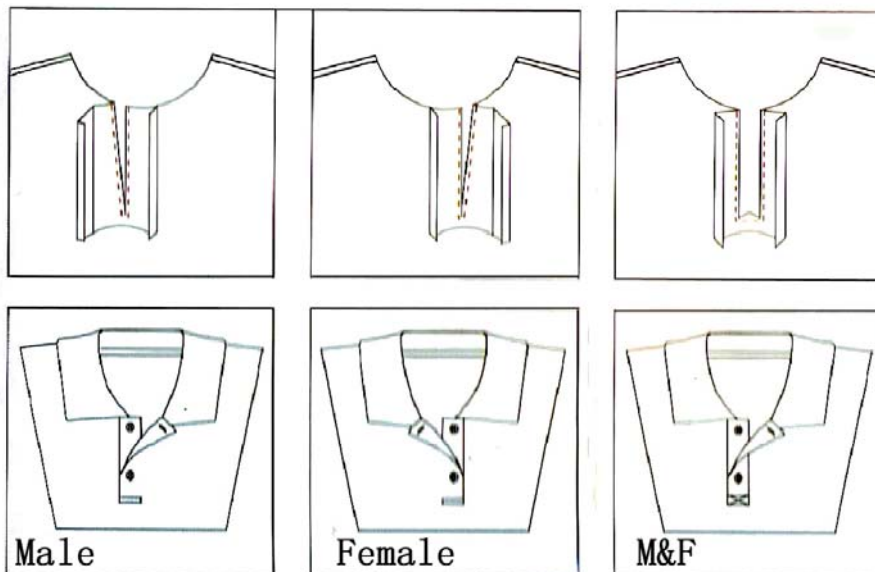

3 Security

3.1 Available security systems

3.1.1 Program stop button (STOP)

The program stop button is mounted in the right down corner of the operation device. After pressing, all movements and the sewing process will be stopped immediately.

3.1.2 Mains /emergency stop button

The mains / emergency stop switch is mounted on the front side of the machine, right-handed below the working plate. It can be used to cut-off the power supply.

3.2 Security measures of the operator

The security systems of this machine work passively, that means that they can only react on certain incidents. To achieve the required security for your health and that of your colleagues, active measures of the operator are required.

Please obey the following general rules for the use of this machine:

1. Always work concentrated and avoid actions with a risk.
2. Don't try to bridge existing security systems or to disable them in any way.
3. Check all security systems on function and effectivity before starting work.
4. Cut off the power supply before opening the switchbox.
5. Switch off the machine with the mains / emergency stop switch, before executing cleaning and maintenance duties.

4 Operation of the machine



This machine may only be operated by qualified staff, who had read and understood this operating manual completely.

4.1 Controls and indicators

- A Operation pedal
- B Insertion station
- C Mains / emergency stop button
- D Foot pedal
- E Return the presser

4.1.1 Operation panel

During production the machine can be operated with the operating panel; existing programs can be called and new programmed.

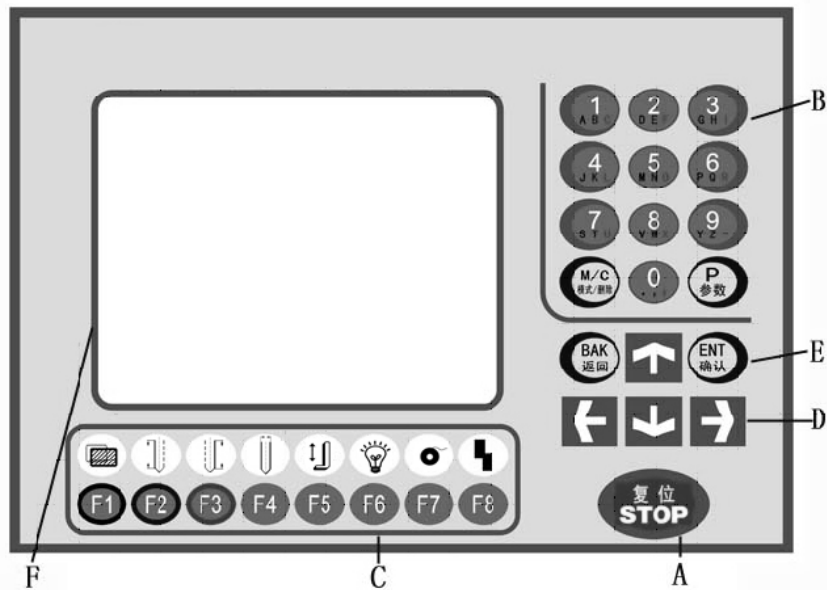

A: Program stop button

D: Arrow keys

B: Ten key pad with P-and M-key

E: Enter and back keys

C: Function keys

F: Display

4.1.1.1 Program stop button

















By pressing the program stop button, all movements of the machine will be stopped immediately. To continue production, you have to pressed the program stop button too.

4.1.1.2 Ten key pad with P- key and M/C-key













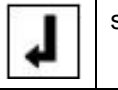



- Numerical inputs can be done using the ten key pad.
- The keys of the ten-key pad are occupied with letters, too. Each letter is shown on its key with a color (blue, orange, green). Press one of the keys F1...F3 together with a number key, to enter the desired letter (F1 blue, F2 orange, F3 green). Examples: A = F1 + 1; N = F2 + 5; U = F3 + 7.
- The P-key is used in several steps of the machine programming.
- Sewing programs can be selected after pressing the M-key.

4.1.1.3 Function keys – lower occupation

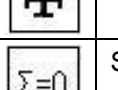
		switches to the upper occupation of the function keys
		Sewing length correction; Select the parameter using the arrow keys. Press the ENT-key, Enter the desired value. then press the ENT-key. Repeat above steps for all desired parameters. Press the BAK-key to leave the menu
		Sewing length correction; Select the parameter using the arrow keys. Press the ENT-key, Enter the desired value. then press the ENT-key. Repeat above steps for all desired parameters. Press the BAK-key to leave the menu
		Sewing width correction: up to 6 steps stitches can be corrected. In the picture showed in LCD, the width between the center line to the left and right is the width of left stitch and right stitch to the center knife.
		Threading. Push once the machine head will move to right back, and presser foot down; push twice the machine head will back to the center position, and presser foot up.
		Turn on the lamp, push once on, push again off.
		Press the ENT-key to manual spooling; Press the BAK-key to cancel manual spooling; Press the STOP-key to stop manual spooling;
		Reset key; use this key to reset the program sequence step by step; sets the clamp into starting position

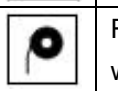
4.1.1.4 Function keys – upper occupation

Press F1 to switch to the upper key occupation. The icons will be displayed in the lower line.

		switches back to the lower key occupation
		Switch middle knife on/off; the knife is switched off, until it will be switched on here.
		Switch stacker on/off; it remains switched off until it will be switched on here
		Laser positioning light 1 on/off.
		Laser positioning light 2 on/off.
		Laser positioning light 3 on/off.
		Sets counter to zero.
		Reset spool thread length; when the spool thread is over, you can display the whole thread length by pressing this key

4.1.1.5 Arrow and Enter/Back keys



Use the arrow keys to move the flashing cursor between the different sections of a display. Confirm inputs using the Enter key.
Press the Bak-key to leave the menu.

4.1.1.6 Display

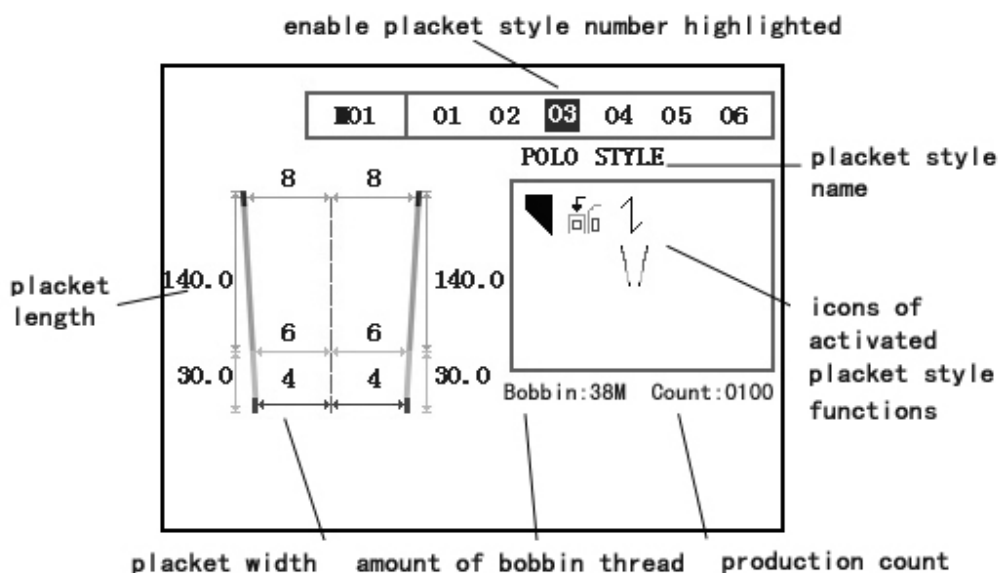

All information required for the operation of the machine will be imaged in the display.

- the graphic on the left side images the current stitching, the number on the left side and right side is the stitch length, the center broken line the knife position, the number on the both side of the broken line the distance of the stitch to the knife.
- the most upper line shows the number of the selected program (M01) and the seams assigned to this program (01, 02, 03, 04, 05 and 06); the code of the current seam is displayed black. The lower letter, like “POLO STYLE” is the program name.
- the square below contains the icons of the machine functions assigned to the current seam
- below the square, the stock of bobbin thread (38 m) and the number of produced parts (100) are displayed

4.1.2 Insertion station

The parts to be manufactured are inserted at the insertion station. Use the marking lamps to align the parts exactly.

4.1.3 Mains / emergency stop button

With the mains / emergency stop button, you can cut-off the power supply of the machine.

4.1.4 Foot pedal machine sequence

4.1.4.1 Function

The left yellow foot pedal is backward pedal. Use this foot pedal to reset the program sequence step by step; sets the clamp into starting position.

The right blue foot pedal is forward pedal. Use this foot pedal to trigger the steps of the machine sequence (see further below).

4.1.4.2 Performing re-sewing

操作中途停止!!!
Stop while in operation!!!
Berhenti ketika proses operasi!!!



踩右踏板使压脚后退
Backward the pressure foot by press the right pedal.
Mundurkan pressure foot dengan menekan pedal sebelah kanan.

When left yellow foot pedal is pressed during sewing operation, the sewing machine interrupts sewing and stops. At this time, error display screen is displayed.

Press right foot pedal to release the error and sewing starts again.

4.1.5 Return the presser

错误 35: 断线
Error35: Thread broken
Error35: Benang putus





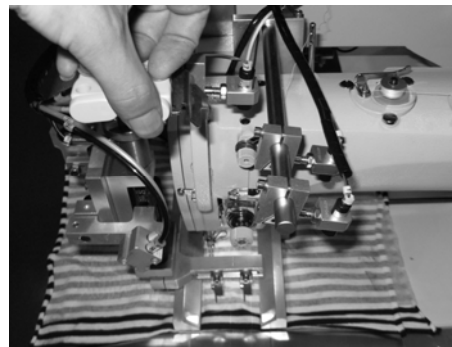



重新穿好线后，按前 / 后补针键回到断线原点位置，踩右踏板继续缝纫。
Put the thread, and press the button of compensate stitch to find the right place of thread broken, and then press the pedal to continue sewing.
Letakkan benang, dan tekan tombol mengganti jahitan untuk menemukan tempat benang putus lalu tekan pedal untuk melanjutkan menjahit.

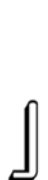

When thread breakage has occurred during machine running, Error display screen 35 is displayed.

Press backward key and the presser returns stitch by stitch. Press forward key and the presser advances stitch by stitch. Return the presser to the re-sewing position. Depress the right side pedal and sewing starts again.

For example:

					
<p>Sewing normally</p>	<p>It is suddenly thread broken while you are sewing at the fourth stitch. But as the Thread Monitor Filter choose 7%, so the press foot need to go to sew 7 stitch, then the press foot will stop.</p>	<p>Press backward key and the press foot returns stitch by stitch.</p>	<p>Press forward key and the press foot advances stitch by stitch.</p>	<p>According to press backward key or forward key until the press foot stay at right place.</p>	<p>After the needle thread is OK, please press the foot pedal, then the the machine will keep moving from thread broken place, until finish sewing.</p>

4.2 Operation

4.2.1 Machine sequence

The production sequence is divided into several parts:

1. Machine sequence can start, if the machine is in starting position.
2. Insert the parts to be sewed and align them exactly.
3. Press the foot pedal, left/right presser foot down.
4. Press the foot pedal again, the right/left presser foot down.
5. Press foot pedal, the presser foot moving the fabric to the sewing position, machine start to stitch, knife action, stacker action. The operator can trigger each step with a short pressing of the foot pedal, or run an automatic process by keeping the foot pedal pressed. Depending on the programming, different machine sequences might occur.

4.2.2 Program operation

The machine is operated with programs, which can be selected by the operator. A program is stored at a memory location (e.g. 'M01') and contains one or several seams (max. number is six). The selected program and the assigned seams are imaged in the upper line of the display. The machine executes all enabled seams of a program sequentially. An enabled seam is displayed inverted. You can produce several pocket shapes and lengths sequentially, without changing the sewing program.

4.2.2.1 Select a sewing program

The current sewing program is displayed in the upper line of the display. How to select a program:

1. Press M/C-key.
2. Enter the number of the desired program using the ten key pad.
3. Press ENT-key.

4.2.2.2 Enable/disable seams

Seams are assigned to every sewing program. All enabled seams are sewed sequentially. Enabled seams are displayed inverted.

If a seams shall be skipped, it must be disabled. How to enable/disable a seam:

1. Move the cursor on the desired seam using the arrow keys.
2. Press the ENT-key to enable/disable the seam.

4.2.2.3 Change seam length

Several parameters of the current seam are imaged in the left half of the display (e.g. seam length, center knife position). You can change these settings individually using the function keys. All changes executed with the function keys are stored for all seams with the same number, even if they are used in different programs.

Further information are contained in the chapter '4.1.1.3 Function keys'.

4.2.2.4 Remove and add seams

● Remove seams

1. Select the sewing program to be changed.
2. Press the P-key.
3. Press F1.
4. Move the cursor on the seam to be removed using the arrow keys.
5. Press the M/C-key.
6. Repeat steps 4. and 5. for all seams to be removed.

- **Add seams**

1. Select the sewing program to be changed.
2. Press the P-key.
3. Press F1.
4. Use the arrow keys to move the cursor to the place, where you want to add a seam.
5. Press the ENT-key.
6. Enter the number of the desired seam.
7. Repeat steps 4. to 6. for all seams to be added to the current sewing program.
8. Press the P-key to store the settings and leave the submenu.

5 Required cleanings



To achieve the value and function of the machine, we recommend to keep it always clean and free of spare materials and waste.

Blow off threads and cloth rests daily from the machine using the air pistol.

Part 2 Mechanics manual



Hint

This part of the operating instructions contains all information required to put the machine into operation and to do programming, troubleshooting and maintenance. It addresses to trained technical personnel, which is able to overview their tasks and recognize possible danger at an early moment.

Contents

Page

Part 2 Mechanics manual

1	Diagram of the menu structure	15
2	Programming instructions	16
	2.1 Create new sewing programs (P-F1)	16
	2.2 Seam functions (P-F2)	16
	2.3 Seam parameters(mechanical moving and speed control)	17
	2.4 Basic parameters	18
	2.5 Other Functions P-F6.....	18
3	Circuit	20
4	Trouble Shooting.....	202

1 Diagram of the menu structure

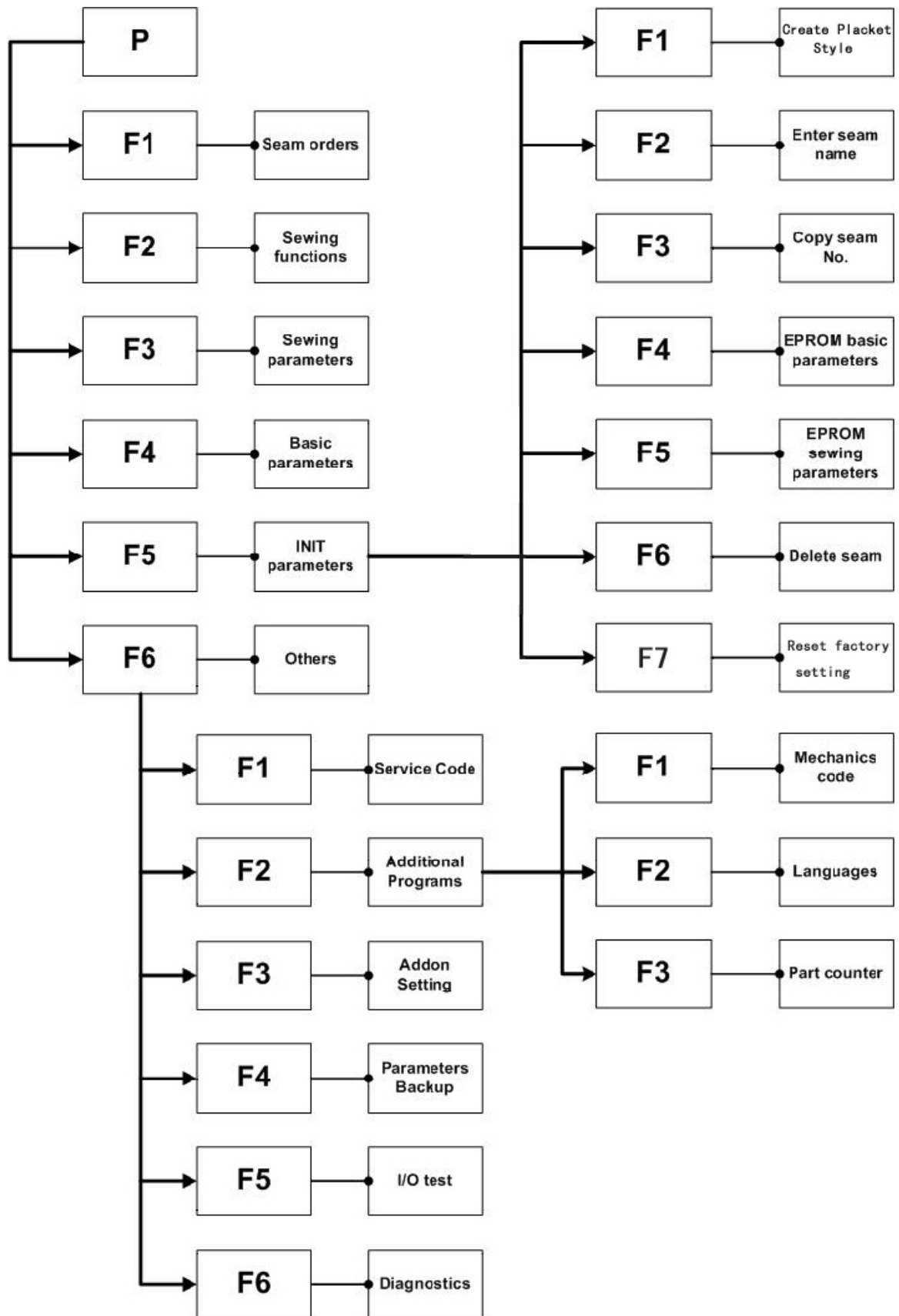

2 Programming instructions

2.1 Create new sewing programs (P-F1)

● Add seams















1. Use the arrow keys to move the flashing cursor to the seam you want to add, press ENT;
2. Use the ten key pad to input the code number for this seam, it should be 2 digit, press Aent;
3. Move the flashing cursor to continue to add other seams.

Finishing above operations, press P to the Main display, you can find the new added seam.

● Delete seams

1. Use the arrow keys to move the flashing cursor to the seam you want to delete, press M/C;
2. Move the flashing cursor to continue to delete other seams.

2.2 Seam functions (P-F2)

Picture	Name	Function
	Center knife	cuts the placket between the seams
	Stacker	stacks the sewed parts automatically
	Seam backtacking	Tack length at seam start and seam end
	Stitch condensing	Stitch length at seam start and seam end, the stitch is smaller than normal
	Ladies style	Ladies style
	Gent's style	Gent's style
	Polo	The stitch length of left and right is same, used for POLO style.
	Other style	Left and right stitch can be slanted, used for other polo
	U style	The stitch is U shape
	V style	The stitch is V shape
	Vignette	The stitch is rectangle
	Left T style	The stitch is Left trapezia shape
	Right T style	The stitch is Right trapezia shape
	Grid&Strip	Assistant setting

2.4 Basic parameters

The basic parameters contain the general settings of the machine.

Attention: As a factory setting, the basic parameters are optimized. Improper changes may cause faults in the machine process, which may lead to a reduction of quality and damages to the machine.

Follow this procedure to changes basic parameters:

1. Press the P-key.
2. Press F4.
3. Select the desired basic parameter using the arrow keys. Press ENT-key.
4. Enter the desired value.

Repeat steps 3. to 5. for all desired basic parameters.

Press the P-key or Back-key to leave the submenu.

Sq. No.	name	parameter	Definition
1	Thread length full spool	57mm	Length of bobbin
2	Clamp down time	0s	bak
3	time after clamp down	0.1s	bak
4	clamp back time	0.2s	bak
5	center knife down time	0.3s	bak
6	Clamp up time	0.2s	bak
7	Fabric picking time	0.8s	Stacker pick up work time
8	Feeding roller time	0.3s	bak
9	Clamp moving speed	80%	Clamp moving speed from back to front
10	Process step-by-step	OFF: one pedal one action, ON: one pedal two action	
11	Thread trimmer speed	250RPM	Hosing setting
12	Thread trimmer position	150	Hosing setting
13	Thread trimmer time	0.02s	Hosing setting

2.5 Other Functions P-F6

- **P-F6-F1: Input service code (AAAAAA)**

Press “F1” and press “1” for six times continuously at the same time, and then press “ENT”.

Note: Other menu and related functions of P-F6 can only be performed after the input of service code. This function is for maintenance application.

- **P-F6-F2: Additional programs**

F1: Mechanics code

F2: Languages: Chinese/English

F3: Part counter: The number of total work piece is showed

- **P-F6-F5: I/O test**

All inputs with their numbers will be displayed in the upper half of the display. The inputs displayed inverted are currently active. All outputs with their numbers are displayed in the lower half of the display. The outputs displayed inverted are currently active.

You can now select an output using the arrow keys and activate or deactivate it by pressing the ENT-key. If you press the ENT-key longer than two seconds, the output switches between active and de-active, until you press the ENT-key again (shortly).

The following inputs and outputs are available in this machine.

Input	Description	Sensor No.	function
02	Right clamp width sensor	02	Check the mechanic position of right clamp
03	Left clamp width sensor	03	Check the mechanic position of left clamp
04	Machine head center positioning sensor	04	Set the center position of machine head
05	Machine head original point sensor	05	Set the back position of machine head
06	Center knife position sensor	06	Check center knife up or down
07	Clamp back position sensor	07	Check the clamp on back position or not
08	Clamp front position sensor	08	Check the clamp on front position or not
12	Sensor of Needle away off plate	19	Check the clamp feeding position
17	Thread broken sensor	17	Check the needle thread broken
20	Needle up position sensor	20	Check the needle up position

output	Description	Valve No.	function
01	Main clamp left cylinder	01	Control the left clamp up or down
02	Stacker long cylinder	02	Control the action of the stacker long cylinder
03	Stacker short cylinder	03	Control the action of the stacker short cylinder
04	Fabric picking cylinder	04	Control the stacker pick the fabric
05	Air blow joint	05	Control the air blow
06	Center knife cylinder	06	Control the center knife up and down
07	Small clamp cylinder	07	Control the small clamp up and down
08	Center knife actuator	08	Control the center knife moving stroke
15	Grid&Strip cylinder	15	Control the Grid&Strip up and down
16	Main clamp right cylinder	16	Control the right clamp up and down

3 CIRCUIT



- A: Control Board
- B: Fuse
- C: Power Board
- D: X-Shaft Motor Driver
- E: Y-Shaft Motor Driver

3.1 Control Board

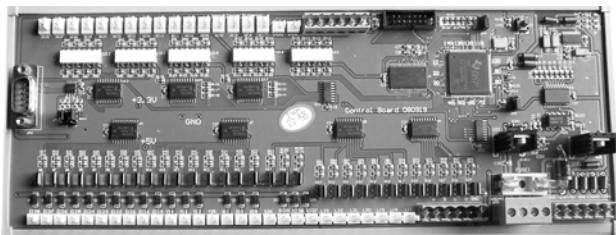

- Sensor connector, on the up part of the control board, with 16 ports which are numbered from SE01 to SE20 on the board. A number pipe is installed on the connection of each sensor accordingly.
- Solenoid controlled connector, on the down part of the control board, with 13 ports which are numbered from EC01 to EC28 on the board. A number pipe is installed on the connection of each solenoid controlled connector.
- Motor controlled connector, on the down part of the control board, with 6ports which are numbered from X9 to X11 and Y12 to Y14 on the board. A number pipe is installed on the connection of each solenoid controlled connector.
- Laser light connector, on the down part of the control board, with 7 ports which are numbered from L17 to L23 on the board. A number pipe is installed on the connection of each laser light.
- Communication connector, on the left part of the control board, is the communication connector between the liquid crystal box and the board and applied to offer voltage and signal to the liquid crystal box.
- Power source indication lamp, on the up right part of the control board, two couples of them would be on when the current is switched on, which stand for +5V and +3.3V separately.

3.2 Fuse

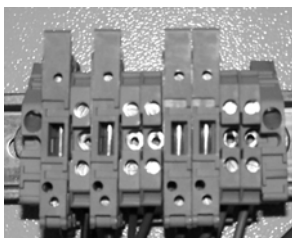

Fuse type and Location: When fuse fuesd, find out the cause and fix it before replace the new one.

CAUTION: Turn off the power and wait 10 minutes before opening box cover.

3.3 Power Board



The function of power board is to convert the alternating current output by the transformer into direct current.

Transformer: AC 220V ~ DC 24V

3.4 X-Shaft Motor Driver

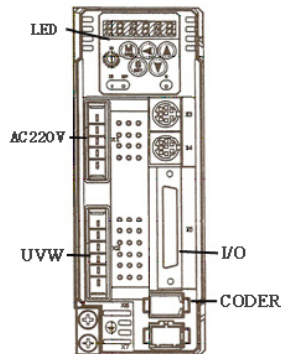

Status indicators(LED) indicate operating states and any malfunctions.

3.5 Y-Shaft Motor Driver

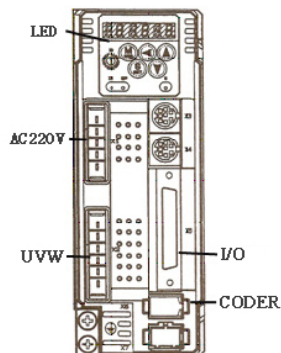

Status indicators(LED) indicate operating states and any malfunctions.

3.6 Adjust intensity

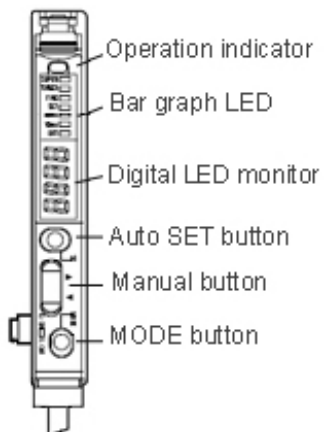

With no target in place, press the SET button and release it. The orange LED lights. Position a target in place. Press the SET button again and release it.

4 TROUBLESHOOTING

Error message	Circumstances	Recommended actions
Error 01: Sewing program empty	current sewing program is empty, possibly distances and values are not entered or the whole program is deleted	enter program values manually if required; copy from other programs or load from the memory (INIT parameter)
Error 02: Seam not enabled	current seam not enabled;	Press ENT-key to enable the seam
Error 03: machine head original position mistake	Machine head original position sensor not fixed correctly	1. check the sensor of ES05 2. check motor driving cable 3. check driving mistake report
Error 04: machine head center position mistake	Machine head center position sensor not fixed correctly	1. check the sensor of ES04 2. check motor driving cable 3. check driving mistake report
Error06/Error07: parameter setting mistake	Parameter setting not fixed to the pattern	Adjust the setting
Error 08: Main clamp at the stop	limitation switch SE08 switched during clamp move, although the clamp is at a distance	check distance counter using the test program ; if counter defective, change clamp engine, if counter ok, check both switches and connections
Error 09: clamp can not leave the back position	Back positioning mistake	1. check the back position sensor SE07 2. check motor driving report
Error 10: Collision between machine head and pressure foot	The movement distance of machine head, which set up based on the knife as central point is bigger than the real distance of sewing process	Please adjust the location of left and right pressure foot to the knife according to parameter, otherwise will break the machine seriously.
Error 21: Center knife not up	Center knife couldn't reach top position within error time	check cylinder , termination switch SE06
Error 34: Needle not up	needle couldn't reach the top position; with the error message the control tries to put the needle into the top position again	1、 press ENT to return 2、 check signal wire for upper position
Error 35: Thread broken	thread monitor detects breakage	adjust the tension of thread; get rid of the burrs
Error 36: Spool empty	mode 'Bottom thread counter' enabled; remaining length is zero	change bobbin thread; reset the length of bobbin thread
Error 45: communication mistake	Communication cable loose	1. check the cable connection 2. check the power indicator
Error 127:	service code not input	press P-F6-F1 and input service code (AAAAAA)
Operation stopped	Touch the back pedal during operation	Touch the forward pedal to recover