

# SIRUBA

使用說明書與零件圖

INSTRUCTIONS BOOK & PARTS LIST

■ S007K/S007KD

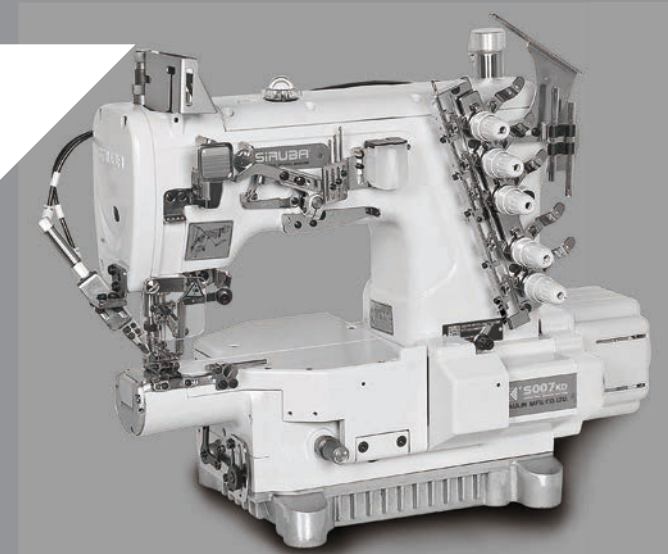
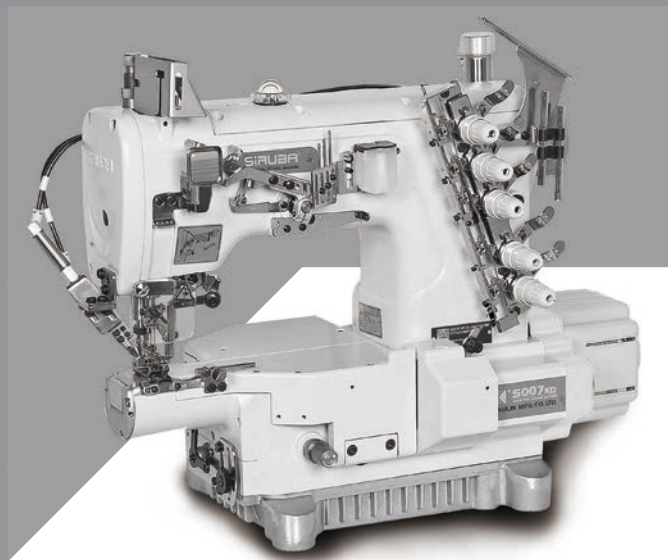

 高林股份有限公司  
KAULIN MFG. CO., LTD.

由於對產品的改良及更新，本產品使用說明書中之產品及外觀的修改恕不事先通知！  
The specification and/or the equipment and appearances described in the instruction book are subject to change because of modification which will without previous notice.  
SY201K.JAN.2021





本使用說明書內容適用於以下機型：

The content of this instruction book is for the models:

**S007K 2<sup>nd</sup> GENERATION ERIES/S007KD 2<sup>nd</sup> GENERATION**





### 危險水準的說明

#### Explanation of Dangerous Level

 危險 Dangerous	如果忽視此標記而運行了錯誤的機械操作, 保養時肯定會引起當事者或第三者人員重傷或死亡 Don't ignore the warning sign and don't proceed incorrect operation. Or it will cause the person or the third party seriously injured or dead during maintenance.
 注意 Caution	如果忽視此標記而運行了錯誤的機械操作, 保養時有可能會引起當事者或第三者人員受傷及造成設備損壞 Ignoring this warning sign and proceed incorrect operation will cause the person involved or the third party wounded and equipment damaged during maintenance.

### 警告圖案表示及表示標誌的說明

#### Explanation of Warning Signs and Labels

警告圖案表示 Warning Sign		運動部位, 謹防工傷事故 Moving part, beware of industrial accident
		高壓部位, 謹防觸電事故 High voltage, beware of electric shock
		高溫部位, 謹防燙傷事故 High temperature, beware of burns
指示標幟 Instruction Label		禁止 Prohibited
		地線的接線表示 Indication of ground wiring

索引	INDEX	頁/PAGE
一般安全事項說明	GENERAL SAFETY INSTRUCTIONS	1
重要安全事項說明	IMPORTANT SAFETY INSTRUCTIONS	3
特別事項	WARNING	7
警告標籤	WARNING TAG	8
護針安全圖說	SAFETY ILLUSTRATION OF THE NEEDLE GUARD	9
搬運縫紉機	MOVING THE SEWING MACHINE	9
縫紉機的安裝位置	THE INSTALLATION POSITION	10
規格	SPECIFICATIONS	10
各部件名稱	NAMES OF MAJOR PARTS	14
關於本機的重要安全事項	IMPORTANT SAFETY INSTRUCTIONS OF THIS MACHINE	15
安裝	INSTALLATION	16
馬達之安裝方式	INSTALL THE MOTOR	18
馬達與皮帶	MOTOR AND BELT	19
穿線方法	HOW TO THREAD	19
線鬆緊度調整	ADJUST THE THREAD TENSION	20
針線挑線桿調整	ADJUST THE NEEDLE THREAD TAKE-UP	20
上叉線挑線桿調整	ADJUST THE SPREADER THREAD TAKE-UP	21
押具調整	ADJUST THE PRESSER FOOT	22
押具壓力調整	ADJUST THE PRESSER FOOT PRESSURE	22
縫目長度調整	ADJUST THE STITCH LENGTH	23
差動比調整	ADJUST THE DIFFERENTIAL RATIO	23
潤滑	LUBRICATION	24
潤滑油之注入與更換	LUBRICATION AND DRAINAGE	25
操作環境照明	LITENING OF THE OPERATION ENVIRONMENT	26
操作者條件	CONDITIONS OF ALL OPERATORS	27
針與線之冷卻與潤滑	LUBRICATE AND COOLING OF NEEDLE AND THREADS	27
保養	MAINTENANCE	28

索引	INDEX	頁/PAGE
針之更換	REPLACE THE NEEDLES	29
結束密縫調整	ADJUSTING THE PRESSURE OF PRESSER FOOT	31
故障檢修	TROUBLESHOOTING	31
桌板圖	TABLE CUT-OUT	42
零件圖	PARTS LIST	46
報廢流程	DEMOLITION PROCEDURE	72

MODEL		S007K/S007KD	
Net Weight(Kg)	44.5	Noise Level, dB (A)	80 dB (A)
Dimension	Length	Width	Height
	40/45 cm	30 cm	42 cm

## 一般安全事項說明

### 警告！

當使用這台機器，基本安全預防應恆被遵守，以減輕火災、電擊、或是個人傷害的風險。包含以下注意事項。在操作這台機器之前，請閱讀所有說明並且謹記於心。

- 1. 保持工作場所清潔**  
雜亂的環境與椅子會招引危害。
- 2. 考量工作場所環境**  
勿暴露電源於雨水之中、勿在濕氣重的地方或潮濕的場所使用機械器具。保持工作場所良好整齊。當有引發火災或爆炸危險時，勿使用電源工具。
- 3. 免於電擊危害**  
避免身體接觸地線或是接地表面。(即：管線，發熱物體，以及冷凍庫)
- 4. 勿使孩童接近**  
不要讓訪客碰觸工具或是延伸管線
- 5. 適當的穿著**  
不要穿著寬鬆衣物或穿戴珠寶，這可能被活動零件拉扯而導致危險。穿戴護髮套以包含住長髮。
- 6. 不要任意拉扯電線**  
絕不要用電線端拉扯機器，或是從插座猛拉電線來拔掉電線。使電線遠離熱源、油類或是尖銳邊緣。
- 7. 謹慎保養機器**  
遵從指示來添加潤滑油或是更換附件。定期檢測工具用線，如果有所損害，請使用合格的維修器具來修復。

## GENERAL SAFETY INSTRUCTIONS

### Warning!

When using this machine, basic safety precautions should always be followed to reduce the risk of fire, electric shock and personal injury, including the followings. Read all these instructions before operating this product and save these instructions.

- 1. Keep work area clean**  
Cluttered areas and benches invite injuries.
- 2. Consider work area environment**  
Do not expose power to rain. Do not use machine tools in damp or wet locations. Keep work area well lit.  
Do not use power tools where there is risk to cause any fire or explosion.
- 3. Guard against electric shock**  
Avoid body contact with earthed or grounded surfaces (e.g. Pipes, radiators, ranges refrigerators.)
- 4. Keep children away**  
Do not let visitors touch the tool or extension code.
- 5. Dress properly**  
Do not wear loose clothing or jewelry, they can be caught in moving parts. Wear protecting hair covering to contain long hair.
- 6. Do not abuse the cord**  
Never carry the machine by cord or yank it to disconnect it from the socket. Keep the cord away from heat, oil, and sharp edges.
- 7. Maintain machine with care**  
Follow instructions for lubrication and changing accessories. Inspect tool cord periodically. If damaged, have it repaired by an authorized service facility.

8. **分開機器**  
當不使用機器時、維修前、以及更換配件時。
9. **避免誤啟動**  
不要以手指置於啟動開關上之後，搬運一個已插入電源的工具。確定在插電之前，電源開關是關閉的。
10. **檢查損害零件**  
在進一步使用器具之前，應該小心檢查並確認損傷的零件或是穿戴保護器具來確認零件會正確運轉並且呈現應有功能。
11. **警告**  
除了在這本使用說明手冊中建議的功能之外，任何附件或是配件的使用，都可能會導致個人傷害的危險。
12. **由合格人員來修理事具**  
所以的修理工作應該由合格的人員使用原始個別零件來作修理。

### 連接電源的特別警示

1. 只可與有"CE"認證的按壓啟動裝置連接這台機器。
2. 遵守此使用說明手冊來安裝控制裝置。
3. 在操作過程中，永遠保持機器適當的接地。
4. 在調整、更換零件、或是維修保養之前，必須確定將插頭由插座拔出，以預防任何機器意料之外的啟動而造成危害。







8. **Disconnect machine**  
When not in use, before servicing and when changing accessories.
9. **Avoid unintentional starting**  
Do not carry a plug-in tool with a finger on the switch. Ensure the power switch is off when plugging in.
10. **Check damaged parts**  
Before further use of the tool, a guard or other part that is damaged should be carefully checked to determine that it will operate properly and perform its intended function.
11. **Warning**  
The use of any accessory or attachment, other than those recommended in this instruction manual, may present a risk of personal injury.
12. **Have your tool repaired by a qualified person**  
Repairs should only be carried out by qualified persons using original spare parts.

### **SPECIAL WARNING FOR ELECTRIC CONNECTION!**

1. Incorporate this machine only with "CE" certificate hold-to-run control device.
2. Follow the instruction manual device to install control device.
3. Always earth machine appropriately during operation.
4. Before adjustment, parts change or servicing must be sure to pull out the plug from socket to prevent the hazard of unintentionally start of machine.







### 重要安全事項說明

恭喜您購買本機器, 為了使這台機器能獲得最佳功能以及安全的操作, 務必請正確的使用這台機器, 使用前請仔細閱讀使用說明書, 希望您能長期使用它。請記得將此說明書放在容易取得的地方。

-  1. 當您使用機器時, 除了以下事項外, 請注意其他基本安全措施。
-  2. 使用機器前, 除了這本使用說明書外, 請詳細閱讀其他有關說明書。此外, 請妥為保存這本使用說明書, 以便需要時可以隨時取閱。
-  3. 先確認機器是符合貴國安全規定及標準後, 再使用機器。
-  4. 當機器完成操作準備時, 所有安全配備必需安裝就緒, 在缺少所述安全配備下操作是不被允許的, 以免導致人員受傷。
-  5. 此機器應由受過適當訓練之操作員操作。
-  6. 為了安全, 我們建議您配戴安全眼鏡。
-  7. 以下情形, 請先關閉電源或拔掉插頭:
  - (1) 穿針線、線導片、天平等以及更換梭子時,
  - (2) 更換針、押具、針板、送具、頂針片、喇叭、車布導板, 以及其他附屬配件時。

### IMPORTANT SAFETY INSTRUCTIONS

For operating safely and getting the best functions of this machine, you must operate it correctly. Please read and follow the instructions of this manual, and keep it at hand for future references. We are confident that you will enjoy this machine as much as we enjoy manufacturing it.

-  1. Instead of the following instructions, when you use this machine, please pay attention to the basic safety measures.
-  2. Before using this machine, please read this manual and all related instructions. In addition, please keep this manual for future needs.
-  3. Before using this machine, please ascertain that it conforms with safety standards and regulations of your country.
-  4. When the machine is ready for operation, all the safety equipments must be ready. Operate this machine without the specified safety devices is not allowed.
-  5. This machine must be operated by a properly trained operator.
-  6. For your own safety, we suggest you wearing goggles.
-  7. Please turn off the power switch or disconnect it for any one of the circumstances of the followings :
  - (1) When threading needle(s), adjusting thread Take-up(s), thread guide(s), and / or replacing bobbin(s),
  - (2) When replacing needles, presser feet, needle plates, feed dogs, needle guards, horns, cloth guides and other parts or accessories.





- (3) 維修工作時。
- (4) 離開工作場所或工作場所無人看顧時。
- (5) 若使用離合器馬達而無煞車片裝置時，必需待馬達完全停止。

- (3) When repairing,
- (4) When the operator leaves the working place or leaves the machine unattended.
- (5) If clutch motors without brake pads are used, must wait until the motor stops completely.

 8. 假如不慎讓機器及配件使用之油或油脂，接觸到眼睛、皮膚或誤食時，請立刻以水清洗接觸部位及就診。

 8. If grease, oil, or any fluid contacts your skin or eyes by any chance, please wash the contacted area completely with clean water and consult a doctor. Or, swallow any fluid mistakenly, consult a doctor immediately.

 9. 請勿擅自碰觸運轉中之零件及配件及注意機器電源是否已開啟，以免導致人員受傷。

 9. Do not touch any functioning parts and devices. Always attend to whether power switch is on or off before operating in order to prevent anyone from getting hurts.

 10. 維修、修改及調整等工作，需由受過適當訓練的技師或熟手為之。維修時只許使用指定之零件。

 10. Qualified technicians are required for adjustment, modification, and repair. Only use assigned parts for replacement.

 11. 一般維修及檢查工作必須由受過適當訓練的人員為之。

 11. Routine maintenance and service must be performed by well trained persons, or qualified technicians.

 12. 電子零件維修及保養工作必須由資深的電子技師為之，或由非常熟練的人員檢查及指導，當發現零件損壞時，請立刻停止機器運轉。

 12. Maintain and check the electronic parts must be done by qualified electrician or well-trained persons. If any electronic part damaged or malfunctioned, stop the machine immediately.

 13. 在做裝有氣動式零件(例如氣缸)機器的維修及保養工作前，機器連接空壓機及高壓空氣必須予以關閉及卸除，機器中殘存高壓氣體必需予以消除，此外調整及性能檢查只能由受過適當訓練的技師或熟手為之。

 13. The air hose has to be detached from the machine and the compressor or air supply has to be cut off before repairing and servicing the machine equipped with pneumatic parts such as an air cylinder. Qualified technicians or well-trained persons are required for adjustment and repairs.

 14. 機器使用一段時間，必需定期清理。

 14. To ensure the best performance, periodically clean the machine is necessary.

 15. 為使機器能正常操作及減少噪音，機台務必平放地上，機器避免在強烈噪音的環境下操作。

 15. In order to operate properly and to reduce the noise, please place the machine flat and level on the ground. Avoid operating the sewing machine at a noisy surrounding.

 16. 選用適當的電源插頭，並由電子技師將其按裝在機器上，且插頭必需插在接地線之插座上。

 16. Select a proper power plug and install it by an electrician. Please connect the power plug to a grounded receptacle.

 17. 機器只允許被使用於指定用途上，其他用途是不允許的。

 17. This machine can only be used for the designed purpose. Other uses of this machine are not allowed.

 18. 修改或變更機器必需依照安全規定及標準，同時採取有效的安全措施，本公司不承擔任何私自因修改或變更機器所引起損壞之責。

 18. Any modification or conversion made on this machine must be conformed with the safety standards and regulations. Precaution is necessary. No responsibility will our company take for damages caused by any modification or conversion of this machine without permission.

19. 警告提示以兩種符號標示：

19. Two safety warning signs are applied as warning signs:

 (1) 對操作員或服務人員之傷害危險，也為了避免觸電之危險，請勿打開馬達電器箱之外蓋，也不要觸摸電器箱裡面之零件。

 (1) For the safety of operators and service persons, please don't open the cover of any electronic control boxes of motor or other devices and don't touch any components inside to avoid electrical shock hazards.

 (2) 必需特別注意事項

 (2) Always keep in mind :

a. 絕對不可在移開皮帶蓋，手指保護蓋或安全配件後，進行機器操作，以免導致人員受傷。

a. Please never operate this machine without belt cover, finger guard or any safety device to avoid physical injury.

 b. 為了避免被機器纏住，當機器運轉中，您的手、頭髮及衣服，需遠離手輪，皮帶及馬達；此外這些部位周圍不可放置任何物品，以免導致人員受傷。

 b. Please keep your hair, fingers and cloths away from the hand wheel, V belt and motor while the machine is in operation, as well as never put anything near these parts, to prevent the risk of injuries by tangled into them.



c. 當您打開電源開關後或機器已在運轉中，絕不可將您的手放在針的下方或針線控線桿外蓋中，以免導致人員受傷。



c. Please never put your fingers under the needle(s) or in the thread take-up cover to prevent physical injuries when you turn on the power switch or operate the machine.



d. 當機器運轉中，梭頭高速轉動，為了避免對手可能引起之傷害，必需確定您的手保持遠離梭頭附近。此外，當更換梭子時，確定電源開關已關閉，以免導致人員受傷。



d. While the machine is in operation, the hook rotates at a high speed. Please keep your hands away from the area of hook to prevent any potential injury to your hands. In addition, please make sure to turn off the power of the machine while changing bobbins.



e. 當放置或抬起機頭時，小心勿將手置於機器中，以免導致人員受傷。



e. Be careful and do not place your fingers inside the machine when placing or lifting the machine head to avoid possible physical injuries.



f. 為了避免機器突然啟動而引起可能意外，當機頭傾斜或移開皮帶蓋及皮帶時，請關掉機器電源，以免導致人員受傷。



f. Please turn off the power before tilting the machine head or removing the belt cover and the V belt to avoid possible accidents due to abrupt start of this machine.



g. 如果您的機器是配置伺服馬達，機器於靜止狀態時，馬達是不會產生噪音的，為了避免機器突然啟動而引起可能意外，故請關掉機器電源。



g. For machines equipped servo motors, the motors do not produce noise while the machines are at rest. Therefore, please turn off the power of this machine to avoid possible accidents due to abrupt start of the machine.



h. 為了避免觸電之危險，請絕不要在移開電源接地線後操作機器。



h. Never operate the sewing machine after the ground wire is removed to avoid electrical shock hazards.



i. 為了避免觸電或電子零件損壞而引起之可能意外，請先切斷電源，再插上或拔掉插頭。



i. Please turn the power switch off before connecting or disconnecting the power plug to prevent possible accidents due to electric shock or damaged electronic components.

## 特別事項

## WARNING

為了避免機器故障及損壞，請先確定以下事項：



1. 當您安裝好機器後，做第一次機器操作前，請徹底清潔機器。



Please confirm the followings to avoid malfunction or damage to this machine.

1. After installing the machine, and before the first operation, please clean it completely.



2. 清除運送途中累積之灰塵及溢出之油脂。



2. Clean all dust and overflowed oil during transportation.



3. 確定電壓及馬達相數(單相或三相)安裝正確。



3. Confirm that the voltage and the phase (single or 3 phase) of motor are set correctly.



4. 確定電源插頭正確地接上電源。



4. Confirm that the power plug is correctly connected to the power supply.



5. 當使用電壓與標示電壓不同時，請勿使用機器。



5. Never use the machine when the local voltage type is different from the marked voltage on the nametag attached on the machine.



6. 確定機器轉動方向是否正確。



6. Confirm that the rotating direction of the machine pulley is correct.



警告：  
在操作或調整本書中所提到之各步驟前，請先將電源關掉，以免因為機器突然啟動造成之意外。



Warning :  
Before doing any operation or any adjustment described later in this manual, please turn the power off to prevent accidents caused by abrupt start of the sewing machine.

## 警告標籤

- 縫紉機上有下列警告標籤。(圖1, 圖2)
- 當使用縫紉機時, 請遵守標籤上的說明。如果標籤脫落或模糊不清, 請和購買商店聯繫。



圖1/Fig. 1

- ③  必須接地

接駁地線不牢固, 是造成觸電或錯誤動作的的原因。

- ④  表示轉動方向

安全保護裝置(圖3)

- (A) 護指器  
(B) 護目鏡



圖3/Fig.3

## WARNING TAG

- The following warning tags will be attached on the sewing machine. (Fig. 1, Fig. 2)
- When using the sewing machine, please follow the instructions of the tags. Please contact the dealer if any of the tags is fallen off or fuzzy.



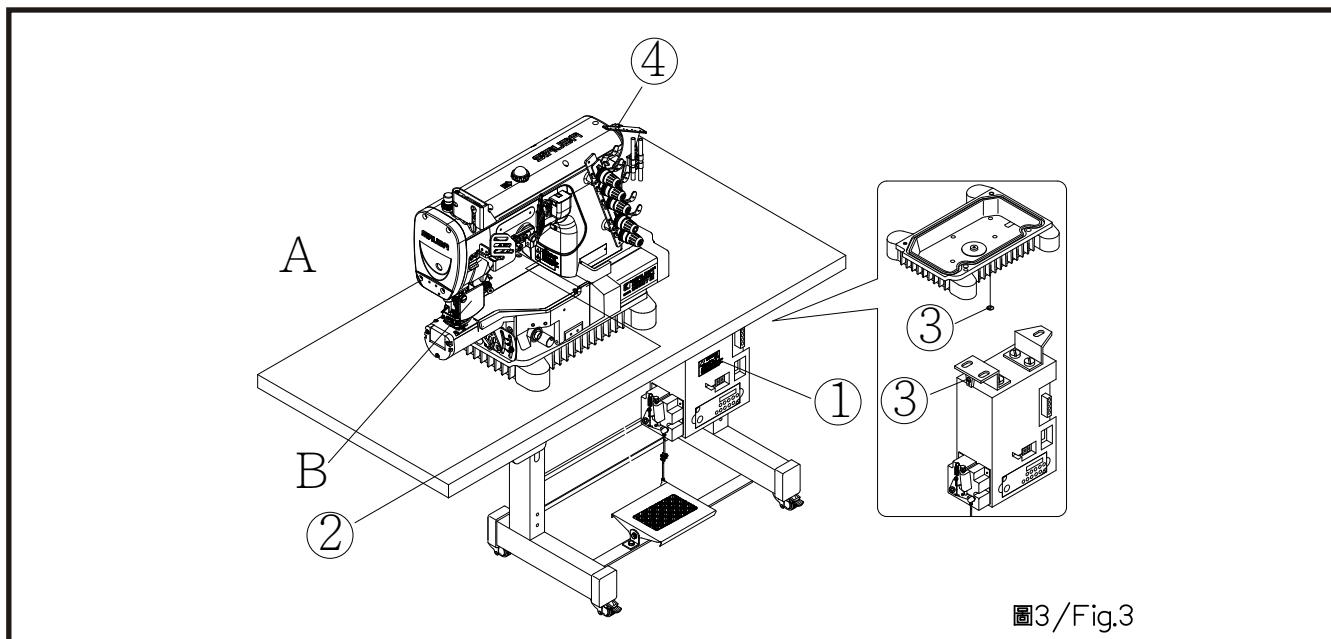

圖2/Fig. 2

- ③  Must have ground wire.

A loosen or a did not connect well ground wire is the reason causing electronic shock or malfunction.

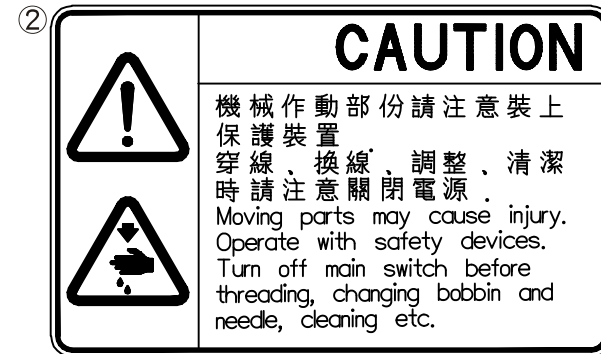
- ④  Indicates rotating direction.

Safety Protection Device (Fig. 3)

- (A) Finger Protector  
(B) Goggle

## 護針安全圖說

本縫紉機之押具防護裝置如圖所示, 為保護操作者的作業安全, 嚴禁將其裝置拆卸。(圖4)



圖4/Fig. 4

## SAFETY ILLUSTRATION OF THE NEEDLE GUARD

This presser foot protection device is as shown as the Fig. 10. For safety of all operators, this device shall not be disassembled. (Fig. 4)

## 搬運縫紉機

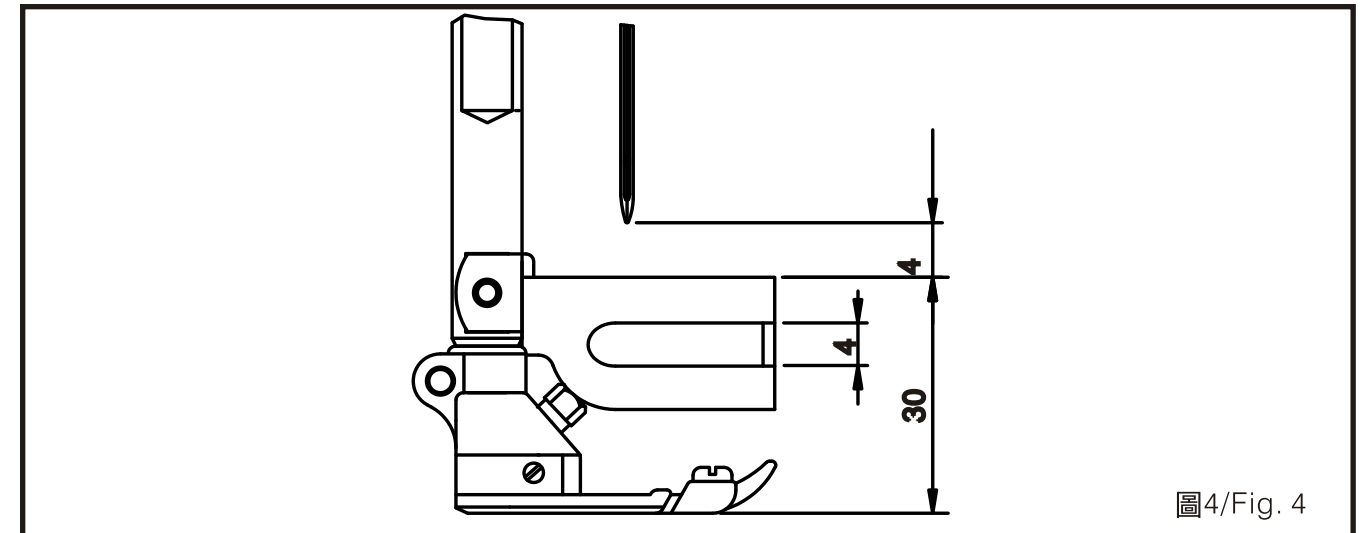
縫紉機之搬運(圖5)

1. 請由兩人用手托住機殼本體進行搬運。
2. 用手扶住馬達蓋(A)部, 使手輪不能轉動。
3. 搬運時, 請穿著安全鞋。

## MOVING THE SEWING MACHINE

Moving the sewing machine (Fig.5)

1. The machine should be carried by two people as shown in the figure.
2. Hold the motor cover (A) by hand, so that the pulley will not rotate.
3. Please wear a pair of skidproof shoes while moving the sewing machine.



圖5/Fig.5



## 縫紉機的安裝位置

## THE INSTALLATION POSITION

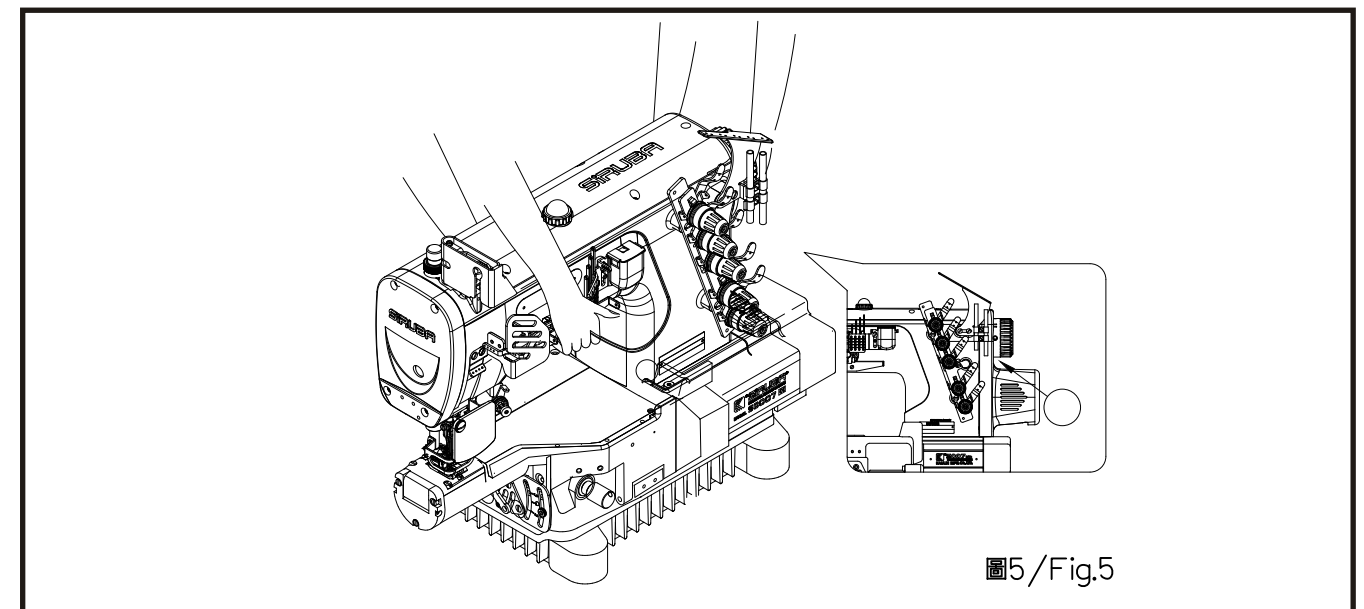
1. 勿將該縫紉機置於設備附近，如電視機、收音機或無線電話等，否則這些設備可能被縫紉機的電子干擾所影響。(圖6)
2. 應將縫紉機直接插入AC電源插座，如果使用延長線，可能會造成操作故障。

1. Please do not install the sewing machine near the equipments, such as Television, Radio, or Wireless Telephone. Or these equipments will experience electronic interference. (Fig. 6)
2. The wire should insert to the AC power socket directly. If using the extension wire, this might cause malfunction.

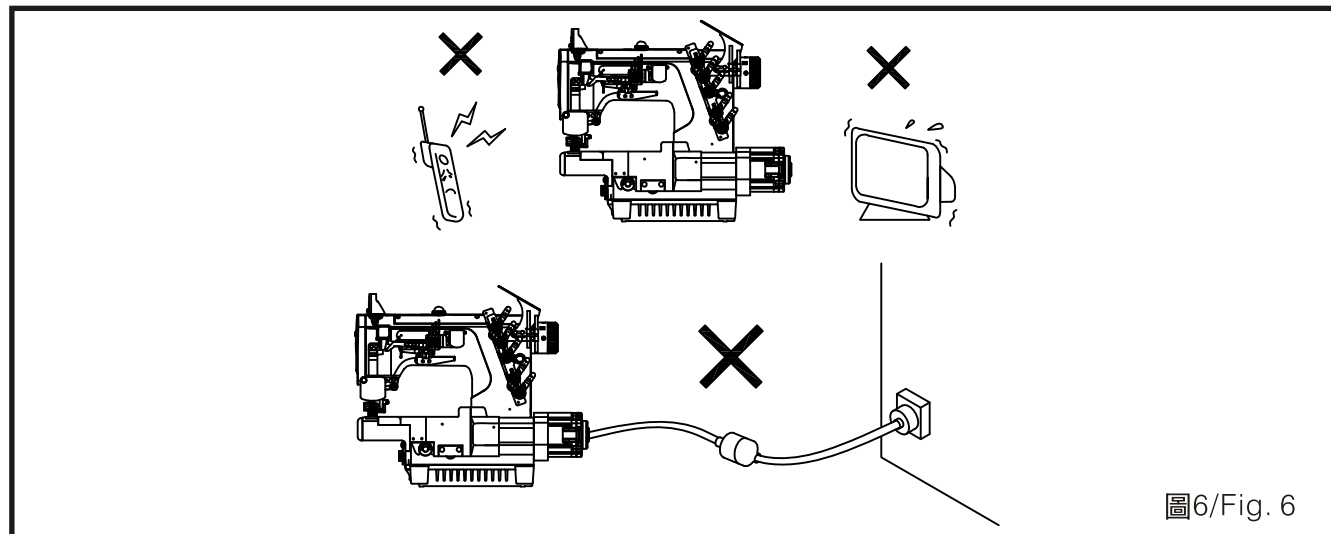

## 規格

## SPECIFICATIONS

### 種類及規格說明

### Specifications of machine category

#### 1. 型號及分類表示

#### 1. Description of the machine name

S007KD - W122 - 356/PCH-3M

① ② ③ ④ ⑤ ⑥ ⑦ ⑧ ⑨

①表示機種別：  
S= 環縫筒車

① represents the type of the machine:  
S = Small cylinder bed chainstitch machine

②表示車台外觀改良之區分編碼，由D然後E、F，以英文字母排列如S007K。

② represents the improved machine appearances that are arranged from letter F. Ex: S007K

③表示加裝伺服小馬達。

③ represents a small servo motor added.

④表示有無上叉縫

④ shows whether having upper cross stitchery or not.

W有上叉縫 (圖7)

W=have upper cross stitchery (Fig. 7)

U無上叉縫 (圖8)

U=without upper cross stitchery (Fig. 8)

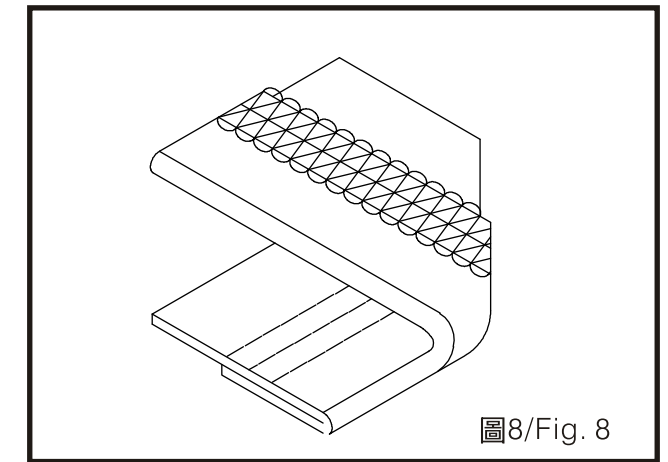
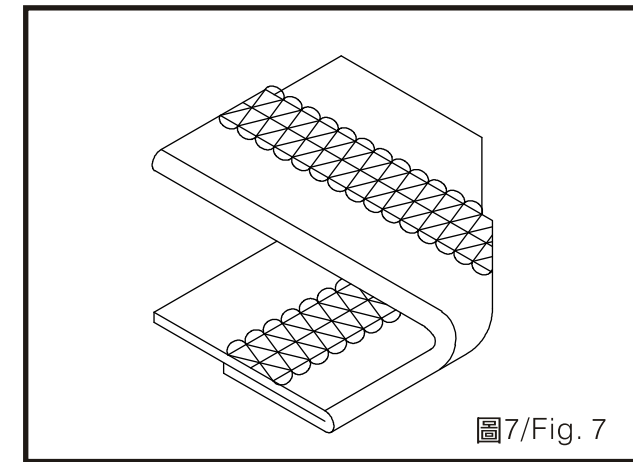

⑤車縫型式：

12= 一般平縫

32= 拷克骨車縫(包飾縫作業)

⑤ is stitching type:

12= normal & regular stitch

32= thread overlock seam covering (decorative stitching)

⑥表示針板舌片之形狀(針板舌的功能：打網)(圖9)

⑥ means the shape of the needle plate tongue, which its function is to knot. (Fig. 9)

1 為薄布用

1 = for thick/heavy materials

2 為中厚布用

2 = for midium- thick materials

3 為厚布用

3 = for thin/light materials

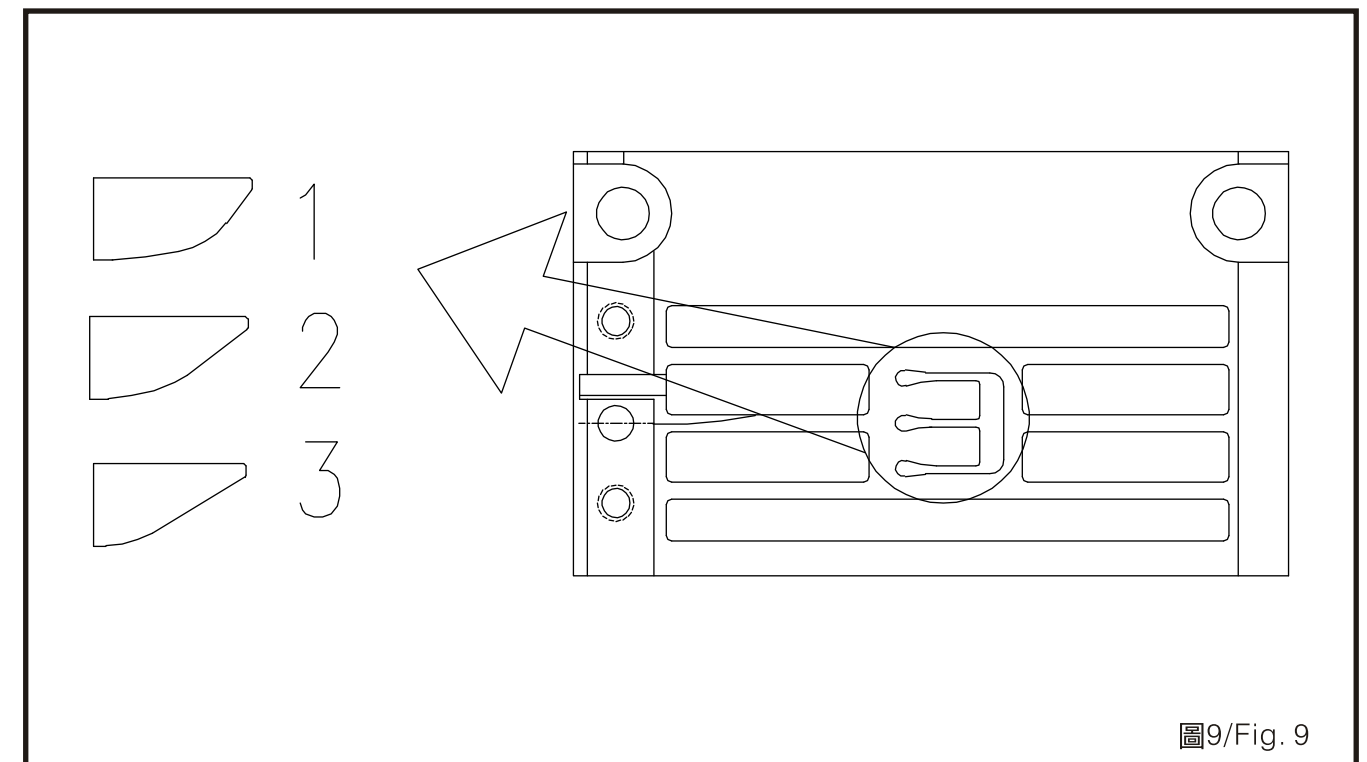

⑦表示針數 (圖10)

2為2針車

3為3針車

⑦ is the number of the needle. (Fig. 10)

2 = 2 needles sewing machine

3 = 3 needles sewing machine





圖10/ Fig. 10

⑧針寬(左右針之距離)(圖11)

⑧ means the needle width (the distance between the left and the right needle.) (Fig. 11)

2.4 mm, 4.8 mm

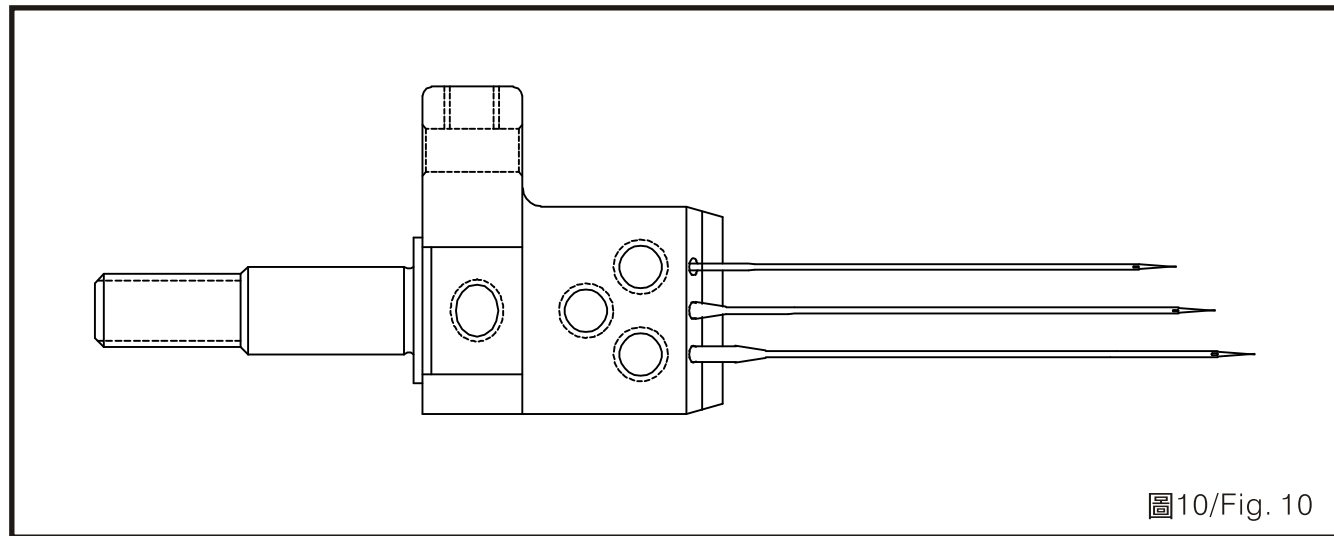
2.4 mm, 4.8 mm

3.2 mm, 5.6 mm

3.2 mm, 5.6 mm

4.0 mm, 6.4 mm

4.0 mm, 6.4 mm

⑨表示輔助件：如PCD、PCE、PCH等

⑨ indicates the accessories, such as PCD, PCE, and PCH.



圖11/ Fig. 11

2. 縫跡形式(圖表1)

2. Stitching format (Chart 1)

縫紉形式 Sewing Format	單層 Single Layer	雙層 Double Layer	平縫 Lockstitch	騎縫 Perforation	備註 NOTE 一般針織布 Normal Knitting Fabrics
	可 Yes	可 Yes	可 Yes	可 Yes	

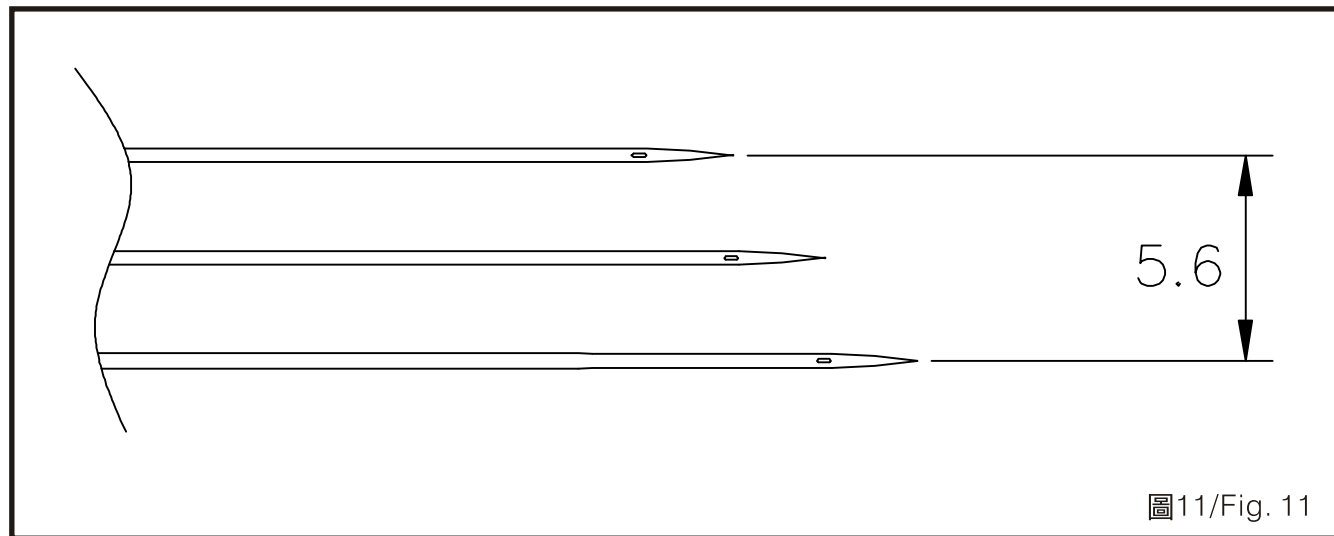
圖示說明Illustration				
縫紉模樣 Sewing Samples	布料 Fabric		圖示 Illustration	
	一般平縫 Normal Lockstitch	薄布料 Thin Fabrics	圖示 Illustration	騎縫 (過目縫) Perforation (Joint Junction Stitches)
	中厚布料 Medium Fabrics	圖示 Illustration		
	厚布料 Thick Fabrics	圖示 Illustration		

圖表1/Chart 1

3. 詳細規格說明(表1)

3. Detailed specification (Table 1)

規格Specification	機型別TYPES		
	S007K / S007KD-XX		
車縫布料Fabrics	薄布料 Light material	中厚布料 Medium weight material	厚布料 Heavy weight material
車縫速度(S.P.M.) Max. sewing speed	4500		
噪音Noise	80dB/4000 R.P.M		
針棒行程Needle bar stroke	31 ± 1 mm		
縫距Stitch length	2~3.6		
筒(嘴)型周長Diameter of the roll	181 mm		
大心扭力(kg-cm) Torsion of the main shaft	4		
震動值(N/S2)	1.0		
溫度(°C)	25		
差動比Differential ratio	0.8~1.4		
針上死點針尖與針板面距離 Needle tip to the needle plate at the upper dead point	7.6 ± 1 (mm)		
使用針Needle	UY128GAS 2/3/4		
押具壓力Presser foot pressure	4-5 KGF	5-7 KGF	
押具提升量Presser foot lifting height	手動 Lifting lever 5 mm		
押具Presser foot	可調整性押具Adjustable presser foot		
送料具高度Feed dog height	0.8 mm	1.0 mm	1.2 mm

規格Specification	機型別TYPES		
	S007K/S007KD-XX		
車縫布料Fabrics	薄布料 Light material	中厚布料 Medium weight material	厚布料 Heavy weight material
重量Weight	機頭/Head : 37.5 kg 控制箱/Control box : 4.1 kg 操作盒/Operation box : 0.6 kg		
桌板尺寸Bed specification	605 mm x 1200 mm/605 mm x 1070 mm		
加油方式Lubrication	完全自動加油 Automatic lubrication system		
潤滑油Oil	提供之自動油 SIRUBA sewing machine oil		
機頭驅動Machine head driving	直接驅動裝置Directly driving device/V型皮帶V belt		
馬達Motor	最大輸出/Max. output : 600W		
控制電路Control circuit	單相 Single-phase 220V ±15%		
使用電路Power	單相 Single-phase 220V ±15%		
電磁線圈驅動電源Solenoid driving power	氣動 : 24V 電動 : 30V		

表1/Table 1

## 各部件名稱

## NAMES OF MAJOR PARTS

- ① 過線盒
  - ② 導線片
  - ③ 押具
  - ④ 控制箱
  - ⑤ 油鏡
  - ⑥ 拉線鬆緊調整組
  - ⑦ 手輪
  - ⑧ 線架
  - 安全保護裝置
  - ⑨ 挑線桿防護罩
  - ⑩ 護指器
- 
- ① Thread guide box
  - ② Thread guide
  - ③ Presser foot
  - ④ Control box
  - ⑤ Oil window
  - ⑥ Thread tension adjusting set
  - ⑦ Pulley
  - ⑧ Thread stand
  - Safety Devices
  - ⑨ Thread take-up cover
  - ⑩ Finger guard



圖12/Fig. 12

## 關於本機的重要安全注意事項

## IMPORTANT SAFETY INSTRUCTIONS OF THIS MACHINE

1. 搬運作業
  - (1) 使用全罩二片式的保力龍將機器包裝防護。
  - (2) 放入紙箱內。
  - (3) 用手推車或二人用雙手抬動搬運。
2. 儲存作業
  - (1) 機器不使用時，應用防塵套將其罩上。
  - (2) 避免儲存於高於45°C以上的高溫。
3. 作業中
 

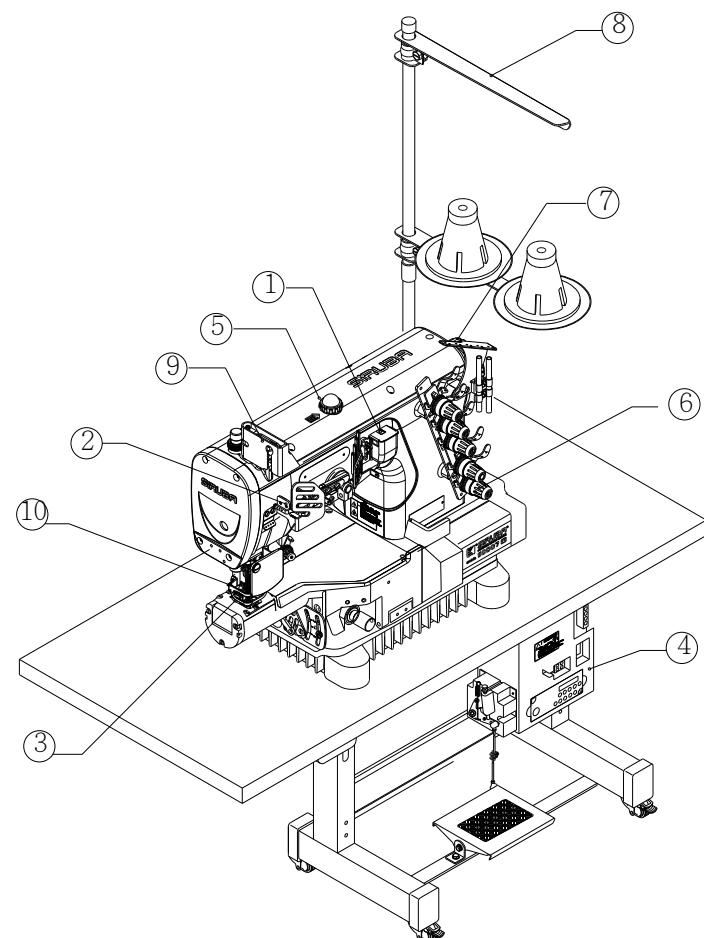
機器不要在高於40°C以上的溫度工作。
4. 警告
 

請注意以下警示建議事項。

- (1) 工作區域是危險的。
- (2) 當機器還在運作的時候絕對不要去碰觸針。
- (3) 當在送布料的時候要多加小心。
- (4) 不要把手指放在針與傳送布料的轉具之間。

在貼有警告標示之處請注意。

- (1) 機械動作部分，請注意裝上保護裝置。
- (2) 穿線、換線、調整、清潔時，請注意關閉電源。

1. Transportation
  - (1) The machine packed with two piece covers that made of expanded polystyrene to protect it.
  - (2) Put the machine into a carton.
  - (3) Use a cart or by two men's hands to move it.
2. Storage
  - (1) The machine must use duster cover to cover it when it did not work.
  - (2) The machine avoid to storage in the temperature more than 45°C.
3. Working
 

The machine doesn't work over 40°C.
4. Warning
 

Pay attention to this warning advice as the followings:





  - (1) Working area is dangerous.
  - (2) Never touch the needle if the machine is still running.
  - (3) Be careful if you infeed fabric.
  - (4) Do not insert your finger between needle and roller for transportation on fabric.

Pay attention to the warning sticker.

  - (1) Movable parts must be enclosed with guard when you operate.
  - (2) Pull out the plug from socket when you adjust, thread, change bobbin and needle clean.



注意CAUTION

-  請讓受過培訓的技術人員來安裝縫紉機。  
Machine installation should only be carried out by a qualified technician.
-  請委託購買商店電氣專業人員進行電氣配線。  
Contact your dealer or a qualified electrician for any electrical work that may need to be done.
-  縫紉機重37.5公斤, 安裝工作必須由兩人以上來完成。  
The sewing machine weighs 37.5 kg. The installation should be carried out by two or more people.
-  在安裝完成前, 請不要連接電源, 如果誤按啟動開關, 縫紉機動作會導致受傷。  
Do not connect the power cord until installation is complete. The machine may operate if the treadle is depressed by mistake, which could result in injury.
-  縫紉機頭倒下豎起時, 請用雙手進行操作。單手操作時因縫紉機的重量萬一滑落易導致受傷。  
Use both hands to hold the machine head when tilting it back or returning it to its original position. If only using one hand, the weight of the machine head may be too heavy to hold, and may cause human physical injuries.

1. 依本機器所附桌板裁製圖及零件組合圖所列之配件, 依序安裝防震機座線架。S007K/S007KD桌板使用T1或T2。
  2. 馬達之轉向為順時鐘方向, 皮帶之鬆緊度以用手指向內押下2 cm為宜, 同時為了安全起見, 請皮帶蓋必須鎖上。(圖13, 圖14)
1. Before installing this machine, please refer to attached table cut-out drawing, and parts lists. Then, install the anti-shock machine base and thread stand. S007K/S007KD use T1 or T2 table.
  2. The motor turning direction should be clockwise. In addition, the best motor belt tension is about 2 cm inward pressed by a finger. Meanwhile, for safety concern, please do lock the belt cover. (Fig. 13, Fig. 14)



圖13/Fig. 13



3. 皮帶輪與縫紉速度請照表2(一般機種適用)。
- 注意:
1. 使用新機器最初一個月運轉速度約為最高轉速之80%, 並請選擇正確的馬達皮帶輪尺寸。(如表2—一般機種適用)
  2. 桌板厚度約45mm。

3. For the correlation of the belt and the sewing speed, please refer to table 2 for more information. (For general type)
- NOTE:
1. During the first month of using new machine, the running speed shouldn't exceed 80% of the maximum speed listed in Table 2 (For general type). Please choose the correct size of the motor pulley.
  2. The standard thickness of the table is about 45 mm.

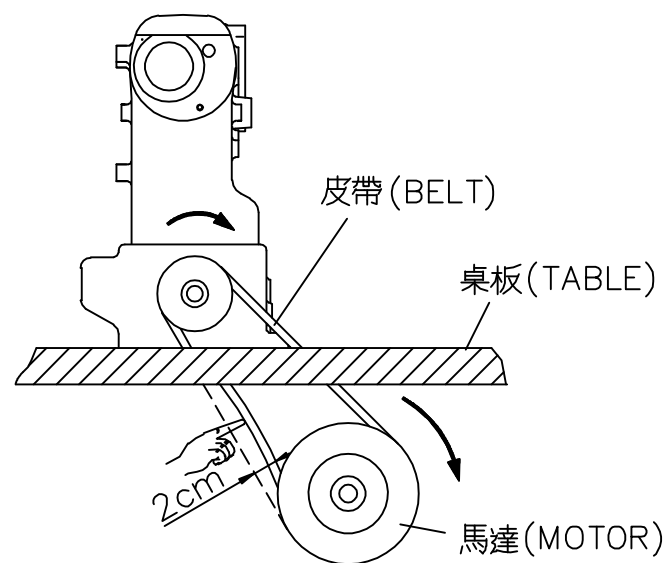
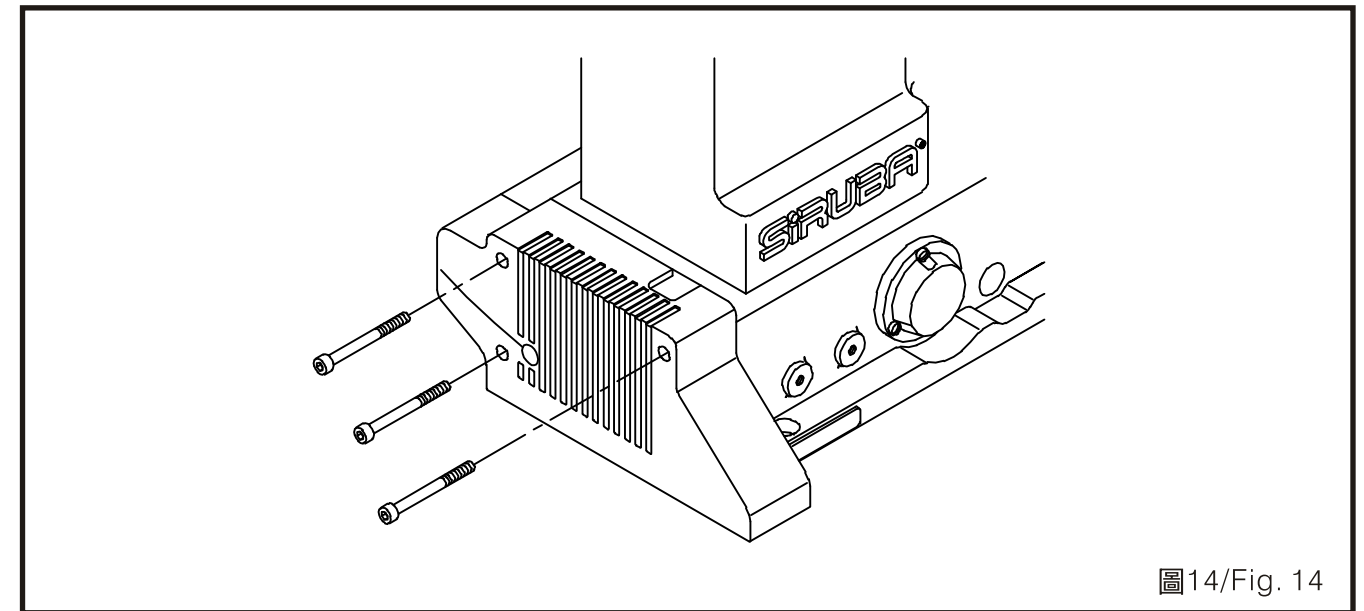
壓壓/壓 (S.P.M.)	Motor pulley Diameter(mm)		Motor belt V-belt, M-type (clutch motor)
	60Hz	50Hz	
6,000	105	125	36" ↑ 35" ↓ 34"
5,500	95	115	
5,000	85	105	
4,500	80	95	
4,000	70	85	

表2/Table 2

註：直驅伺服馬達額訂速度為5000 S.P.M但可做適度調整。  
P.S. The set speed is 5000 S.P.M for direct drive servo motor, but proper adjustment is acceptable.

## 馬達之安裝方式

## INSTALL THE MOTOR

安裝步驟：

1. 首先將連軸器(A)依順時針方向的第一顆螺絲(1)，固鎖於大心軸(B)上之長槽孔(3)，接著再鎖緊螺絲(2)。
2. 將橡膠緩衝墊(C)，以單面有2凸台記號(4)那端，對準連軸器(A)上之圓槽(5)後壓緊。
3. 將馬達(D)上之內槽扣孔與橡膠緩衝墊(C)上之凸台(7)互相扣接壓緊結合。
4. 將馬達(D)以螺絲(8)與墊片(9)鎖固於機體上。

注意事項：

若馬達與連軸器未依上述位置正確組裝，將會導致針棒停針的位置點不對；馬達組裝正確情形下，當針棒置於上死點時，針棒的左針與針板面距離約7.8mm。

INSTALLATION PROCEDURE:

1. Attach coupling (A) to lower main shaft (B) by fitting the first setscrew (1) to the long groove (3) of shaft, then tighten it and the other setscrew (2).
2. Attach rubber cushion (C) with the side of two projections (4) to coupling (A) by fitting projections to notches (5).
3. Attach motor (D) to rubber cushion (C) by fitting the inside projections to notches (7) on rubber cushion.
4. Use screws (8) and washers (9) to tighten motor (D) on machine body.

CAUTION:

Check to be sure that the "motor and coupling are installed correctly" as so to prevent needle bar from stopping on wrong position. If motor is installed correctly, the distance between the left needle on needle bar and needle plate will be 7.8mm when needle bar is in its highest dead point.

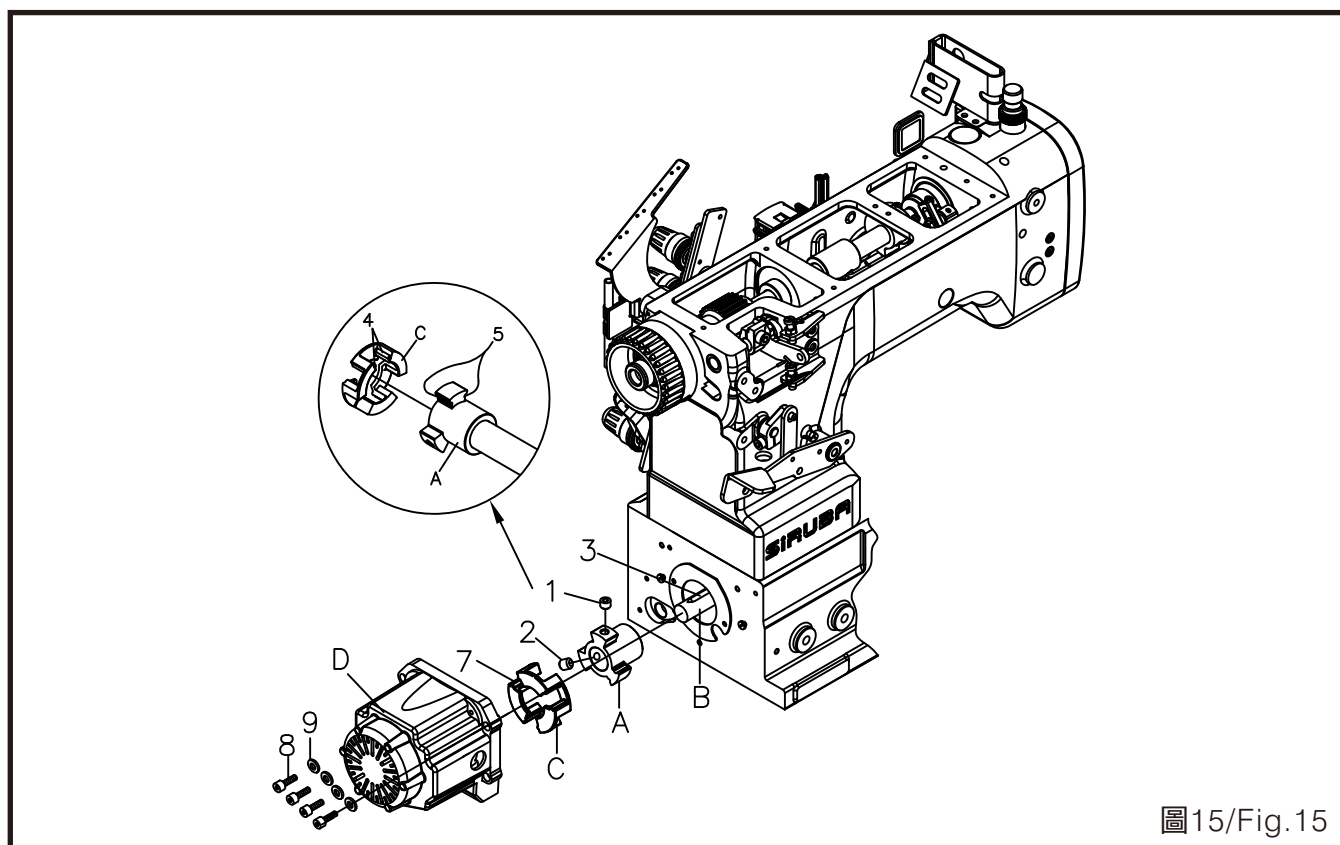

## 馬達與皮帶

## MOTOR AND BELT

1. 一般機種用之離合器馬達，1/2馬力(或400W)，3相2極；伺服馬達600W單相；定位馬達600W單相。可用外掛式或內藏式定位器，M番V型皮帶。
2. 直驅伺服馬達為600W，單相220V。
3. 馬達安裝時，機器上皮帶輪與馬達皮帶輪的中心線須為一直線。

1. General types: clutch motor, 1/2 hp (400w), 3 phases 2 poles. Servo motor, 600W, 1 phase. Positioning motor, 600W, 1 phase. Built-in or outside synchronizer are both acceptable. The belt type is M style V shape.
2. Direct drive servo motor is 600W, 1 phase, 220V.
3. The center lines of the motor and the machine pulley must be aligned with each other when installing the motor.

## 穿線方法

## HOW TO THREAD

請確實按照圖示為各種不同縫合情況穿線，錯誤之穿線將引起斷線跳針或車縫不平坦等現象。(圖20)

Follow the procedures shown in the figure for threading. Wrong threading may cause thread breaking, skipping stitch, puckering or unexpected sewing. (Fig. 20)

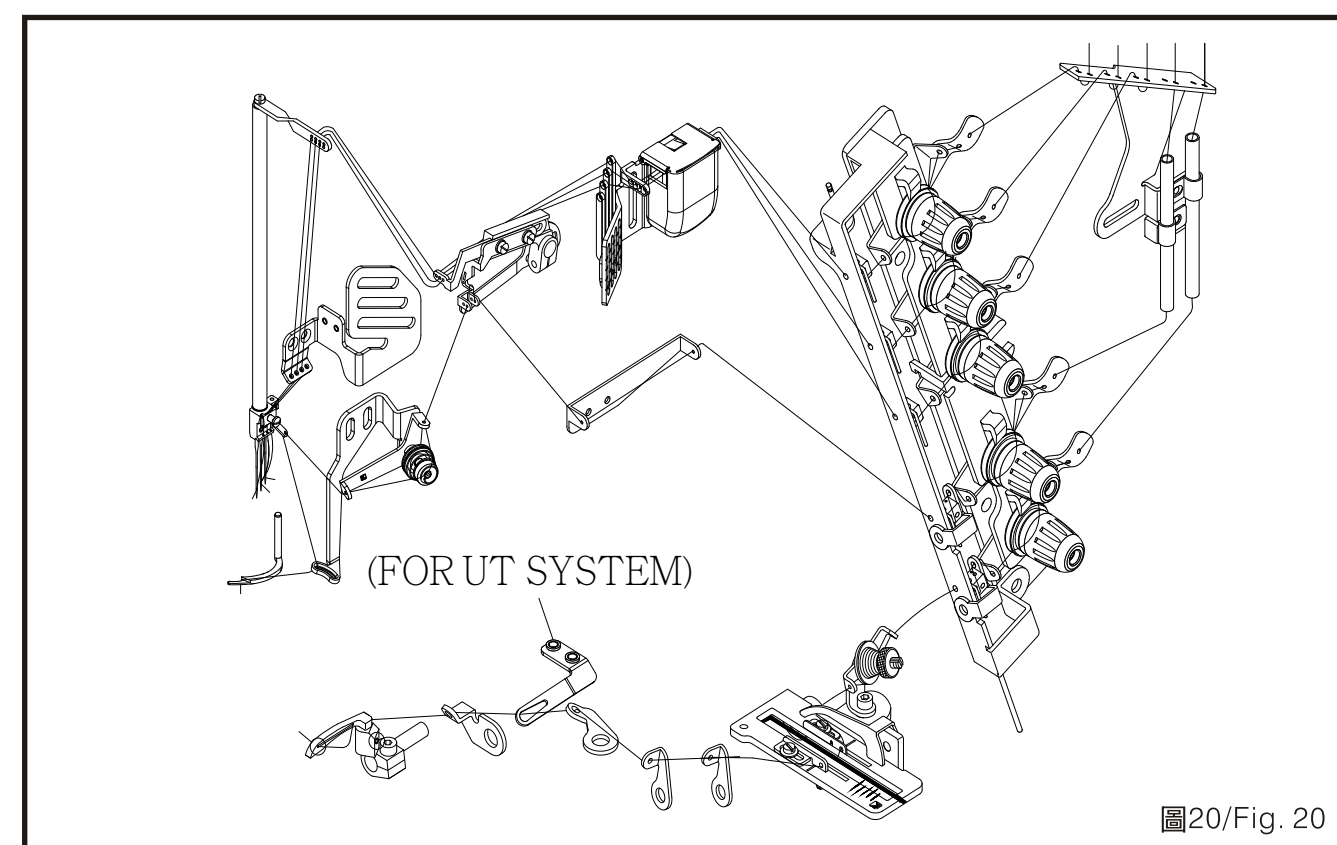



## 線鬆緊度調整

## ADJUST THE THREAD TENSION

拉線強弱必須根據：

1. 車縫布料種類
2. 料質厚薄
3. 線
4. 縫距

等不同而做調整，將控制鈕順時鐘方向旋轉時，線越緊，反之則越鬆。(圖20)

The tension of the thread should be adjusted according to:

1. The material type
2. The thickness of the fabric being sewed;
3. The thread;
4. The stitch length.

If you turn the thread tension knob clockwise, thread will be tighter. If you turn it counter-clockwise, will be looser. (Fig. 20)

## 針線挑線桿調整

## ADJUST THE NEEDLE THREAD TAKE-UP

1. 轉動手輪使針棒位於最低位置時，針線控桿搖臂①的上邊必須成水平，必要時放鬆螺絲④調整之。(圖 21)

2. 將螺絲②鬆開，調整 A，B 兩點的距離約 75 mm 再鎖緊。

註：

欲將針線條鬆時，將挑線桿③向左方向移動。

欲將針線條條緊時，將挑線桿③向右方向移動。

3. 上叉挑線桿⑤不要調動。

1. When turning the pulley and make the needle bar in the lowest position, the top edge of the needle thread take-up ① should remain horizontal. To adjust the position of the take-up if necessary, loosen the screw ④ . (Fig.21)

2. Loosen screw ② to adjust the length between point A and B to be about 75 mm, then fasten it tightly.

Note:

To loosen the needle thread, turn the needle thread take up ③ toward the left. To tighten the needle thread, turn the needle thread take up ③ toward the right.

3. Do not move the spreader thread take-up ⑤ when making above adjustments.



圖21/Fig. 21

## 上叉線挑線桿調整

## ADJUST THE SPREADER THREAD TAKE-UP

1. 當上叉挑線桿①擺至最高點時，另一張線桿②上的小孔 A 必須與張線桿①上之長溝底同高。(圖 22)

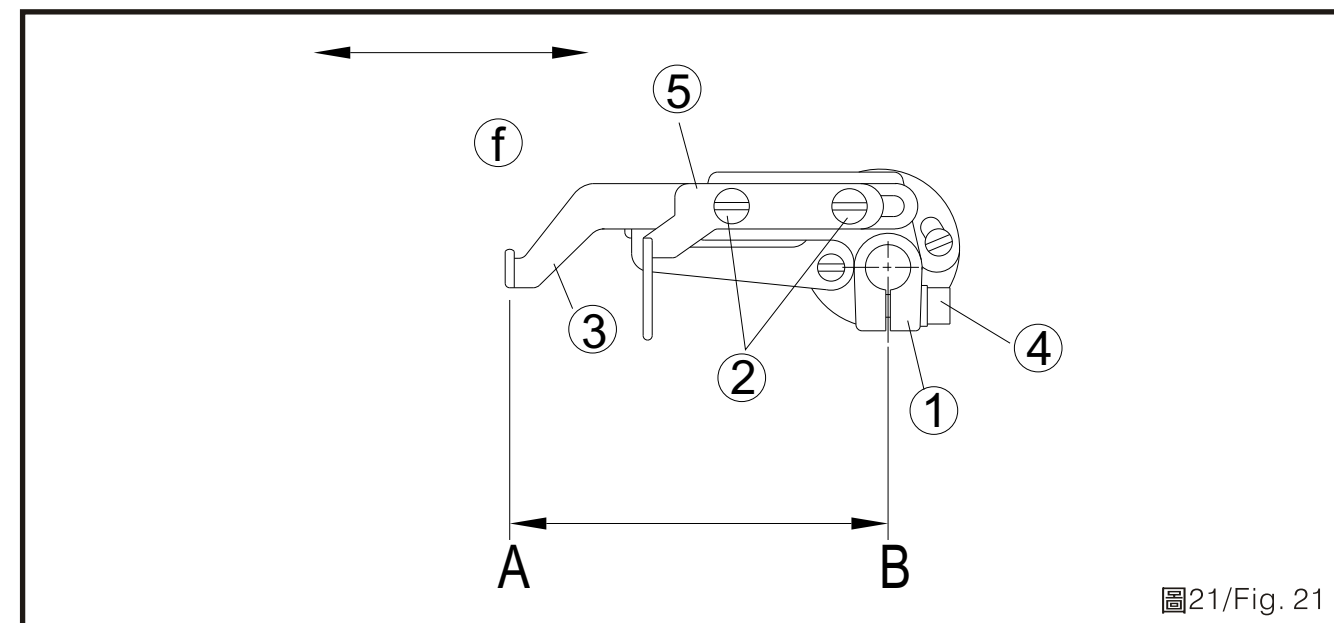
2. 必要調整時，先鬆開螺絲③及④，上下擺動上叉挑線桿②，調整後鎖緊之。

1. When the spreader thread take-up ① is adjusted to the top, the small hole A of the other spreader thread take-up must be at the same level with the long groove of the Spreader Thread Take-up ① . (Fig.22)

2. For necessary adjustment, loosen screw ③ and ④ first, move the Spreader Take-up ② up and down, and then fasten the screws again.



圖22/Fig. 22

## 押具調整

## ADJUST THE PRESSER FOOT

鬆開螺絲①並左右搖擺，調整押具②，使尖端剛好位於押具針孔如示之中心。調整後，再鎖緊螺絲①。(圖23)

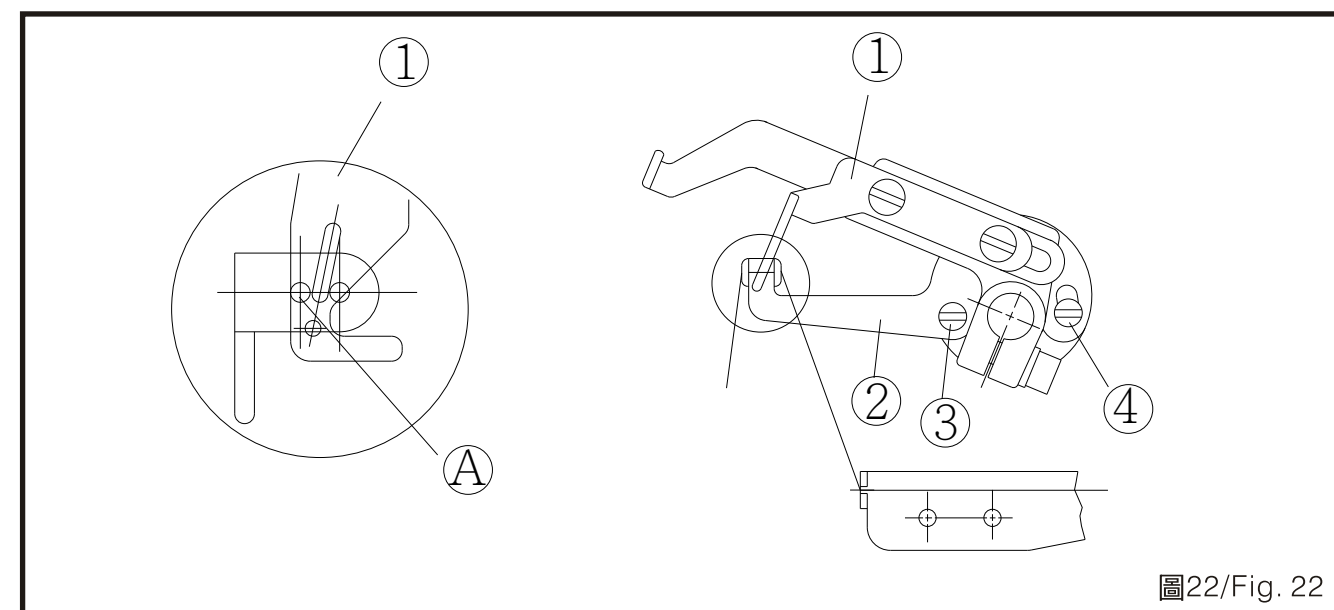
Loosen screw ① and adjust presser foot ② to a proper position to make the needle tip to be at the center of presser foot's eyelet as shown. After adjusting, tighten screw ①. (Fig. 23)

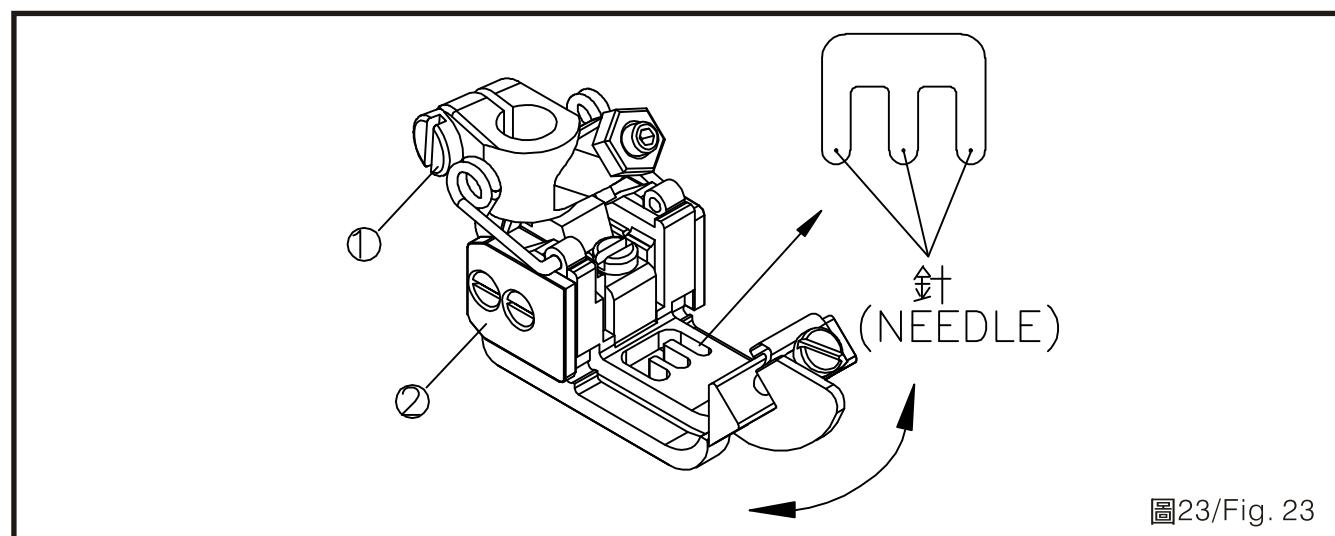

## 押具壓力調整

## ADJUST THE PRESSER FOOT PRESSURE

1. 在布料推送順暢且縫合完美之情況下，押具壓力盡量輕一些。(圖24)
2. 調整時可放鬆螺帽A將螺桿B往順時針或逆時針方向調整。順時針調整壓力變大，反時針壓力變小。

1. The pressure of the presser foot should be as light as possible when the cloth can be feed and sewed smoothly. (Fig. 24)
2. To adjust the pressure, loosen screw A and turn screw nod B. Turn the nod B clockwise to make pressure bigger. Turn the nod B counter-clockwise to make pressure smaller.

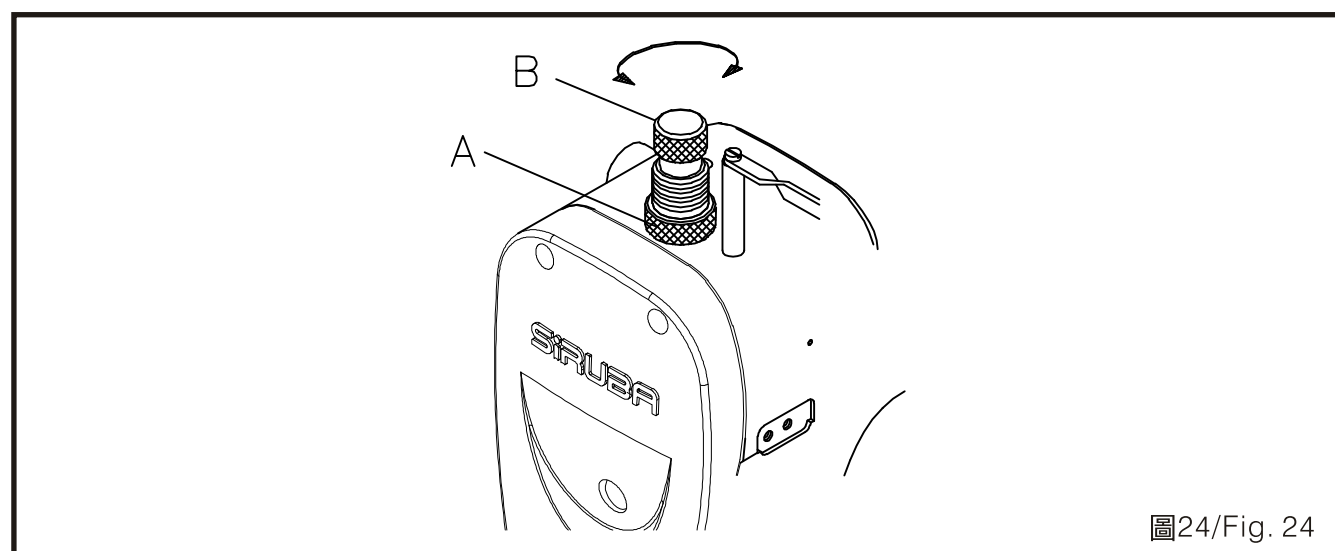

## 縫目長度調整

## ADJUST THE STITCH LENGTH

針距大小由1.4至3.6 mm或7-18針/寸無階段性調整，調整時：

Stitch length can be adjusted variably in range from 1.4 mm~3.6 mm, or 7-18 stitches per inch. While adjusting,

1. 旋鈕A往+方向轉動，縫目變大。(圖25)

1. Turn the nut A + direction, the stitch length will be bigger. (Fig. 25)

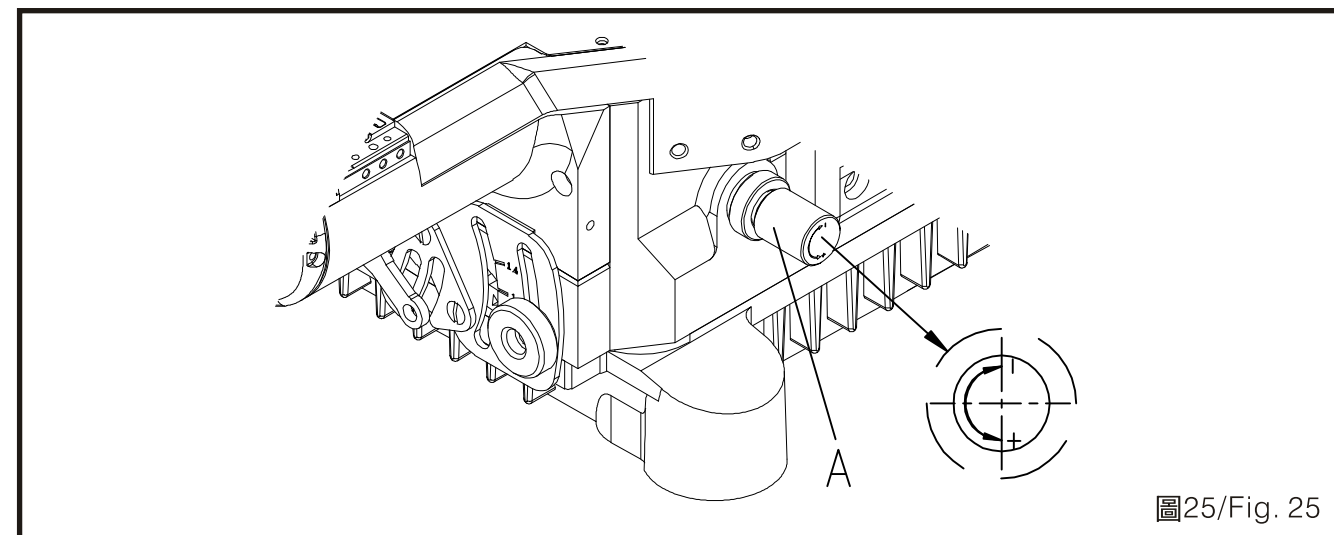

2. 旋鈕A往-方向轉動，縫目變小。

2. Turn the nut A to - direction, the stitch length will be smaller.

註：  
調整時縫目在最大時，送料具以不碰到針板溝為原則。

NOTE:  
While the stitch length is the maximum, the major principle is that the feed dog should not touch the needle plate slot.

## 差動比調整

## ADJUST THE DIFFERENTIAL RATIO

本機器之差動比可從1:0.8調整至1:1.4。鬆開旋鈕C，上下移動連桿D可調整之。往下差動比變小，往上差動比變大。(圖26)

The differential ratio of this machine is adjustable from 1:0.8 to 1:1.4 by loosening nut C, and then moving the connecting rod D up and down. Move the connecting rod downward to make the ratio smaller. Move the connecting rod upward to make the ratio bigger. (Fig. 26)

- \* 欲使布料伸張車縫，將C旋鈕放鬆，往下移。
- \* 需要摺景車縫時，將C旋鈕放鬆，往上移。

- \* To strength the cloth, loosen nut C, and move the rod downward.
- \* To gather the cloth, loosen nut C, and move the rod upward.



圖26/Fig. 26

## 潤滑

## LUBRICATION

1. 請選用MOBIL #10 或 ESSO #32或同級之潤滑油，勿使用過濃或過稀之潤滑油。
  2. 由於新機器在裝運前已將油倒盡，因此新機器在使用前必須注入新油，轉開螺絲A將油注入機器中，待油量滿至油標指示H即可，請勿超過油標上限H，以防漏油。B為油量下限標線。(圖27，圖28)
1. Please use Mobil #10 or Esso #32 or its equivalent. Do not use any oil that is too concentrated or too light.
  2. The lubricating oil has been drained from the machine before delivery. Therefore, lubricate with new oil before using the new machine is necessary. Remove the screw A and oil the machine until the amount indicate line reaches where under the mark line H. Please do not pour over the max H to prevent oil leakage. The mark line B is the lower limit mark line. (Fig. 27, Fig. 28)

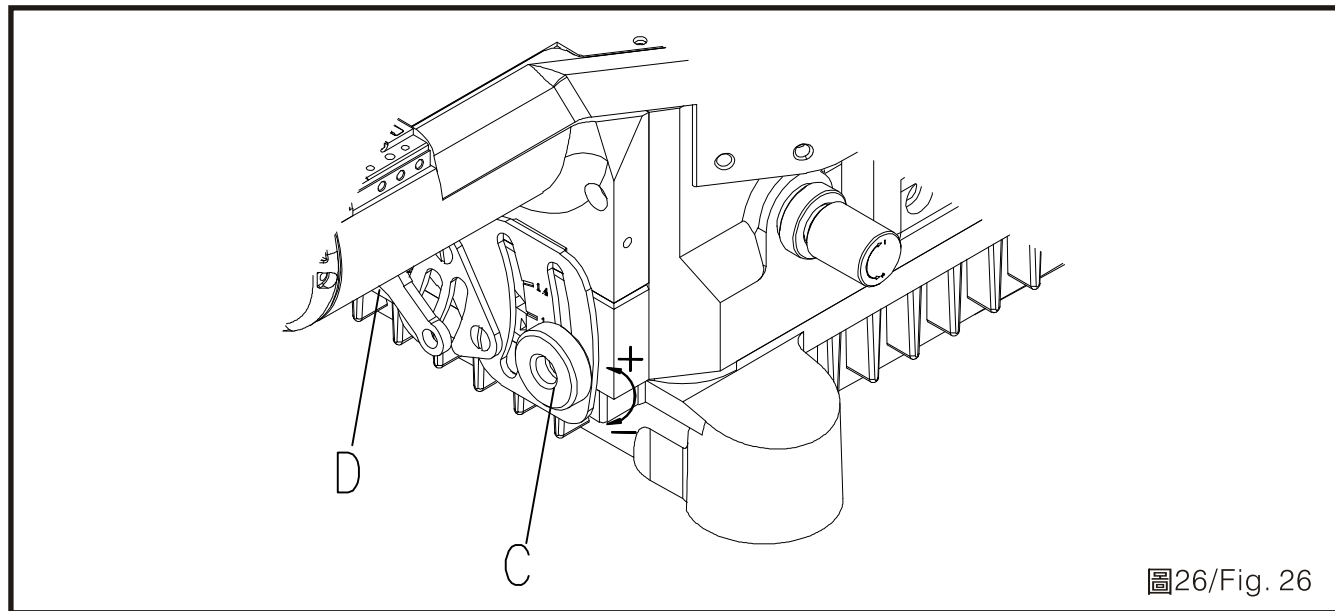

圖27/Fig. 27



圖28/Fig. 28

3. 每天必須檢視，如果油已低於油標指示窗之下限，必須加注新油。當機器開始運轉後，在操作前，檢視整個潤滑系統是否暢順。
- \* 開箱之新機器或許久未使用的機器，如重新要使用時，請在針棒上下部份加些油潤滑。
3. Check the oil every day. If the oil is already below the min line, please oil a.s.a.p. When the machine starts operating, please check if the lubrication device is smooth before using it.
- \* For a brand new machine or an idling one, please lubricate the needle bar before starting operation.

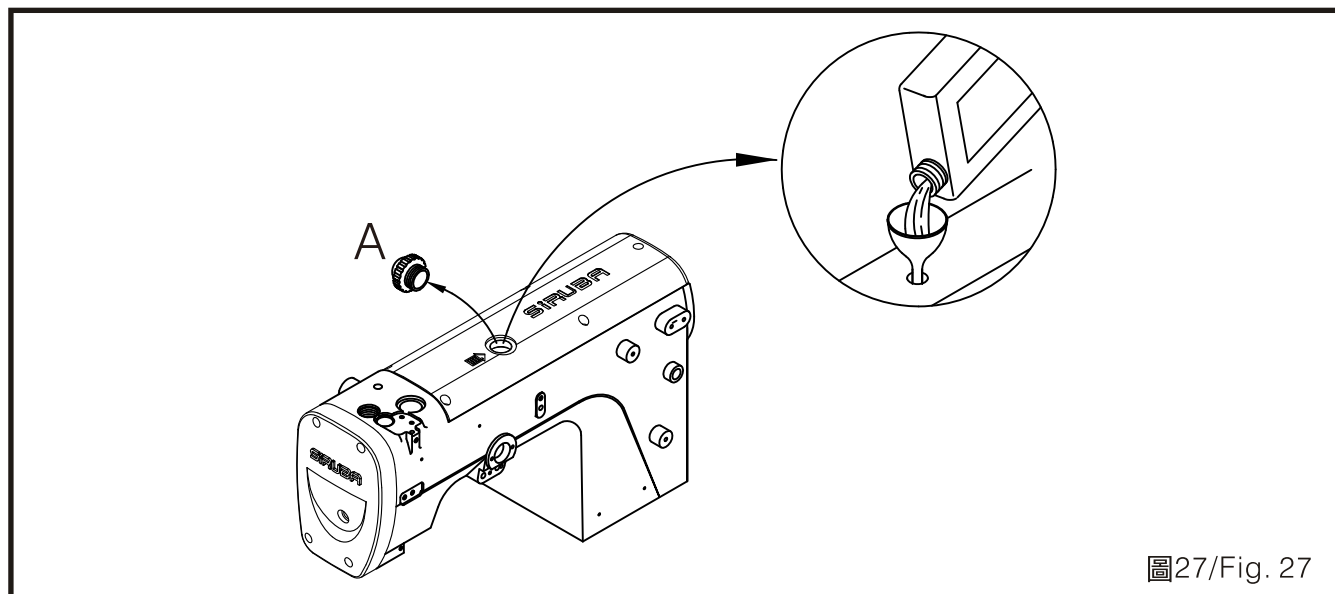
## 潤滑油之注入與更換

## LUBRICATION AND DRAINAGE

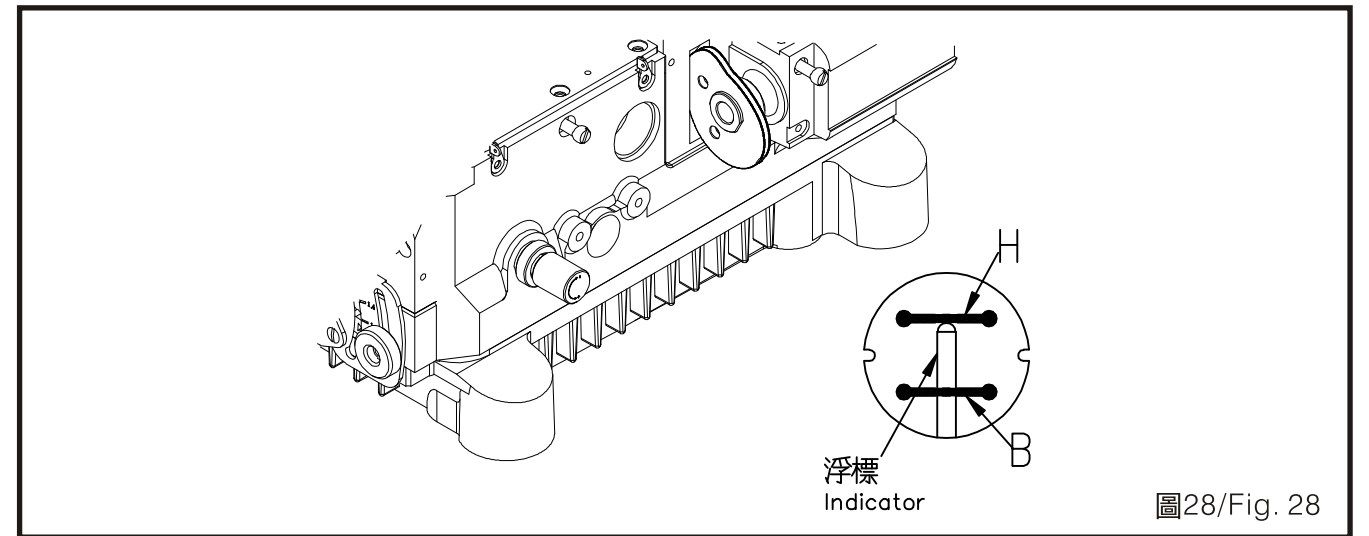
1. 將螺絲D鬆開，使油槽之油完全排出後再鎖緊。(圖29)
  2. 為延長本機器壽命，請於開始使用四星期後更換新油，爾後約3~6個月更換一次。
1. Loosen screw D, and drain all the oil from the tank. Then fasten the screw D back tightly. (Fig. 29)
  2. To extend the lifespan of the machine, change oil after the initial four weeks operation. After that, change oil every 3-6 months.



圖29/Fig. 29

3. 本機器特別裝有濾油器，約每使用一個月後應卸下清洗，必要時得換新品。(圖30)
4. 機器運轉一段時間後，內部會積布屑棉絮，應定期清除，避免積壓過多造成漏油。

3. This machine is equipped with an oil filter, and the filter must be cleaned every month, or replace the filter if necessary. (Fig. 30)
4. When the machine runs after a period of time, you need to clean the fiber and lints jammed inside the machine to avoid oil leakage problem.

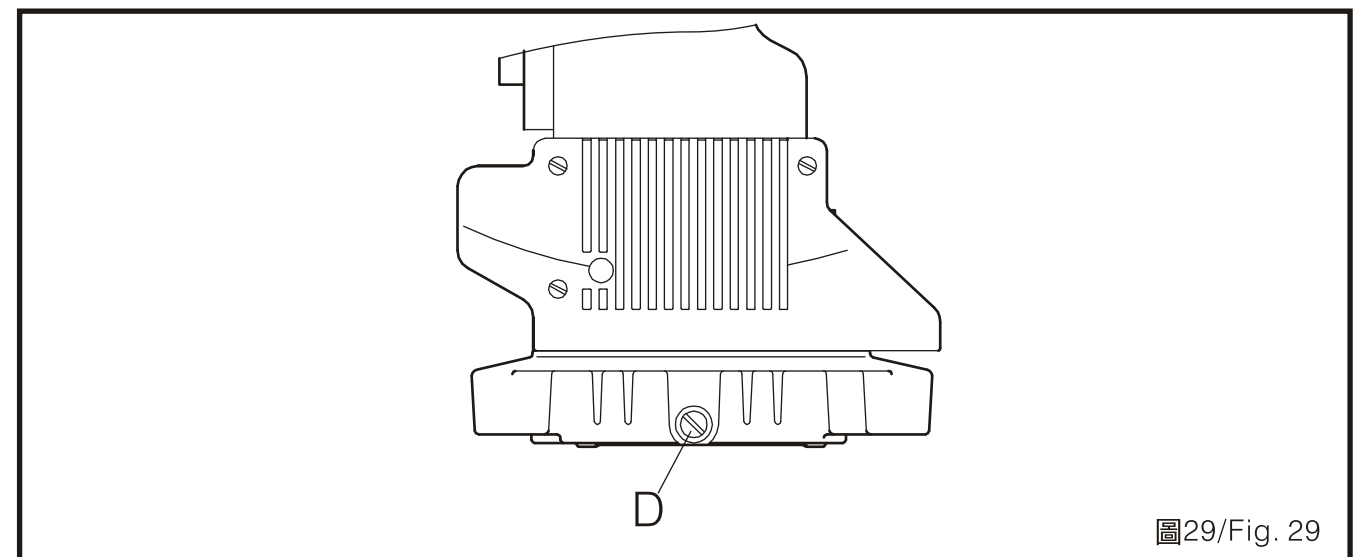

圖30/Fig. 30

### 操作環境照明

### LIGHTENING OF THE OPERATION ENVIRONMENT

提供一個警示標誌，告知使用者：工業用縫紉品或是縫紉系統必須在該縫紉區域未啟動照明裝置前，禁止插電或通電；照明裝置的最大輸入功率應該能夠輕易辨識，當照明裝置被重置或移動的時候，警示標誌也應設置在照明裝置插座上或是附近。警示標示如圖31所示

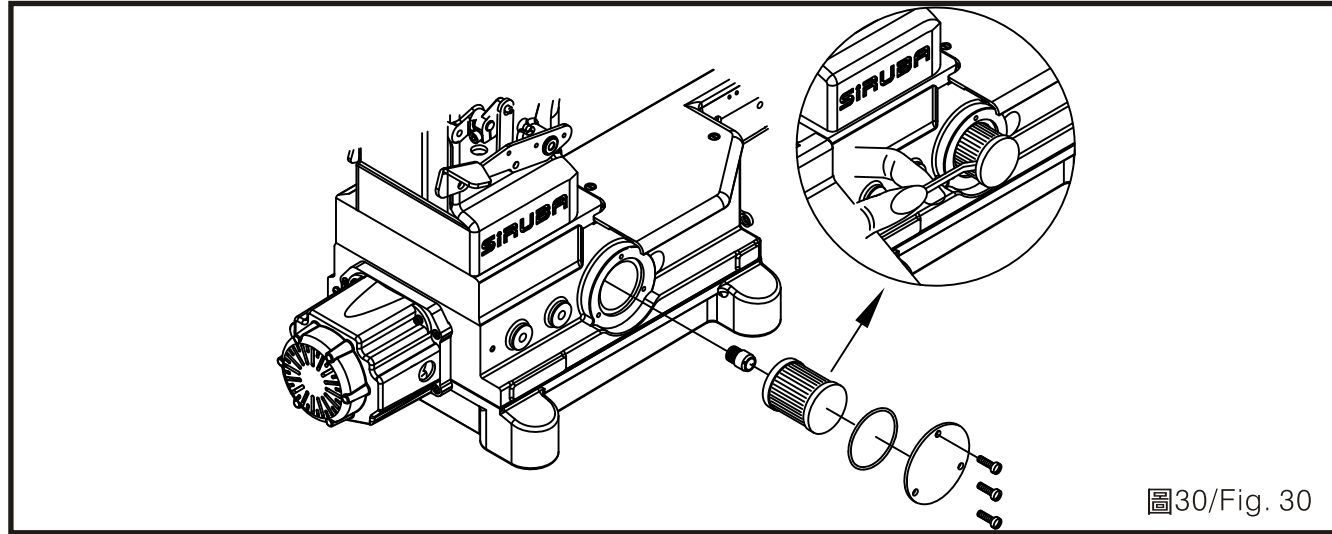
Provide a warning that an industrial sewing unit or sewing system must always be unplugged from the local lighting of the sewing area before relamping, the marking of maximum rated input of a lamp shall be easily discernible while the lamp is being replaced indicated on or near the lamp socket as shown on Fig. 31.

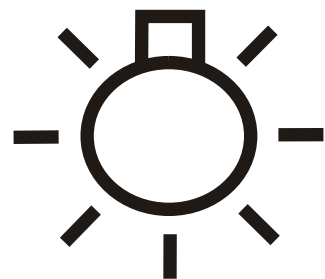

最大流明…… 510 流明  
Maximum…… 510 Lum  
最小流明…… 430 流明  
Minimum…… 430 Lum

圖31/Fig. 31

### 操作者條件

### CONDITIONS OF ALL OPERATORS

1. 熟讀並了解使用說明書內容。
2. 認識機器各部功能及注意事項。
3. 了解各警告標籤之意義。
4. 了解熟悉機器之操作方式。
5. 操作者須保持精神狀態良好。
6. 操作者須穿著合宜適當之工作服。
7. 視需要培養操作者使用機器之熟練度。

1. Read and understand well the content of this instruction book.
2. Know the functions of major parts and understand the notices.
3. Truly realize the meanings of all warning tags.
4. Realize and be familiar with how to operate this machine.
5. Operators have to keep well mental status.
6. Operators shall wear appropriate and proper working suits.
7. Develop the familiarity of how to operate the machine if needed.

### 針與線之冷卻與潤滑

### LUBRICATE AND COOLING OF NEEDLE AND THREADS

使用矽油注滿油槽以防止斷線。(圖32)

Fill the reservoir with silicone oil to prevent the thread from breaking. (Fig. 32)



圖32/Fig. 32

註：

矽油可潤滑縫線，防止針高速運轉時斷線；但縫紉時，縫線與布料縫合處會有些微矽油附著。對於成衣製品有特殊要求之情況，應視狀況加或不加矽油。

NOTE:

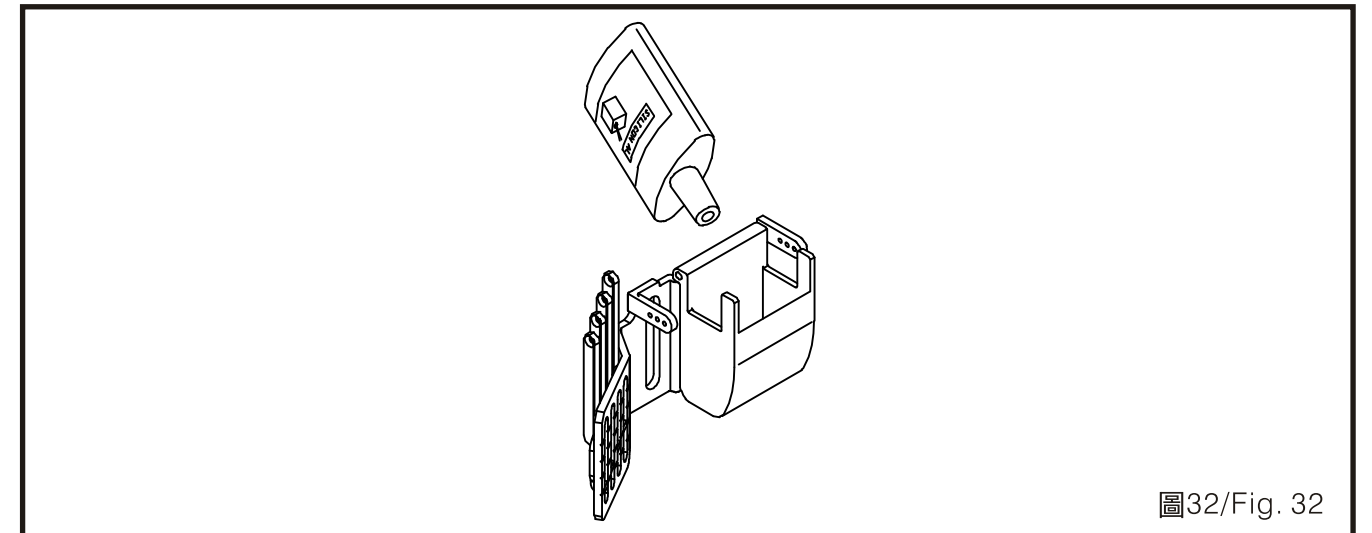
When the sewing machine is running, the silicone oil can prevent thread breaking from pulling and dragging. However, there will be some oil on the fabric and thread. For some particularly special requests of the finished products, add the silicon oil or not depending on the situations.





**注意CAUTION**



清潔作業前，請切斷電源。當誤觸起動開關時，縫紉機動作易導致人員受傷。  
Turn off the power switch before carrying out cleaning. The machine may operate if the treadle is pressed incautiously, which could result in injury.



加潤滑油和黃油時，務必戴好保護眼鏡和手套，以防潤滑油進入眼中或沾在皮膚上，易引起發炎。  
Be sure to wear protective goggles and gloves when handling the lubricating oil and grease so that they do not get into your eyes or onto your skin, otherwise inflammation can be resulted.



潤滑油或黃油不能飲用，否則將會引起嘔吐和腹瀉，將油放在小孩拿不到的地方。  
Furthermore, do not drink or eat the oil nor the grease for they can cause vomiting and diarrhea. Keep the oil away of the reach of children.

縫紉機頭倒下或豎起時，請以雙手進行操作。  
Use both hands to hold the machine head when tilting or returning it to its original position.



單手操作時，因縫紉機的重量較重，萬一滑落易導致受傷。  
If only using one hand to move the machine, the weight of the machine head may cause slipping and you may get hurt.

為了保持縫紉機的機能,且能長久的使用,請每日加以保養。另外,縫紉機如果長時間未使用,請進行以下的保養後再使用。

For keeping the machine quality and lengthening the usage term of this sewing machine, please maintain it everyday. In addition, before first use after a long idling time, please follow the following steps to maintain.

《保養》

1. 抬起押具
2. 將兩個螺絲①拆下，然後拆下針板②。
3. 以軟毛刷清除送布牙③上的布屑。(圖33)
4. 清潔後將針板②裝上。
5. 後傾斜縫紉機頭部

《CLEANING》

1. Raise the presser foot.
2. Remove the two screws ①, and then remove the needle plate ②.
3. Use a soft brush to clean dust and lints on the feed dog teeth ③. (Fig. 33)
4. Install the needle plate ② after doing the above cleaning.
5. Tilt back the machine head.



圖33/Fig. 33

《定期保養項目》(表3)

《Periodical Maintenance Items》(Table 3)

保養循環 Maintenance Cycle	保養項目Maintenance Items
每天 Daily	1. 清潔送料具上之棉絮 Clean the lint on the feed dog.
	檢查油盤是否有足夠之液態油。(油量在油鏡之上、下兩紅漆記號間) 2. Check if there has enough liquid oil inside the oil pan. (The amount should be between the red up and down paint mark of the oil level gauge.)
	3. 保持機器及操作台清潔 Keep the machine and the operation table clean.
每週 Weekly	1. 保持電源外觀乾淨 Keep the power cords looking clean and neat.
	2. 保持操作面板乾淨 Keep the operational panel clean.
	3. 檢查電源零件是否鬆脫或在正確位置 Check if the power parts is loosening or still at the right position.
每三個月 Quarterly	1. 更換油盤內之液態油 Replace the liquid oil inside the oil pan.
每年 Annually	1. 檢查傳動皮帶是否疲乏或毀損 Check the transmission belt to see if it is weariful or damaged.

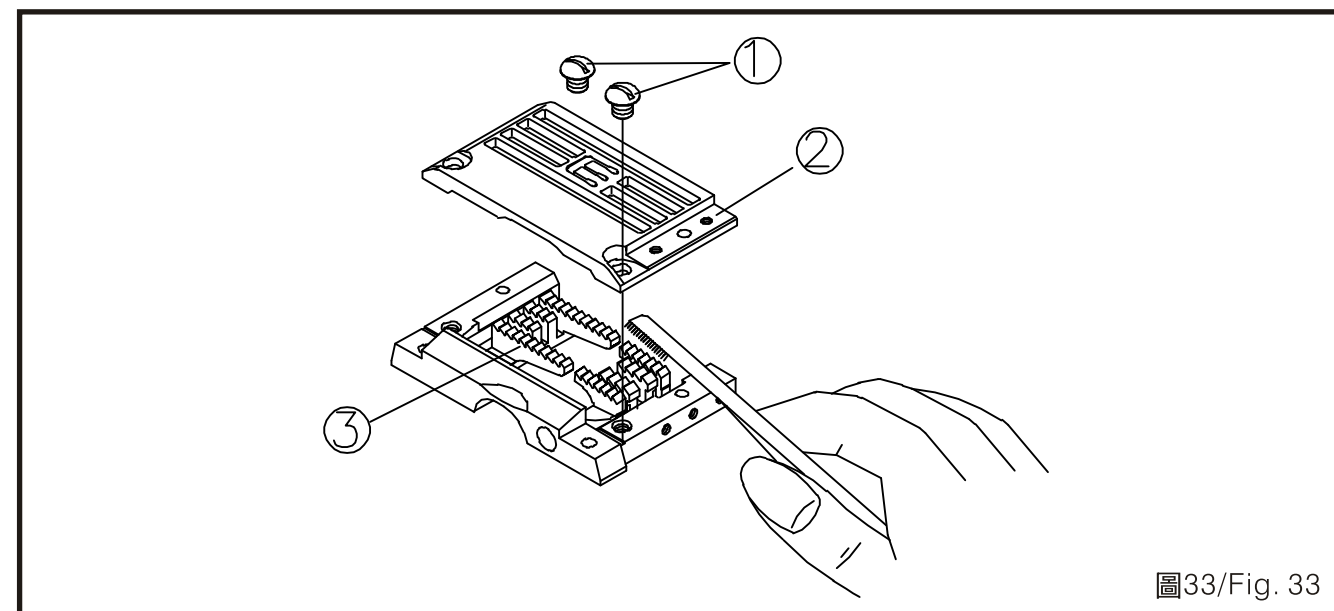
表3/Table 3

針之更換

REPLACE THE NEEDLES

1. 選用針之規格與尺寸請參照表4。

1. See table 4 for the sizes and specifications of the needles.

針的系統 Needle System	針的尺寸 Needle Size	
	2針 2 Needles	3針 3 Needles
SCHMETS UY128GAS	#70	#75
ORGAN 128GAS	#10	#11

表4/Table 4

2. 旋開螺絲①並取下針，將新針插至針座最底端，並使針之長溝面向自己。(圖34)
2. Loosen screw ①, and then pull out the needles desired to replace. Insert the new needles into the holder holes till reaching the end, and let the long groove of the needle face you. (Fig.34)
3. 重新鎖緊螺絲①。  
\* 特殊機種針之代號請參考規格件表。
3. Fasten screw ①.  
\* Needle size of special model, please refer to specification chart.
- \* 請選用正確針之型號，如果型號錯誤。有可能會引起跳針、斷線。  
\* Please use correct needle, or it will cause



圖34/Fig. 34

## 結束密縫調整

## ADJUSTING INTENSIVE SEWING

結束密縫說明：結束密縫說明：結束密縫功能設計，將結束密縫驅動桿①以鏈條②鉤住，以膝動方向將結束密縫驅動桿①往下拉伸，透過結束密縫功能，可使車縫末端線跡更密集，使縫線跡不易脫落，其標準配置為膝動，亦可選配由電子馬達控制箱動作，進行車縫前端和末端結束密縫。(圖35)

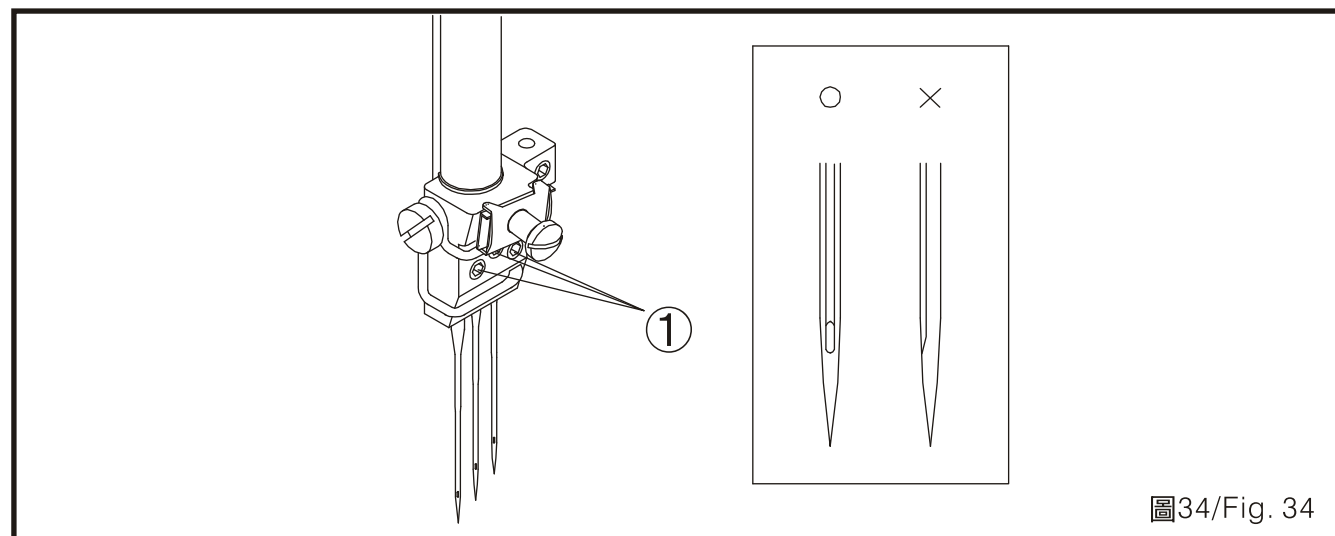
The instruction of pneumatic end intensive: End intensive sewing function-hook the end intensive sewing driving lever ① by the chain ② and stretch down the end intensive sewing driving lever ① by foot-action, which enable the end stitch more intensive and strong. The standard equipment of end intensive sewing is foot-action, but the electronic motor control box can be option too. (Fig.35)

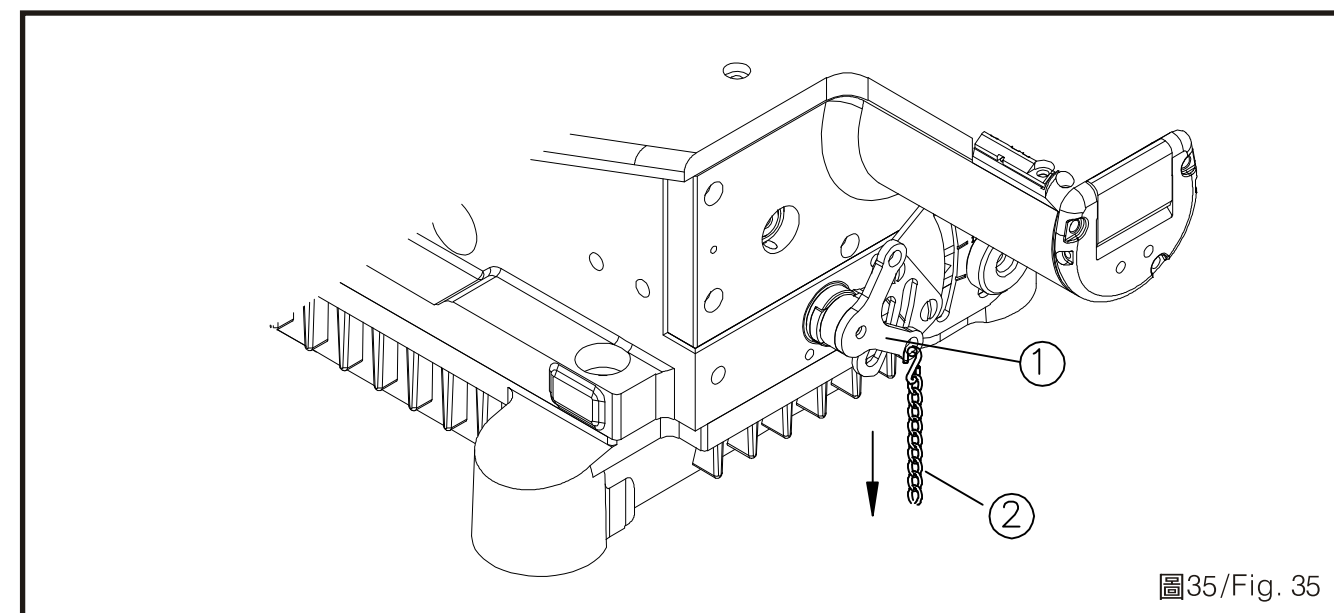

## 故障檢修

## TROUBLESHOOTING



### 注意CAUTION



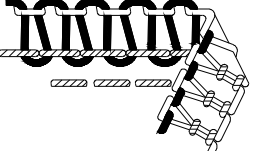
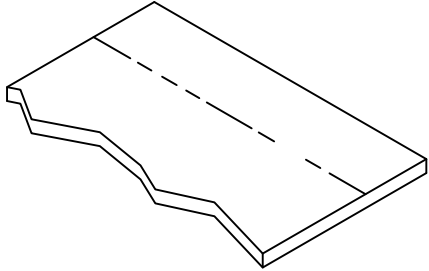

在進行故障檢修查詢之前，請先關閉電源並拔出電源，否則如果誤觸啟動開關，縫紉機會動作，易導致人身傷害。

Before processing the troubleshooting, please turn off the power switch and un plug the electronic cord. Otherwise, if touching the start switch incautiously, the sewing machine will function and will probably cause injuries happened o operators.

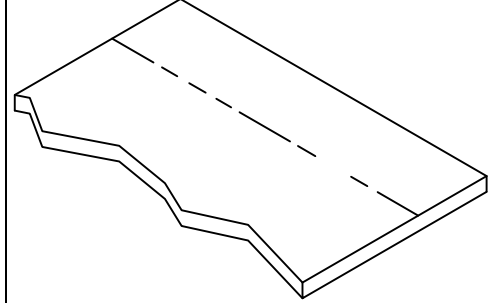
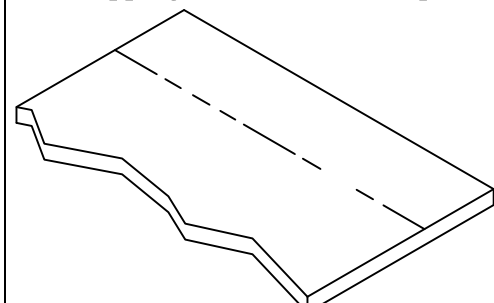
No.	現象 Problem	檢查及調整 Exam and Adjustment
1.	針線太過緊密/鬆疏 Needle thread too tight/ loose 	<ul style="list-style-type: none"> <li>●針線張力是否過大或過小? The tension of the needle thread is too loose or too tight?</li> <li>◎調整針線張力。 Adjust the needle thread tension</li> </ul>
2.	針線的跳線現象 The Skipping Stitch of Needle Thread 	<ul style="list-style-type: none"> <li>●車針的選擇不對? Choose the wrong needle?</li> <li>◎選擇配合布料的車針與縫線號碼。 Select the needle and thread number match the fabrics</li> <li>●車針不良? Bad needle?</li> <li>◎換新車針。 Change a new needle</li> <li>●車針與左勾針尖端之間有間隙? Any clearance between the needle and the top of the left looper?</li> <li>◎調整左勾針尖端與車針之間±0 Adjust the distance from the top of the left looper to the needle to be ±0</li> <li>●張力調整小彈簧不起作用? The small spring of tension adjustment does not function?</li> <li>◎(1)小彈簧不起作用時，要把彈簧拉緊一點。(注意)拉太長則會發生斷線。 (1) If the small spring does not function, pull it to be more tightened. (Note) The broken thread will happen if pull the spring too tight.</li> <li>(2)張力調整盤發生溝槽時，則須更換新調整盤。 (2) If there is any groove existing on the tension adjusting plate, please change a new one.</li> <li>●針線的張力太緊? The tension of the needle thread is too tight?</li> <li>◎(1)把針線張力全部放鬆些。 (1) Loose the tension of the needle thread a little.</li> </ul>

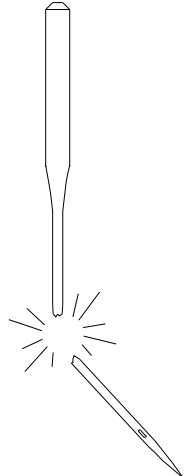
No.	現象 Problem	檢查及調整 Exam and Adjustment
2.	針線的跳線現象 The Skipping Stitch of Needle Thread	<ul style="list-style-type: none"> <li>(2)把針線的線路(A)調整在最高位置，使針線的勾線器(B)的針線放出量減少。 (2) Adjust the line (A) of the needle thread to the highest position, so that the release amount of the needle thread from thread hooking will decrease.</li> <li>(3)把線路(C)左傾一點，以增加勾針的線放出量。 (3) Lean the line (C) to left a little to increase the release amount of the looper thread.</li> </ul>
3.	右勾針線的跳線 The Skipping Stitch of the Right Looper Thread 	<ul style="list-style-type: none"> <li>●右勾針與車針之間隙太大? The space between the right looper and needle is too wide?</li> <li>◎右勾針向右退後時，和車針之間隙必須為0.1mm 乃使用正規的右勾針。(備有單針、雙針、原料、薄料用各機種最合適的右勾針) When the right looper turn right and backward, the distance to the needle has to be 0.1 mm, which is using the correct right looper. (The appropriate right looper for each type, such as single need, 2 needles, materials, and thin fabrics, are included)</li> <li>●雙針時，右勾針與左針之間隙大? The distance is too wide between the right and left needle when using 2 needles?</li> <li>◎由於右勾針安裝時的左右位置以及右勾針座上下運動位置之雙方關係，予以調整在勾針的運動軌跡，在右勾針下降時，將左針到右針的下降量予以減少。 Because the correlation of the left/right position of the right looper while assembling and the up/down moving position of the right looper seat, adjust the movement path of the looper. When the right looper descends, decrease the descending amount from left needle to right needle.</li> </ul>
4.	左勾針線的跳線 The Skipping Stitch of Left Looper 	<ul style="list-style-type: none"> <li>●左右勾針交叉時，右勾針不會勾到左勾針線? The right looper didn't hook the left looper thread while they are crossing each other?</li> <li>◎換新左勾針。(左勾針尖端磨損，要修正時，不得把頭部凸出處予以磨低(磨薄))。 Change the new left looper. (The top of the left looper is worn. When fix and replace, the protrusion for the looper top shall not be worn.)</li> </ul>

No.	現象 Problem	檢查及調整 Exam and Adjustment
4	左勾針線的跳線 The Skipping Stitch of Left Loper	<ul style="list-style-type: none"> <li>●右勾針尖端的磨損? The wear of the right looper top?</li> <li>◎換新勾針或用油石把尖端磨尖。 Change a new looper or use the oil stone to wear the top.</li> </ul>
5	斷針 Needle Broken 	<ul style="list-style-type: none"> <li>●車針的選擇不對? Choose the wrong needle?</li> <li>◎在布料不發生針孔的範圍內，使用粗一點的車針。 Use thick needle within the range that there will be no pinhole occurred on the fabric.</li> <li>●押具的安裝不良? Bad assembling of the presser foot?</li> <li>◎安裝時必須使用車針會插進押具落針處中央。 During assembly, make sure the needle can insert to the central point of the presser foot.</li> <li>●送布齒的安裝高低不對? Wrong assembling height of the feeding teeth?</li> <li>◎調整送布齒的高度為 0.8mm~1mm，同時保持適當的押具壓力。 Adjust the height of the feeding teeth to be around 0.8 mm to 1 mm. Meanwhile, keep the appropriate presser foot pressure.</li> <li>●縫線不良? Bad threading?</li> <li>◎縫線有結頭要事先加以處理後，重新穿線。 If there is any connecting part of the thread, it needs to be dealt first. Then, rethreading.</li> <li>●縫紉過程中是否在送入或拉出面料時用力過度? Is the material being pushed or pulled with excessive force during sewing?</li> <li>●機針是否安裝正確? Is the needle properly installed?</li> <li>◎如果機針安裝不正確，應正確加以安裝。 If it is incorrect, install the needle correctly.</li> <li>●機針是否彎曲?針尖是否斷裂起毛或針孔是否被堵住? Is the needle bent, is the needle tip broken, or is the needle hole blocked?</li> <li>◎更換機針 Replace the needle.</li> </ul>

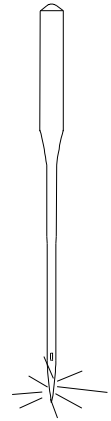
No.	現象 Problem	檢查及調整 Exam and Adjustment
5	斷針 Needle Broken	<p> <b>注意 Caution</b></p> <ul style="list-style-type: none"> <li>●如果斷針不慎掉入縫紉衣物中，會有很大的危險。 It is extremely dangerous to leave any pieces of broken needle sticking in the material.</li> <li>◎請盡可能找出斷掉的機針。 If the needle breaks, search for all pieces until the whole of the needle is found.</li> </ul>
6.	車針尖端受損 The Top of the Needle Damaged 	<ul style="list-style-type: none"> <li>●右勾針及車針高低不對? The right looper and the needle have wrong height position?</li> <li>◎車針在上死點附近時，用手指故意把車針向前彎曲，看看尖端會不會碰到右勾針，然後調整車針高低或右勾針的運動位置。 When the needle moves close to the upper dead point, push the needle forwards a little by finger. See whether the top of the needle touches the right looper or not. Then adjust the height of the needle position or the moving position of the right looper.</li> <li>●頂針片太靠近? The ejector plate is too close?</li> <li>◎裡面的頂針片必須在左勾針的尖端到達車針右側面時，就要從車針離開。前面頂針片與車針的間隙必須留大約 0.2mm。 The ejector plate inside must leave from the needle before the top of the left looper reaches the right side of the needle. The distance between the front ejector plate to the needle is about 0.2 mm.</li> <li>●針板安裝位置不對? Incorrect needle plate assembling position?</li> <li>◎把針板拉前安裝使 A 部分的間隙大一點。 When assembling the needle plate, pull it forwards a little so that the space of part A can be larger.</li> </ul>

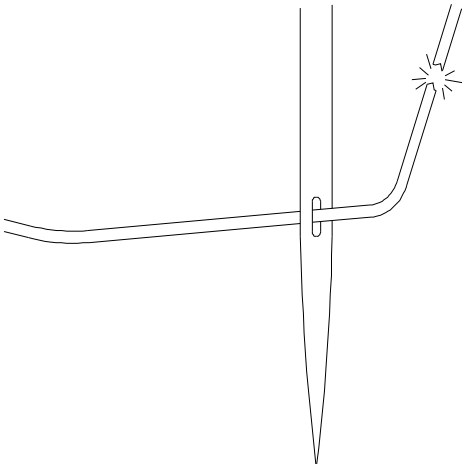

No.	現象 Problem	檢查及調整 Exam and Adjustment
7	斷線與縫合不順 Broken Thread and Rough/Uneven Stitch	 <ul style="list-style-type: none"> <li>●線架的線孔沒有磨光? The thread hole of the thread stand did not polish?</li> <li>◎用砂布把線孔周圍磨光。 Use emery cloth to polish the surroundings of the thread hole.</li> <li>●線的選擇錯誤? Choose the wrong thread?</li> <li>◎更換較好的線，使粗細線均勻。 Change a better thread to balance the threads.</li> <li>●線的張力調整不好? Cannot adjust to the best thread tension?</li> <li>◎注意左右勾針的線不要太鬆，要調整一支針線時也要注意有關的線變化。 Please be noted that the threads of the left/right looper should not be too loose. When adjust the position of one needle, the related changes of the threads are needed to be noticed.</li> <li>A. 拉緊針線→左勾針線會鬆→右勾針線會緊。 A. Pull the needle thread tightly→the left looper is looser→the right looper is tighter</li> <li>B. 拉緊左勾針線→右勾針線會鬆→針線也會鬆。 B. Pull the left looper thread tightly→the right looper is looser→the needle thread is looser, too.</li> <li>C. 拉緊右勾針線→左勾針線會鬆→針線會鬆。 C. Pull the right looper thread tightly→the left looper thread is looser→the needle thread is looser</li> <li>●押具彈簧調整不良? Incorrect adjustment of the presser foot spring?</li> <li>◎調整押具彈性配合所要用的布料 Adjust the presser foot flexibility to fit the fabric.</li> <li>●切刀磨損? The knife is worn?</li> <li>◎磨利刀口或更換新品。 Sharpening the knife or changing a new one.</li> <li>●差動比未配合? The differential ratio not match?</li> <li>◎調整配合布料的差動送料。 Adjust the differential feeding to match the feeding fabric.</li> </ul>

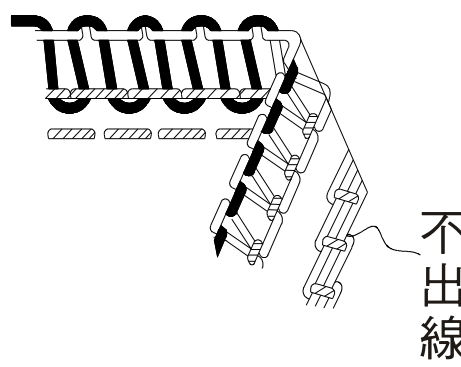
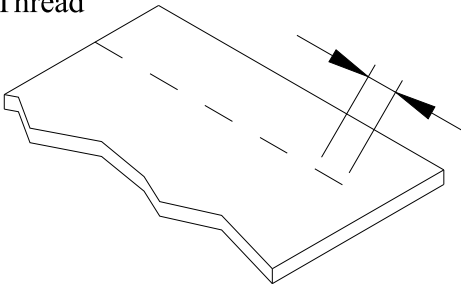
No.	現象 Problem	檢查及調整 Exam and Adjustment
8	環縫不出線 The Thread does not Come Out When Doing Chainstitch	 <ul style="list-style-type: none"> <li>●環勾針線凸輪調整不當? The cam of the chainstitch looper is not appropriate?</li> <li>◎調整適當的凸輪方位。 Adjust the cam to an appropriate position.</li> <li>●控線器不良? Thread tension device does not work well?</li> <li>◎(1)調整彈簧強度 (1)adjust the spring strength</li> <li>(2)拋光或換新 (2)polishing or changing a new one</li> <li>●押具後彈簧安裝不良? The presser foot rear spring did not assemble well?</li> <li>◎重新調整彈簧或換新，使押具活動自如，並試其壓力。 Readjust the spring or change a new one to make sure the presser foot can act smoothly and test its pressure.</li> </ul>
9.	粗細針不能分 Cannot Separate the Thin and Thick Thread	 <ul style="list-style-type: none"> <li>●偏心凸輪生鏽? The eccentric is rusty?</li> <li>◎清除阻塞部分使油通到凸輪上。 Clean the stuck part so the the oil can reach the cam.</li> <li>●偏心凸輪控制彈簧調整不當? Inappropriate adjustment of the eccentric cam control spring?</li> <li>◎調整適當之緊度，但不可太鬆。 Adjust to the proper tension, but should not be too loose.</li> </ul>
10.	大聲、異聲 Loud Noise, Strange Noise	<ul style="list-style-type: none"> <li>●心軸鬆動出聲? The main shaft is loose and has noise?</li> <li>◎把大心上的銅套之銅面膠清除，重新調整。 Clean the copper glue from the copper cover of the main shaft and readjust.</li> <li>●泵浦聲(沙沙聲)? Noise of the pump (scratchy?)</li> <li>◎用治具加壓泵浦齒輪，使運轉 3~5 分鐘即可。 Use the fixture to add pressure on the gear of the pump, and keep the pump running 3-5 minutes.</li> </ul>

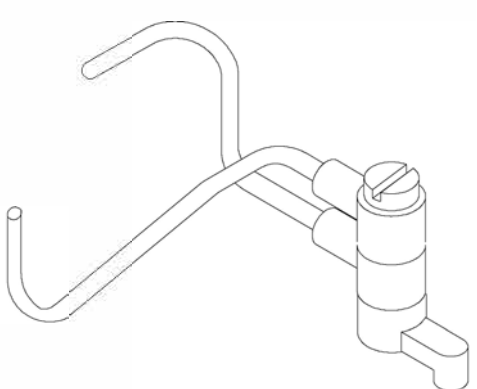
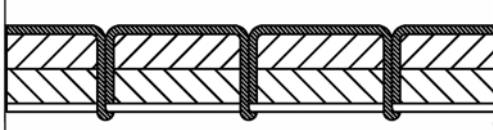
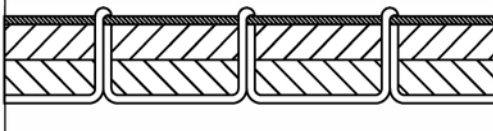
No.	現象 Problem	檢查及調整 Exam and Adjustment
10.	大聲、異聲 Loud Noise, Strange Noise	<ul style="list-style-type: none"> <li>●針棒鬆動? The needle bar is loosening?</li> <li>◎更換新品或磨合其接觸面使之間隙變小。 Change a new one or to polish the contacting surface so that the clearance is smaller.</li> <li>●皮帶輪出聲? Noise from the belt wheel?</li> <li>◎按基準調整之。 Adjust it based on the norm.</li> </ul>
11.	不能噴油 The Oil Does Not Splash	 <ul style="list-style-type: none"> <li>●泵浦不出油? The oil does not come out from the pump?</li> <li>◎(1)重新鎖正確位置 (1)Relock it to the correct position</li> <li>(2)重新組配泵浦中齒輪與心軸位置 (2)Reassemble the gear of the pump to the main shaft and adjust the position.</li> <li>●上機構不噴油? Upper mechanism does not splash the oil?</li> <li>◎(1)清除毛頭換新出油螺絲 (1)Clean the lints and change the oil releasing screw.</li> <li>(2)換新濾油器 (2)Change a new filter</li> <li>(3)清除污穢的東西或換新 (3)Clean the dirt or change a new one</li> <li>(4)用鐵絲疏通油路 (4)Use the iron wire to clean through the oil path.</li> </ul>
12.	針線不夠緊密 Upper Thread Is Not Tight	 <ul style="list-style-type: none"> <li>●針線張力是否過小，或勾針線張力是否過大? Is the upper thread tension too weak, or is the looper tension too strong?</li> <li>◎調整針線張力或勾針線張力。 Adjust the upper thread tension or looper thread tension.</li> </ul>
13.	勾針線不夠緊密 Lower Thread Is Not Tight	 <ul style="list-style-type: none"> <li>●勾針線張力是否過小，或針線張力是否過大? Is the looper thread tension too weak, or is the upper thread tension too strong?</li> <li>◎調整勾針線張力或針線張力。 Adjust the looper thread tension or upper thread tension.</li> </ul>

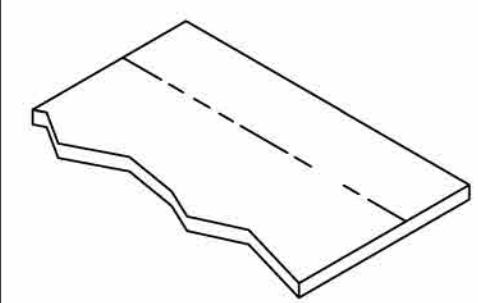
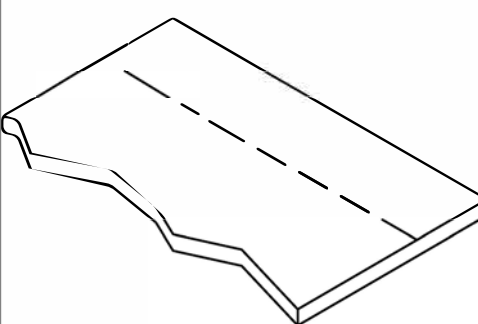
No.	現象 Problem	檢查及調整 Exam and Adjustment
14.	縫紉時出現跳針 Skipped Stitches Occur While Sewing	 <ul style="list-style-type: none"> <li>●機針是否彎曲?針尖是否鈍化或起毛? Is the needle tip bent? Is the needle tip blunt?</li> <li>◎如果針尖彎曲或斷裂起毛，應予以更換。 If the needle tip is bent or broken, replace it.</li> <li>●機針是否安裝正確? Is the needle properly installed?</li> <li>◎如果機針安裝不正確，應正確加以安裝。 If it is incorrect, install the needle correctly.</li> <li>●縫線是否穿引正確? Is the machine properly threaded?</li> <li>◎如果穿引不正確，應正確穿引縫線。 If it is incorrect, thread the thread correctly</li> <li>●壓具壓力是否過小? Is the presser foot pressure too weak?</li> <li>◎調整壓具壓力。 Adjust the presser foot pressure.</li> <li>●機針是否太細? Is the needle too thin?</li> <li>◎更換大一號的機針。 Replace the needle with a needle that is one rank thicker</li> <li>●壓具是否太高? Is the presser foot too high?</li> <li>◎調整壓具高度。 Adjust the height of the presser foot.</li> <li>●挑線簧是否太弱? Is the thread take-up spring too weak?</li> <li>◎調整挑線簧的張力 Adjust the tension of the thread take-up spring.</li> </ul>
15.	縫紉開始時出現跳針或脫線 Skipped Stitches Or Unraveled Thread At Sewing Start	 <ul style="list-style-type: none"> <li>●挑線簧張力是否過大? Is the thread take up spring tension too strong?</li> <li>◎減小挑線簧張力。 Reduce the tension of the thread take-up spring.</li> <li>●挑線簧活動範圍是否過大? Is the thread take-up spring operating range too large?</li> <li>◎降低挑線簧的位置。 Lower the position of the thread take-up spring.</li> </ul>

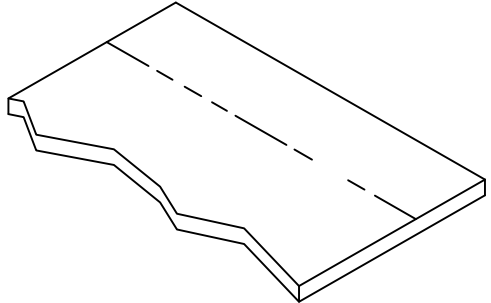
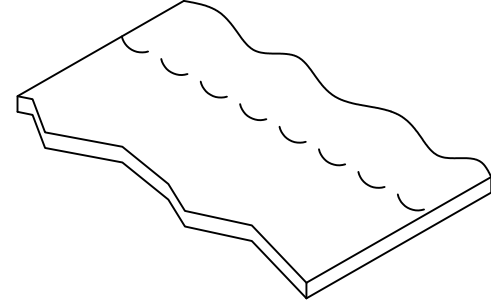
No.	現象 Problem	檢查及調整 Exam and Adjustment
15.	縫紉開始時出現跳針或脫線 Skipped Stitches Or Unraveled Thread At Sewing Start	<ul style="list-style-type: none"> <li>●切線後，針線殘留量是否過短? Are the trailing lengths of the upper threads too short after thread trimming?</li> <li>◎調整張力 Adjust the tension</li> <li>●縫線是否剪切整齊? Are the threads not being trimmed cleanly?</li> <li>◎將固定刀磨利，或視需要更換固定刀和活動刀。 Sharpen the fixed knives, or replace the fixed and moveable knives if necessary.</li> <li>●機針是否過粗? Is the needle too wide?</li> <li>◎使用比現有機針小一號的機針 Try using a needle with a count that is one lower than the current needle.</li> <li>●縫紉開始時，縫紉速度是否過快? Is the sewing speed too fast at the sewing start?</li> <li>◎使用慢速起縫。 Use the slow start feature</li> </ul>
16.	縫線不平整 Uneven Seam 	<ul style="list-style-type: none"> <li>●壓具壓力是否過小? Is the presser foot pressure too weak?</li> <li>◎調整壓具壓力。 Adjust the presser foot pressure.</li> <li>●送布牙高度是否太低? Is the feed dog too low?</li> <li>◎調整送布牙高度。 Adjust the feed dog height.</li> </ul>
17.	大量的縐褶（張力過大） Large Degree of Puckering (Excess Tension) 	<ul style="list-style-type: none"> <li>●針線張力是否過大? Is the upper thread tension too strong?</li> <li>◎盡量減小針線張力。 Make the upper thread tension as weak as possible.</li> <li>●勾針線張力是否過大? Is the looper thread tension too strong?</li> <li>◎盡量減小勾針線張力。 Make the looper thread tension as weak as possible.</li> <li>●挑線簧張力是否過大? Are the thread take-up spring tensions too strong?</li> <li>◎盡量減小挑線簧張力。 Make the thread take-up spring tension as weak as possible.</li> </ul>

No.	現象 Problem	檢查及調整 Exam and Adjustment
17.	大量的縐褶（張力過大） Large Degree of Puckering (Excess Tension)	<ul style="list-style-type: none"> <li>●挑線簧活動範圍是否過大? Is the thread take-up spring operating range too large?</li> <li>◎盡量降低挑線簧位置。 Lower the thread take-up spring as low as possible.</li> <li>●壓具壓力是否過大? Is the presser foot pressure too strong?</li> <li>◎調整壓具壓力。 Adjust the presser foot pressure.</li> <li>●縫紉速度是否過快? Is the sewing speed too fast?</li> <li>◎減低縫紉速度。 Use the sewing speed control keys to gradually reduce the sewing speed.</li> </ul>
18.	打開電源並踩下腳踏板時，縫紉機不動作。 Machine Does Not Operate When Power Is Turned On And Treadle Is Pressed.	<ul style="list-style-type: none"> <li>●電源插頭是否從控制箱上鬆開? Is the power supply connector disconnected from the control box?</li> <li>◎將插頭插牢。 Insert the connector securely.</li> </ul>
19.	縫紉機不能以高速運轉 Machine Does Not Operate At High Speed	<ul style="list-style-type: none"> <li>●縫紉速度設定和倒縫加固速度設定是否正確? Is the sewing speed setting or backtack speed setting incorrect?</li> <li>◎請設定在高速縫紉速度 Use the sewing speed control keys to set the high speed.</li> </ul>
20.	在縫紉過程中縫紉機停止運轉。 Machine stops during sewing.	<ul style="list-style-type: none"> <li>●定針鍵是否在ON位置? Is the fixed stitch key turned on?</li> <li>◎關閉定針鍵功能。 Turn off the function of fixed stitch key.</li> <li>●電源電壓是否太低? Is the power supply voltage too low?</li> <li>◎檢查電源。如果電線太長，或單一插座接入過多的電器，則可能造成電壓下降。 Check the power supply. (If the power cord is too long or too many appliances are being run from a single outlet, this may cause voltage drops.)</li> </ul>

圖表2/Chart 2



# TABLE CUT-OUT OF S007K-T1

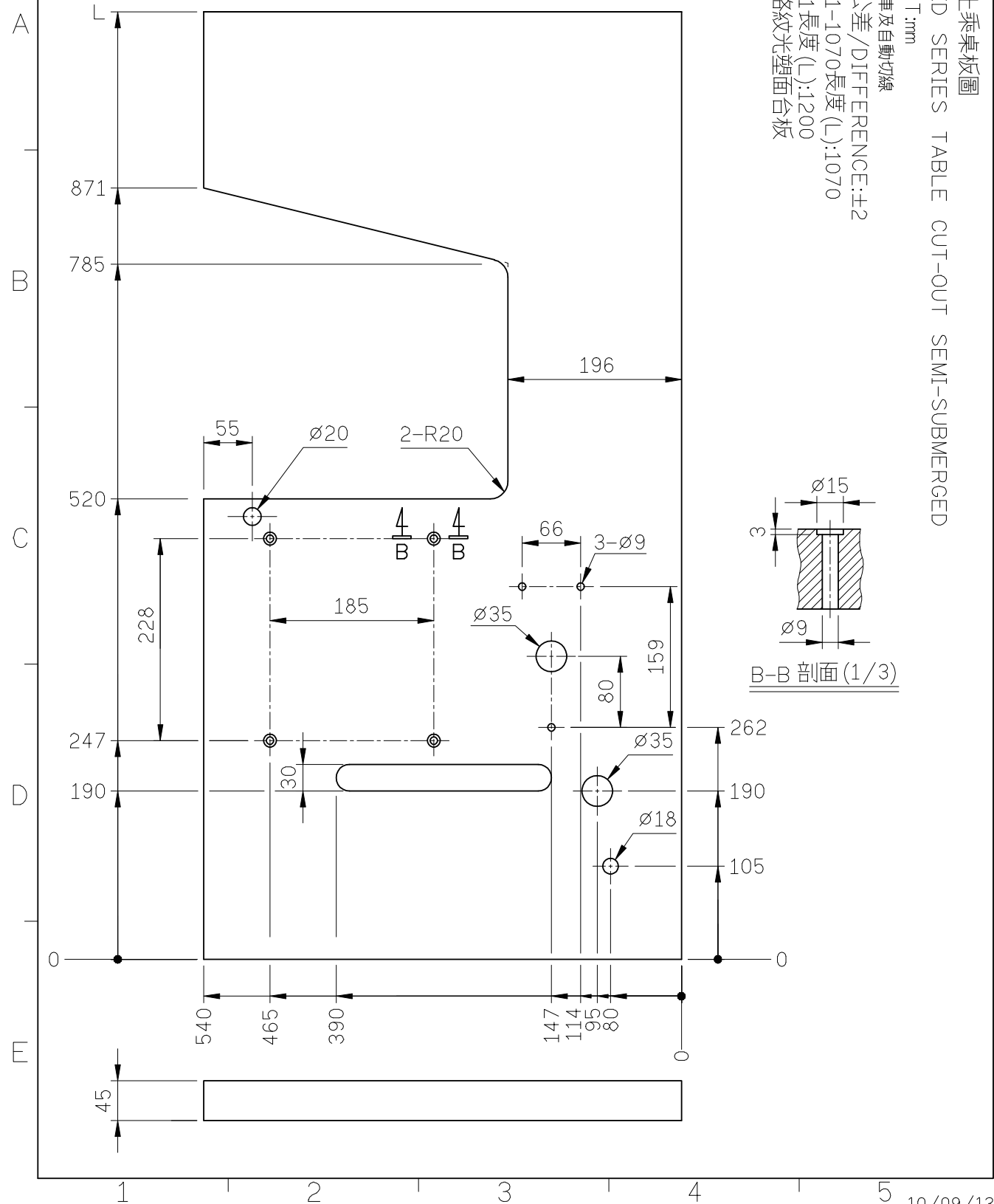

# TABLE CUT-OUT OF S007K-T2

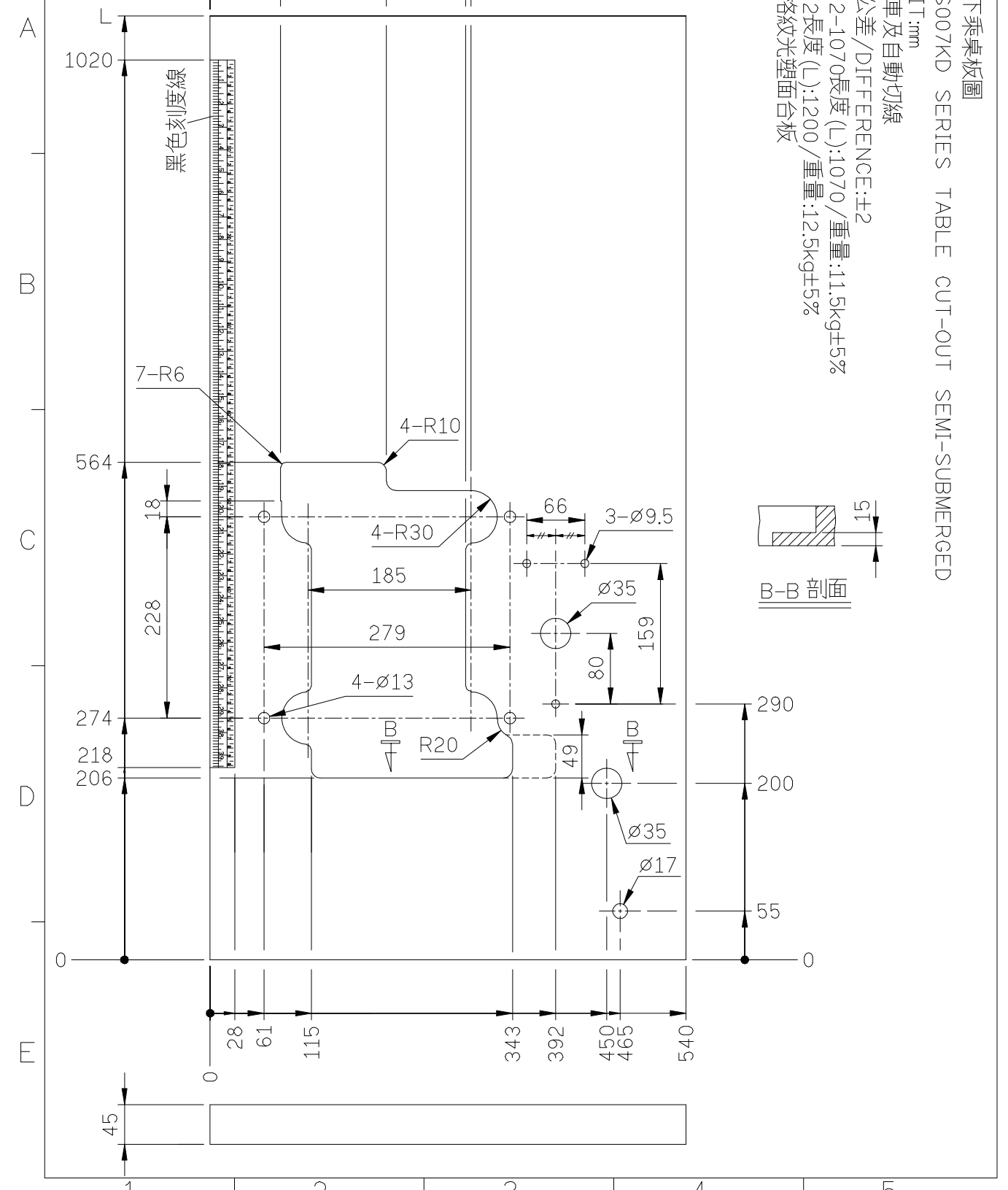





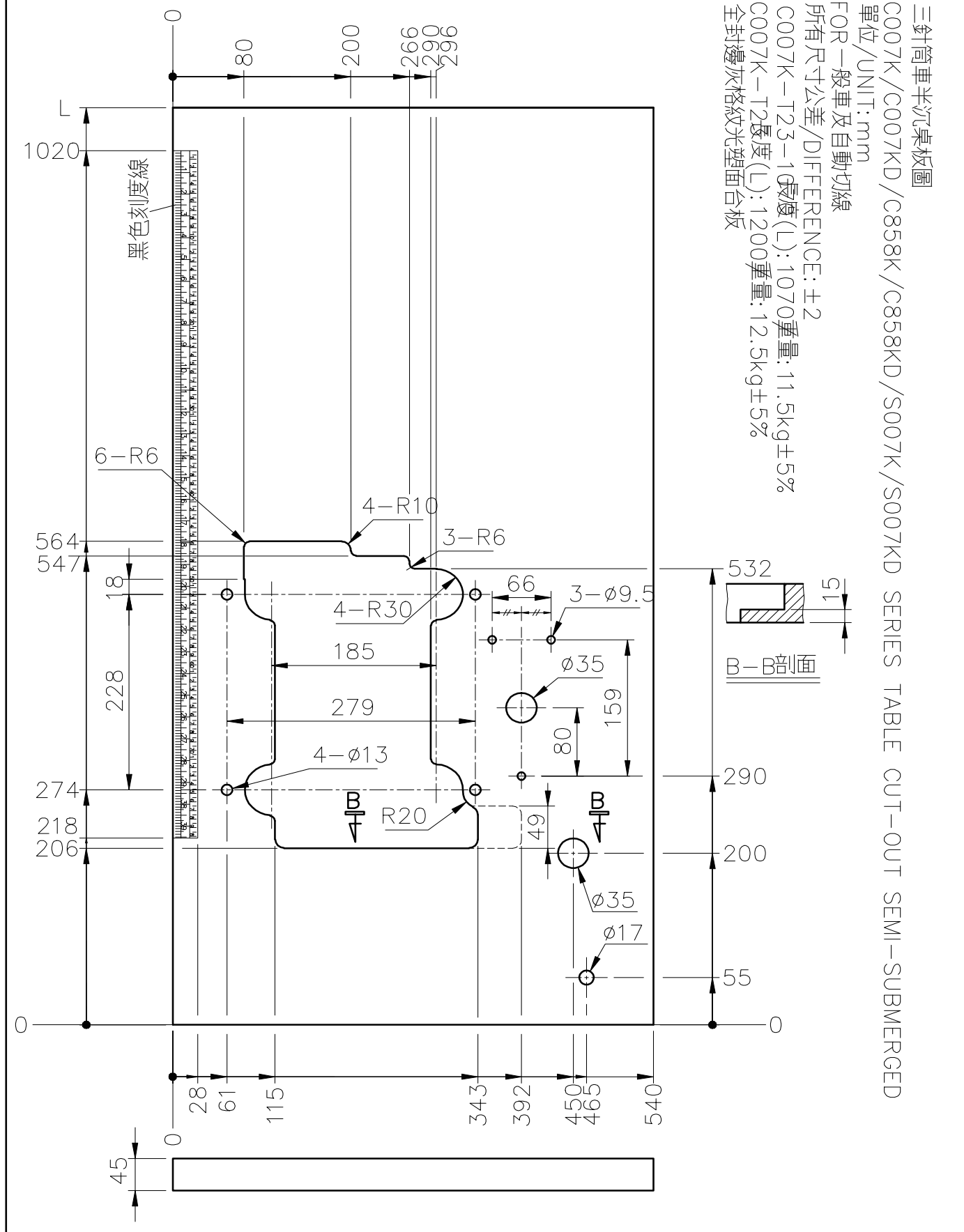

SIRUBA TABLE CUT - OUT	Series	Item Code	Subclass / Remark	Mounting
	C007K/C007KD C858K/C858KD S007K/S007KD	C007K-T23	For All Series	Semi-submerged
				Date
				2013/01/26

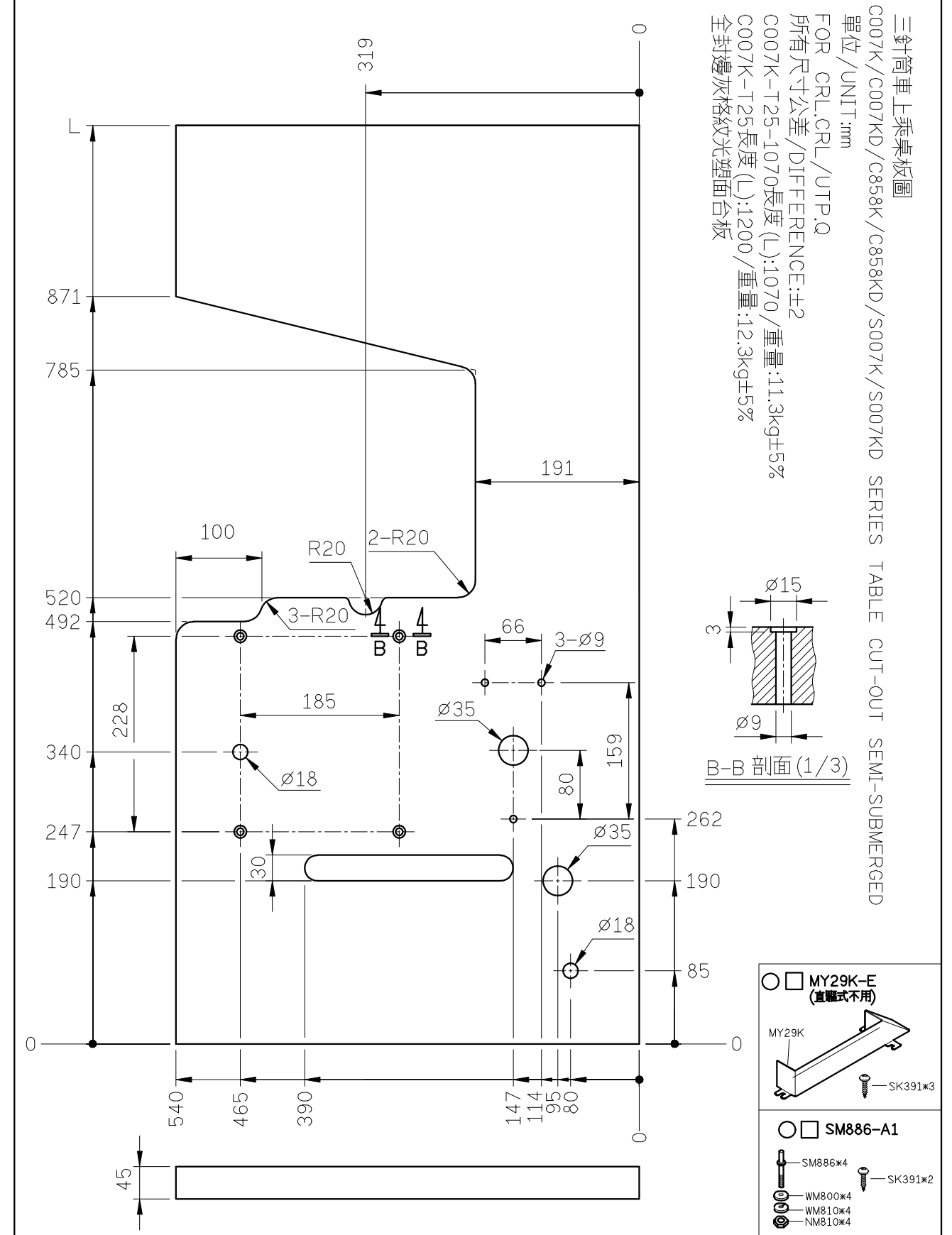

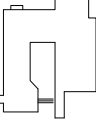
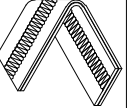
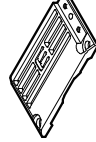
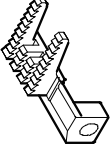
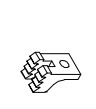
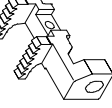
SIRUBA TABLE CUT - OUT	Series	Item Code	Subclass / Remark	Mounting
	C007K/C007KD C858K/C858KD S007K/S007KD	C007K-T25	For All Series excluding ① RLP,RLQ Celastic tape attaching ② CRL Models ③ Condensed stitch(CAR,CMR,SAR,SER...)	Non-submerged
				Date
				2013/01/26

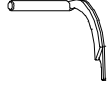

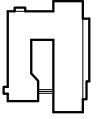
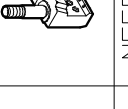
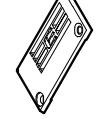
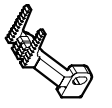
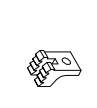
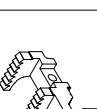
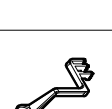
SIRUBA GAGE PARTS LIST		Series S007K / S007KD		Remark										Page 1 / 3	Date 2020/12/02	
	MODEL		NEEDLE CLAMP		NEEDLE PLATE		MAIN FEED DOG		DIFF. FEED DOG		PRESSER FOOT		LOOPER		LOOPER	NEEDLE
	機 型	規格	針 座	針 板	主 送 具	差 送 具	壓 具	上 送 具	壓 具	勾 針	上 叉	針 號				
W121/PCH-3M	240 248 356 364	M5240 M5248 M5356 M5364	E4094K E4095K E4096K E4097K	D4324K D4324K D4325K D4325K	H4387K H4387K H4379K H4379K	H4307K H4307K H4308K H4308K	P2674K-A P2674K-A P2576K-A P2576K-A	P2674K-A P2674K-A P2576K-A P2576K-A	MT01	MH41	UYX128GAS#10					
W122/PCH-3M	240 248 356 364	M5240 M5248 M5356 M5364	E3994K E3995K E3996K E3997K	D4324K D4324K D4325K D4325K	H4387K H4387K H4379K H4379K	H4307K H4307K H4308K H4308K	P2674K-A P2674K-A P2576K-A P2576K-A	P2674K-A P2674K-A P2576K-A P2576K-A	MT01	MH41	UYX128GAS#10					
W321/PCE	240 248 356 364	M5240 M5248 M5356 M5364	E4064K E4065K E4066K E4067K	D4324K D4324K D4325K D4325K	H4487K H4487K H4479K H4479K	H4307K H4307K H4308K H4308K	P2674K-A P2674K-A P2576K-A P2576K-A	P2674K-A P2674K-A P2576K-A P2576K-A	MT01	MH41	UYX128GAS#10					
W322/PCE	240 248 356 364	M5240 M5248 M5356 M5364	E3964K E3965K E3966K E3967K	D4324K D4324K D4325K D4325K	H4487K H4487K H4479K H4479K	H4307K H4307K H4308K H4308K	P2674K-A P2674K-A P2576K-A P2576K-A	P2674K-A P2674K-A P2576K-A P2576K-A	MT01	MH41	UYX128GAS#10					
U173/RF/UTT	100	M5356	E3996S	D4325S	H4308S	H4308S	P5356Q-A2	P5356Q-A2	MT01A	-	UYX128GAS#18					
W812/SRL/UTT	240 248	M5240 M5248	E3994RM E3995RM	D7240S	H7240S	H7240S	P2764-A P2765-A	P2764-A P2765-A	MT01	MH41	UYX128GAS#10					
W812A/SRL/UTT	240 248 356 364	M5240 M5248 M5356 M5364	E3994QM E3995QM E3996RM E3997RM	D7356S	H7356R	H7356R	P2764-A P2765-A P2766-A P2767-A	P2764-A P2765-A P2766-A P2767-A	MT01	MH41	UYX128GAS#10					

SIRUBA GAGE PARTS LIST		Series S007KD		Remark USE FOR FFT										Page 2 / 3	Date 2019/8/20				
	MODEL		NEEDLE CLAMP		NEEDLE PLATE		MAIN FEED DOG		DIFF. FEED DOG		TOP FEED DOG		PRESSER FOOT		LOOPER		SPREADER	NEEDLE	
	機 型	規格	針 座	針 板	主 送 具	差 送 具	上 送 具	壓 具	上 送 具	壓 具	上 送 具	壓 具	勾 針	上 叉	使用針				
W121/FFT/PCH	240 248 356 364	M5240 M5248 M5356 M5364	E4094K E4095K E4096K E4097K	E4094K E4095K E4096K E4097K	D4324K D4325K	H4387K H4379K	H4307K H4308K	H4387K H4379K	H4307K H4308K	F7240N F7356N	F7240N F7356N	P7240N-A P7248N-A P7356N-A P7364N-A	P7240N-A P7248N-A P7356N-A P7364N-A	MT01	MH41	UYX128GAS#10			
W121/FFT/PCH/UTT(UTX)	240 248 356 364	M5240 M5248 M5356 M5364	E4094K E4095K E4096K E4097K	E4094K E4095K E4096K E4097K	D4324K D4325K	H4387K H4379K	H4307K H4308K	H4387K H4379K	H4307K H4308K	F7240N F7356N	F7240N F7356N	P7240N-A P7248N-A P7356N-A P7364N-A	P7240N-A P7248N-A P7356N-A P7364N-A	MT01	MH41	UYX128GAS#10			
W122/FFT/PCH	240 248 356 364	M5240 M5248 M5356 M5364	E3994K E3995K E3996K E3997K	E3994K E3995K E3996K E3997K	D4324K D4325K	H4387K H4379K	H4307K H4308K	H4387K H4379K	H4307K H4308K	F7240N F7356N	F7240N F7356N	P7240N-A P7248N-A P7356N-A P7364N-A	P7240N-A P7248N-A P7356N-A P7364N-A	MT01	MH41	UYX128GAS#10			
W122/FFT/PCH/UTT(UTX)	240 248 356 364	M5240 M5248 M5356 M5364	E3994K E3995K E3996K E3997K	E3994K E3995K E3996K E3997K	D4324K D4325K	H4387K H4379K	H4307K H4308K	H4387K H4379K	H4307K H4308K	F7240N F7356N	F7240N F7356N	P7240N-A P7248N-A P7356N-A P7364N-A	P7240N-A P7248N-A P7356N-A P7364N-A	MT01	MH41	UYX128GAS#10			





SIRUBA PARTS LIST	Series	Parts Group	Subclass / Remark	Page
	S007K/S007KD	MG-K		1/1
	U007			Date
				2020/4/23

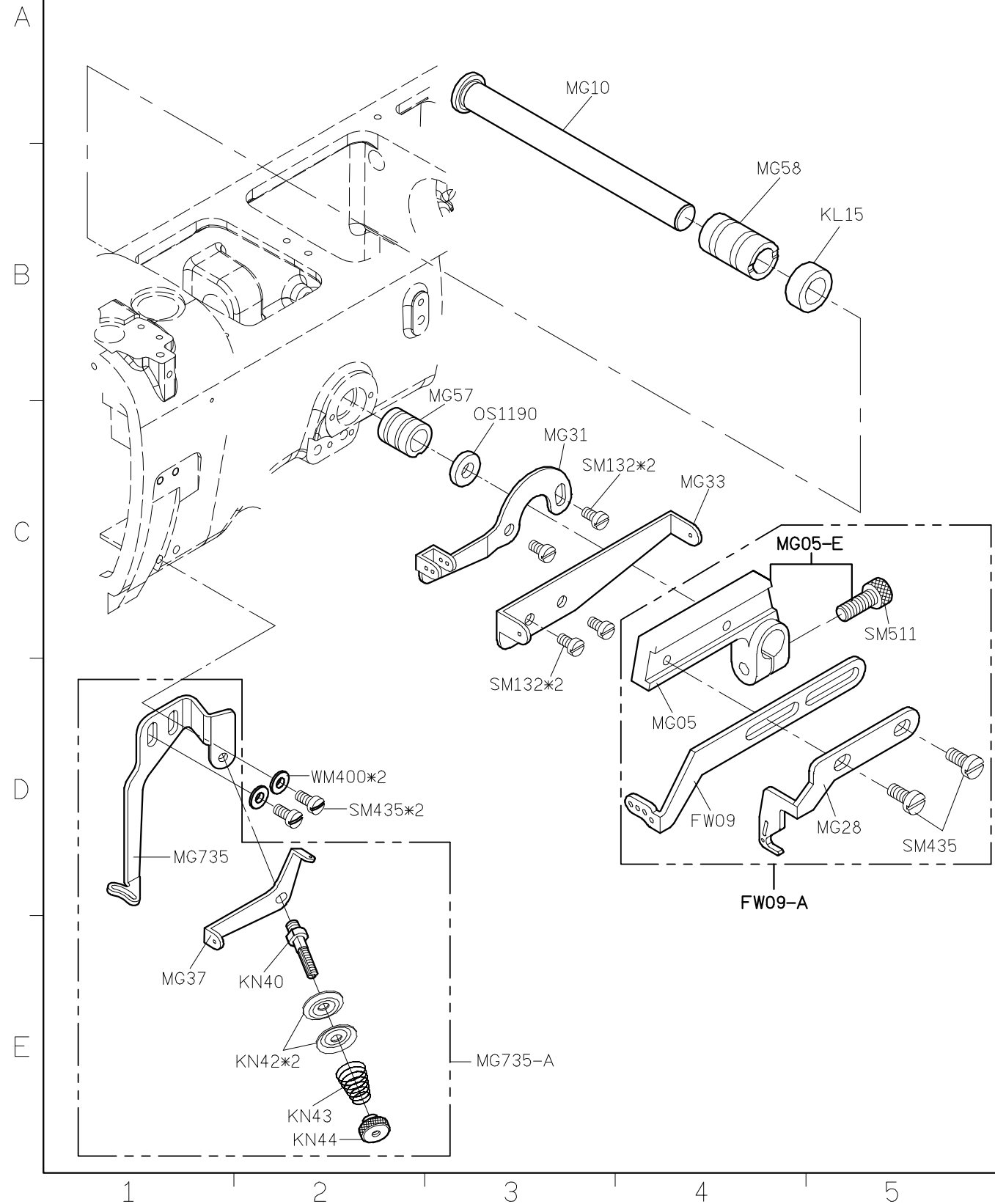

SIRUBA PARTS LIST	Series	Parts Group	Subclass / Remark	Page
	S007K/S007KD	MH-K	For S007K/S007KD 2 <sup>nd</sup> Generation	1/1
				Date
				2019/9/16

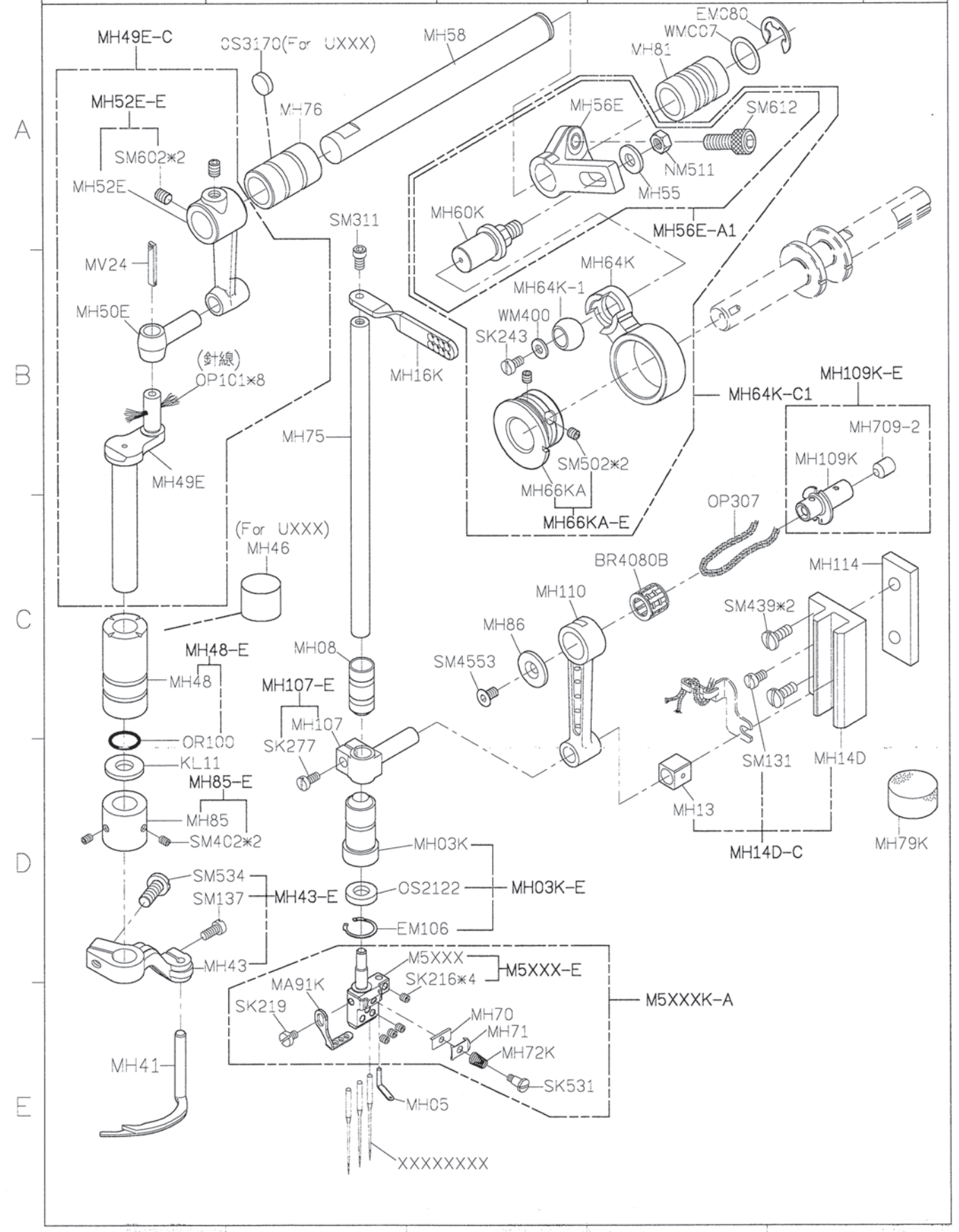

SIRUBA		Series	Parts Group	Subclass / Remark	Page
PARTS LIST		S007K/S007KD U007	MJ-K	For S007K/S007KD 2 <sup>nd</sup> Generation	1/1
					Date
					2020/11/24

組件代號	零件內容
MJ35K-A1	MJ35K/MJ38/NM610 MJ54K/SM492
MJ35K-A3	MJ35K/MJ38/NM610

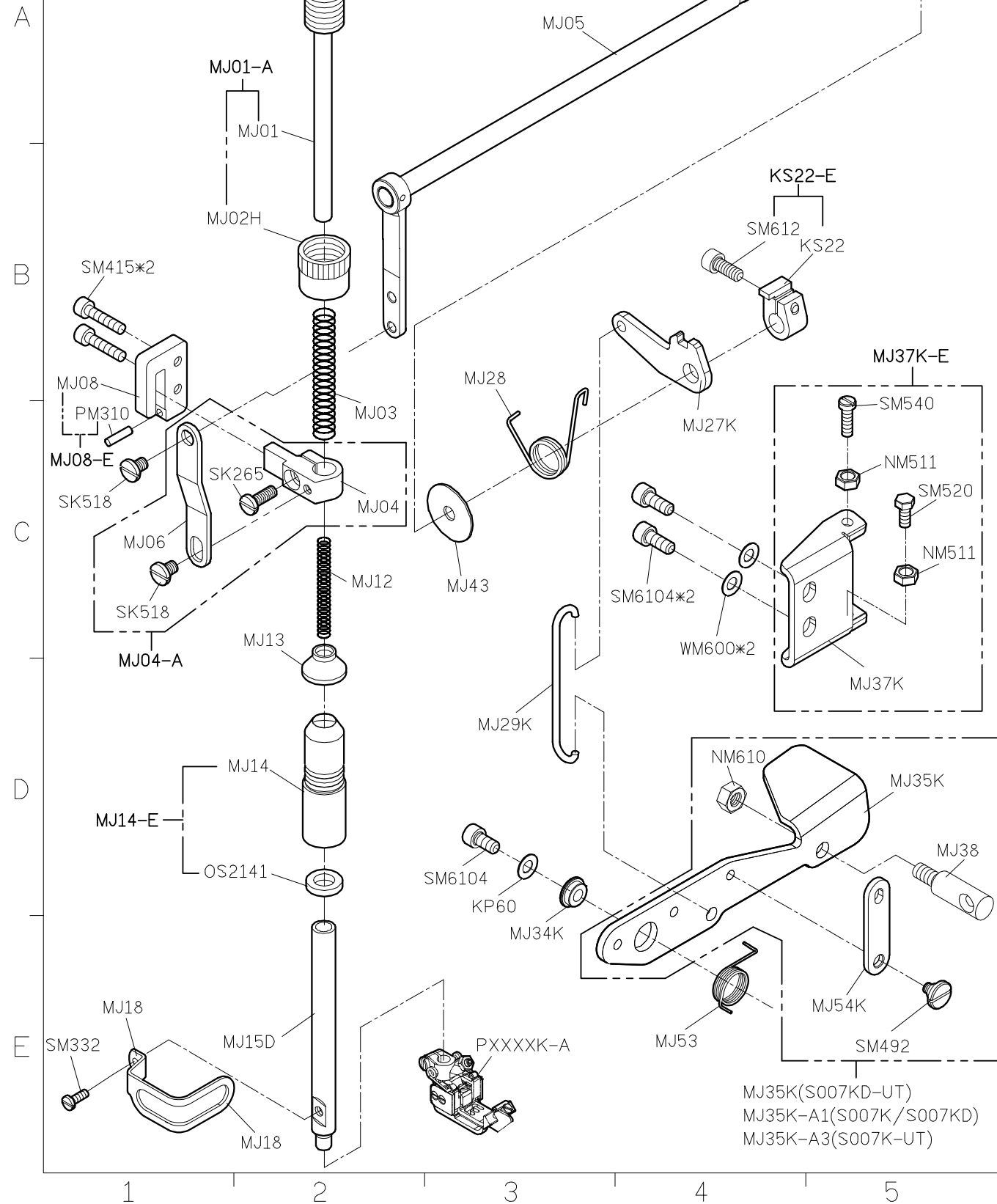

SIRUBA		Series	Parts Group	Subclass / Remark	Page
PARTS LIST		S007K/S007KD S007KP/U007	MK-K	For S007K/S007KD 2 <sup>nd</sup> Generation *:Use for S007KP	1/1
					Date
					2020/3/20

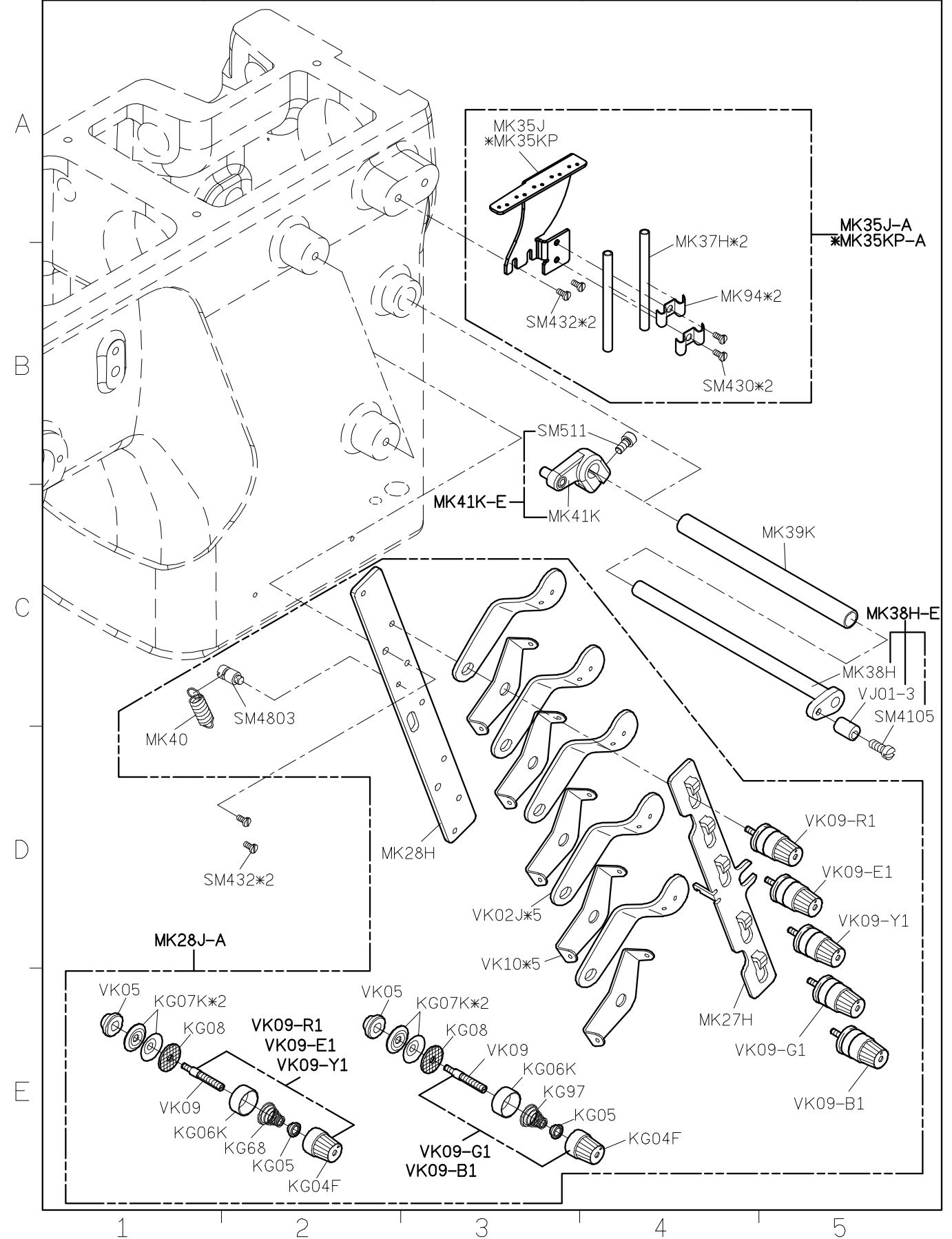

SIRUBA PARTS LIST	Series	Parts Group	Subclass / Remark	Page
	S007K/S007KD S007KP	MN-K	For S007K 2 <sup>nd</sup> Generation	1/3
				Date
				2019/08/08

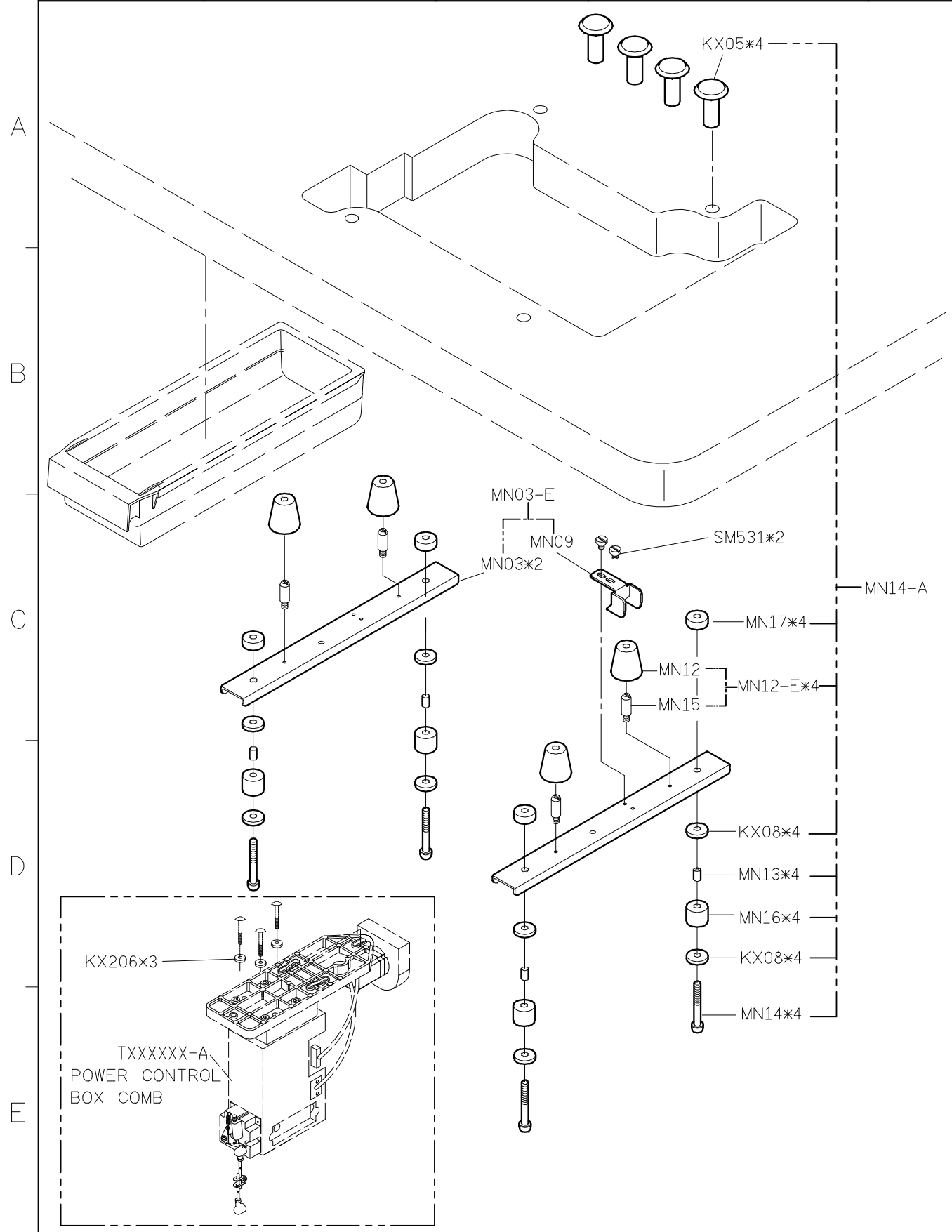

SIRUBA PARTS LIST	Series	Parts Group	Subclass / Remark	Page
	S007K/S007KD S007KP	MN-K	For S007K 2 <sup>nd</sup> Generation # Use for S007K	2/3
				Date
				2019/08/08

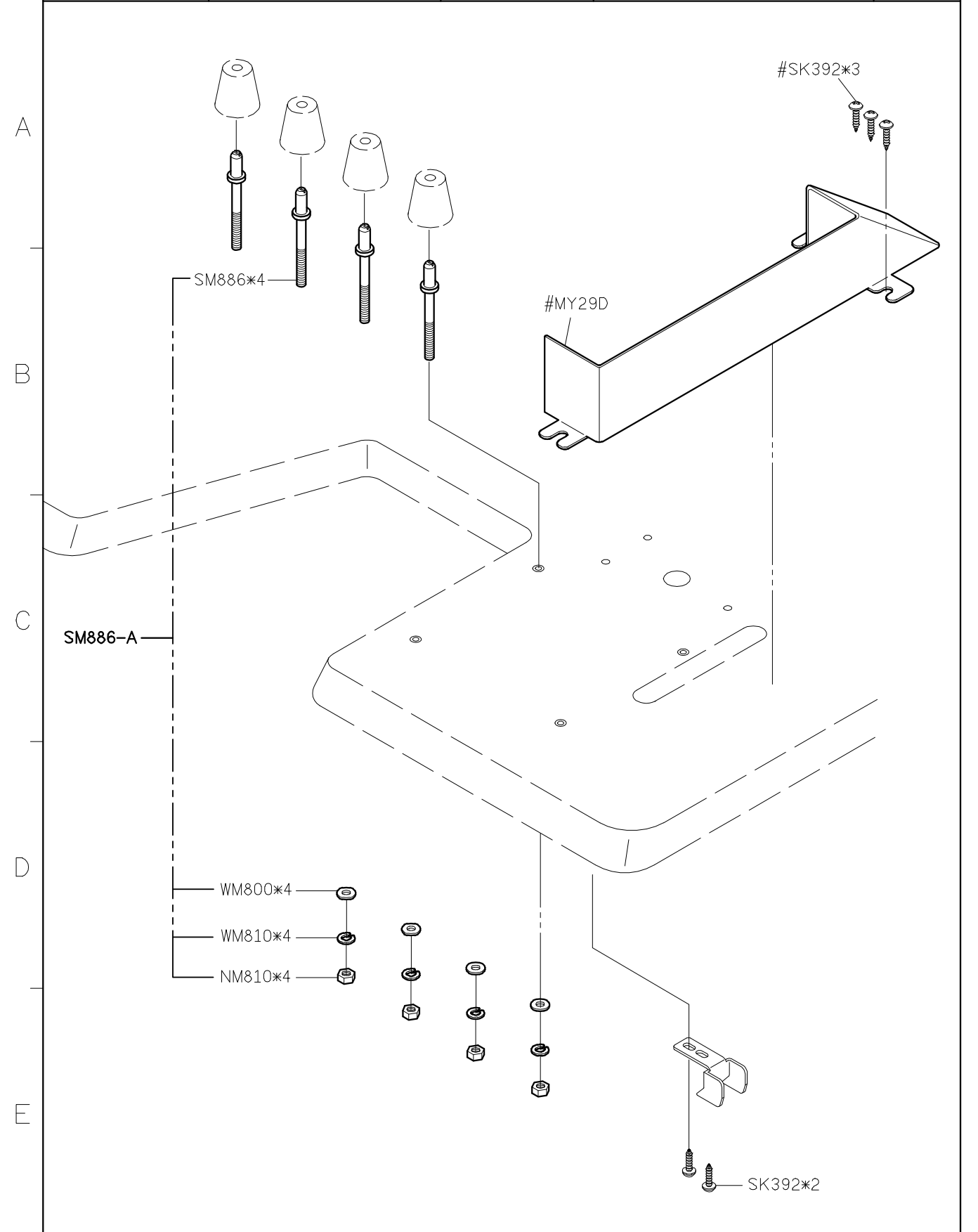



SIRUBA PARTS LIST	Series	Parts Group	Subclass / Remark	Page
	S007KP	MN-K	*Use For Direct-Drive Motor (P機/U機)	3/3
				Date
				2019/09/18

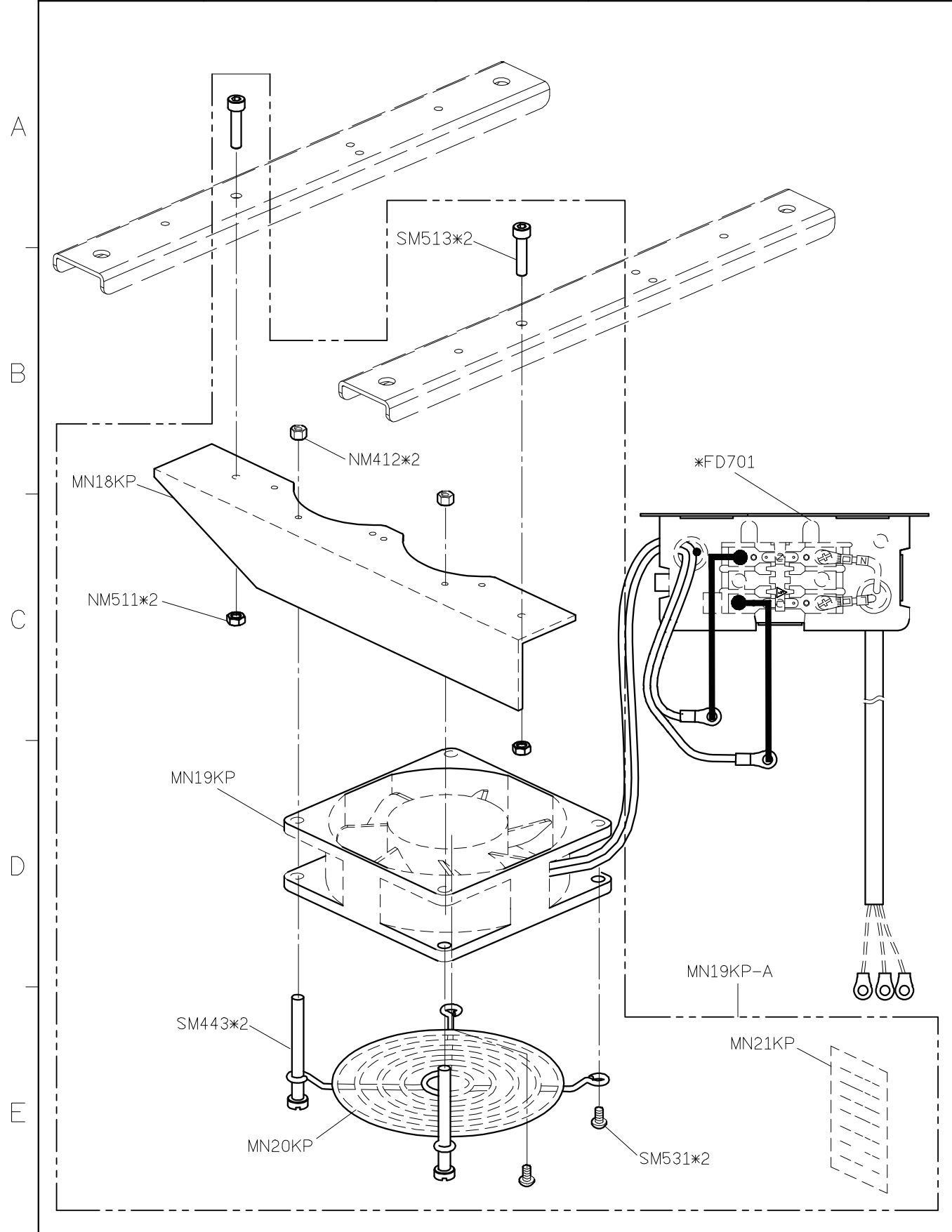

SIRUBA PARTS LIST	Series	Parts Group	Subclass / Remark	Page
	S007K/S007KD	SL-K	For S007K/S007KD 2 <sup>nd</sup> Generation	1/1
				Date
				2020/9/2

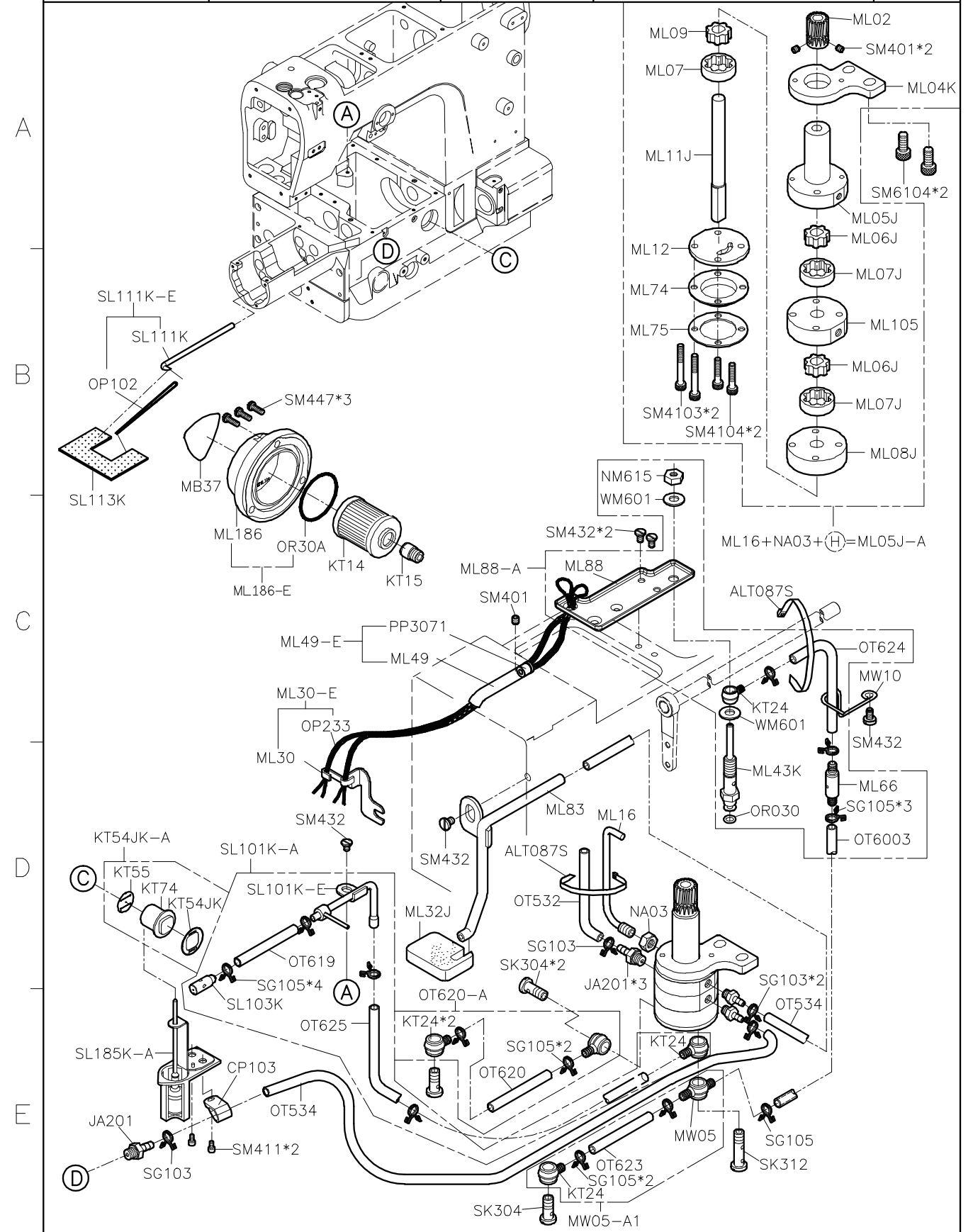

<b>SIRUBA</b> PARTS LIST	Series	Parts Group	Subclass / Remark	Page
	S007K/S007KD	<b>SQ-K</b>	For S007K/S007KD 2 <sup>nd</sup> Generation #: use for S007K	1/1
				Date
				2016/8/24

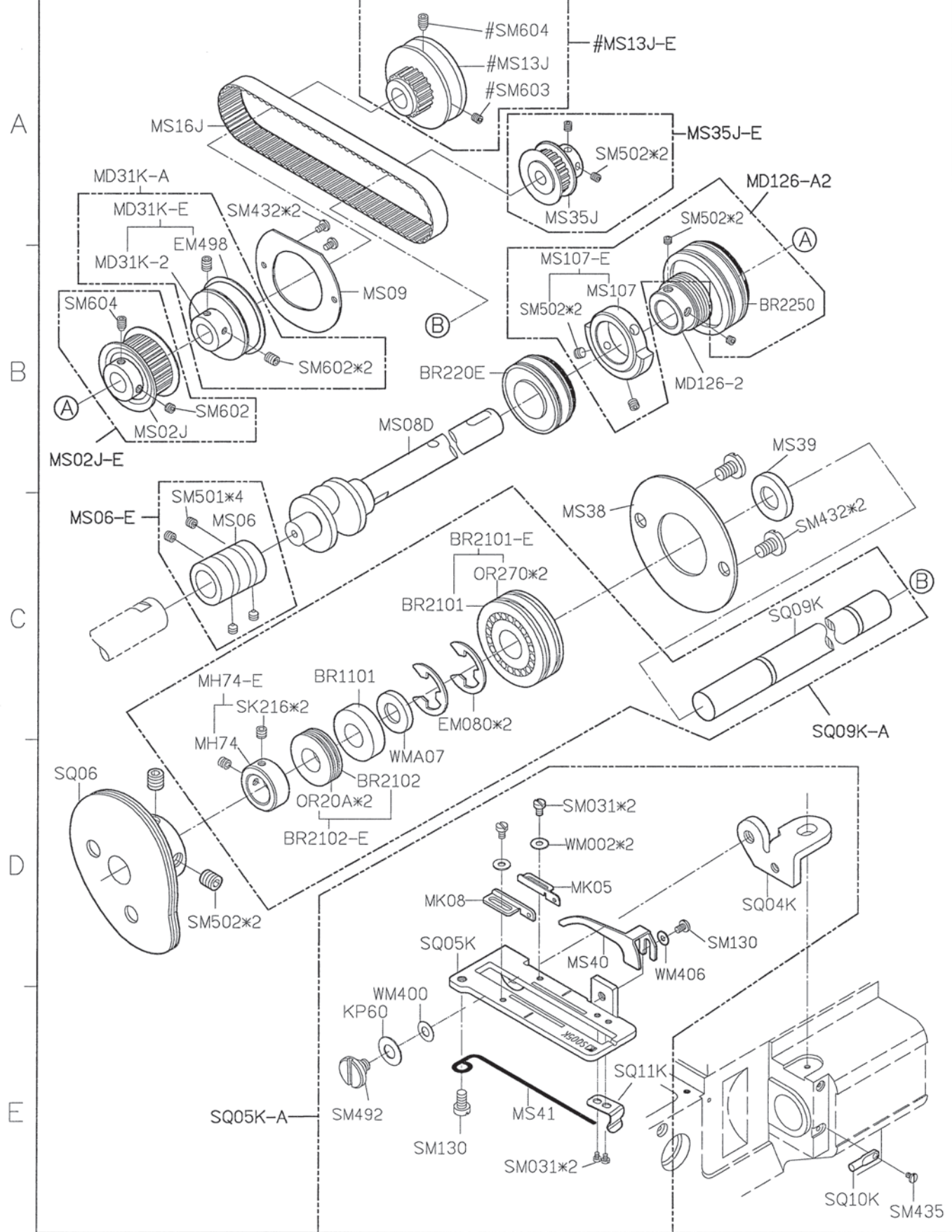

<b>SIRUBA</b> PARTS LIST	Series	Parts Group	Subclass / Remark	Page
	S007K/S007KD	<b>SR-K</b>	For S007K/S007KD 2 <sup>nd</sup> Generation #: use for S007K Δ: use for SW	1/6
				Date
				2020/4/13

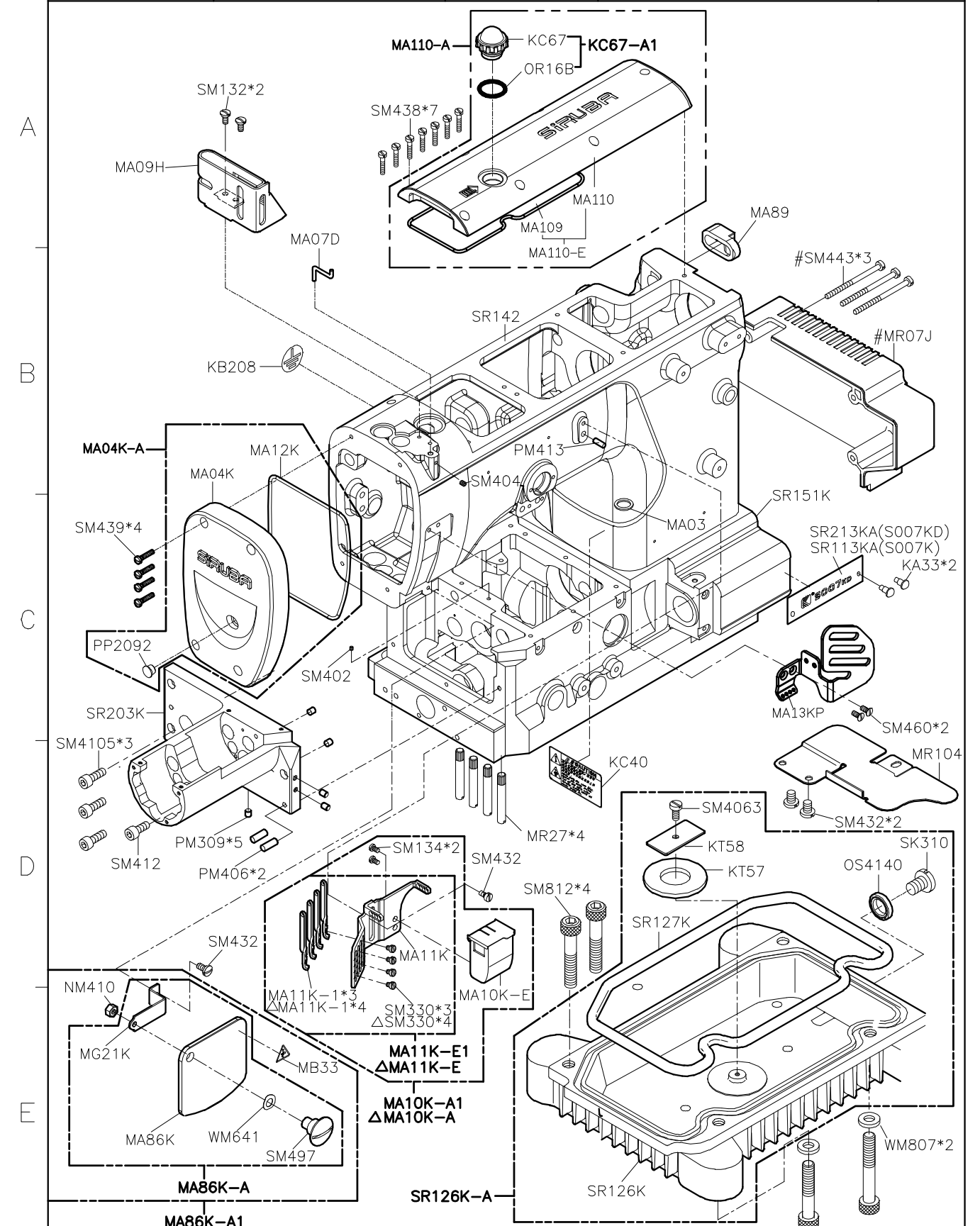



<b>SIRUBA</b> PARTS LIST	Series	Parts Group	Subclass / Remark	Page
	S007K/S007KD	<b>SR-K</b>	For S007K/S007KD 2 <sup>nd</sup> Generation	2/6
				Date
				2020/3/12

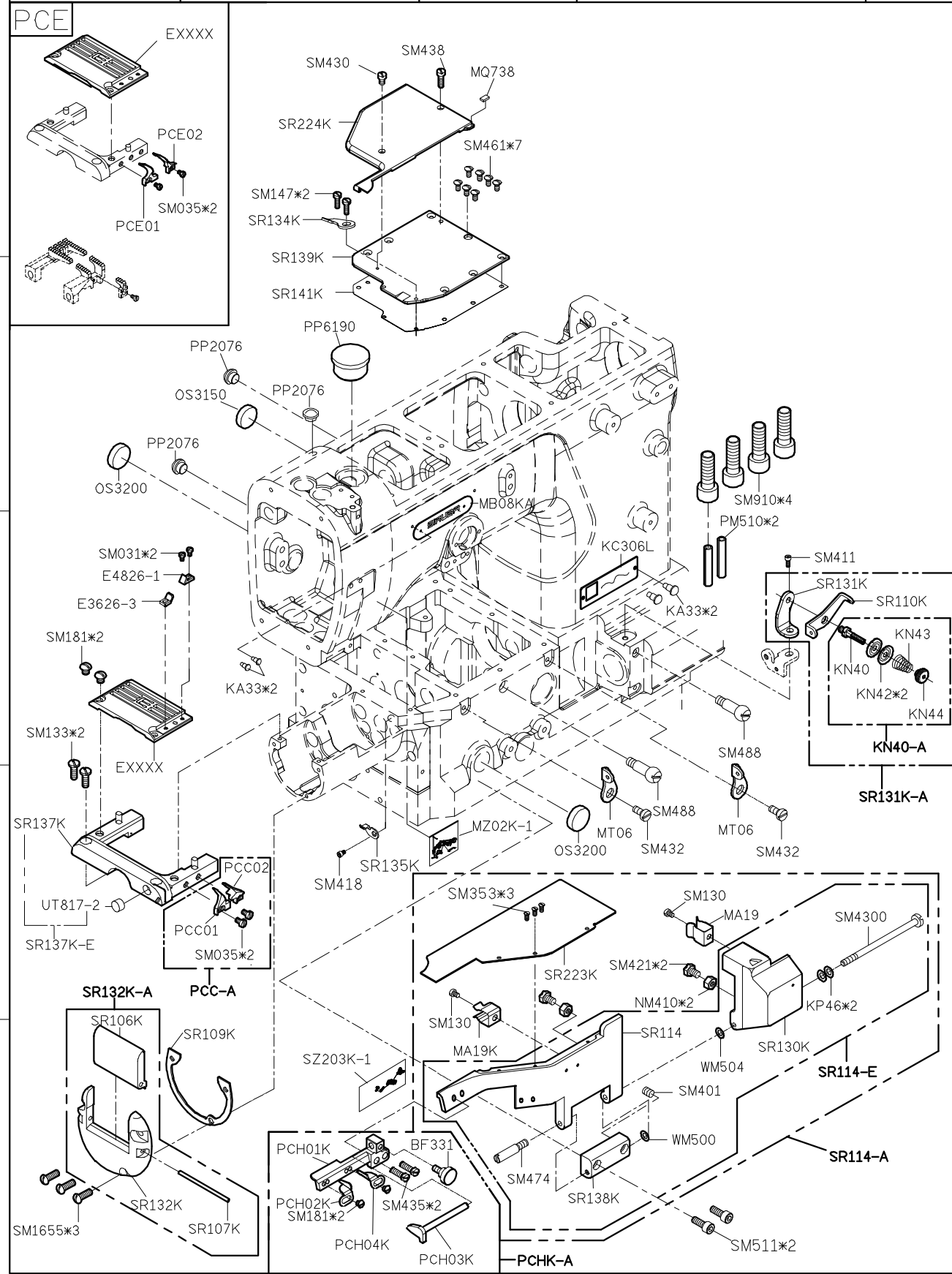

<b>SIRUBA</b> PARTS LIST	Series	Parts Group	Subclass / Remark	Page
	S007KD/U007	<b>SR-K</b>	For S007K/S007KD 2 <sup>nd</sup> Generation For Direct-Drive Motor (H <sup>牌</sup> ) #For Pneumatic Automatic %For Electric Automatic	3/6
				Date
				2020/9/4

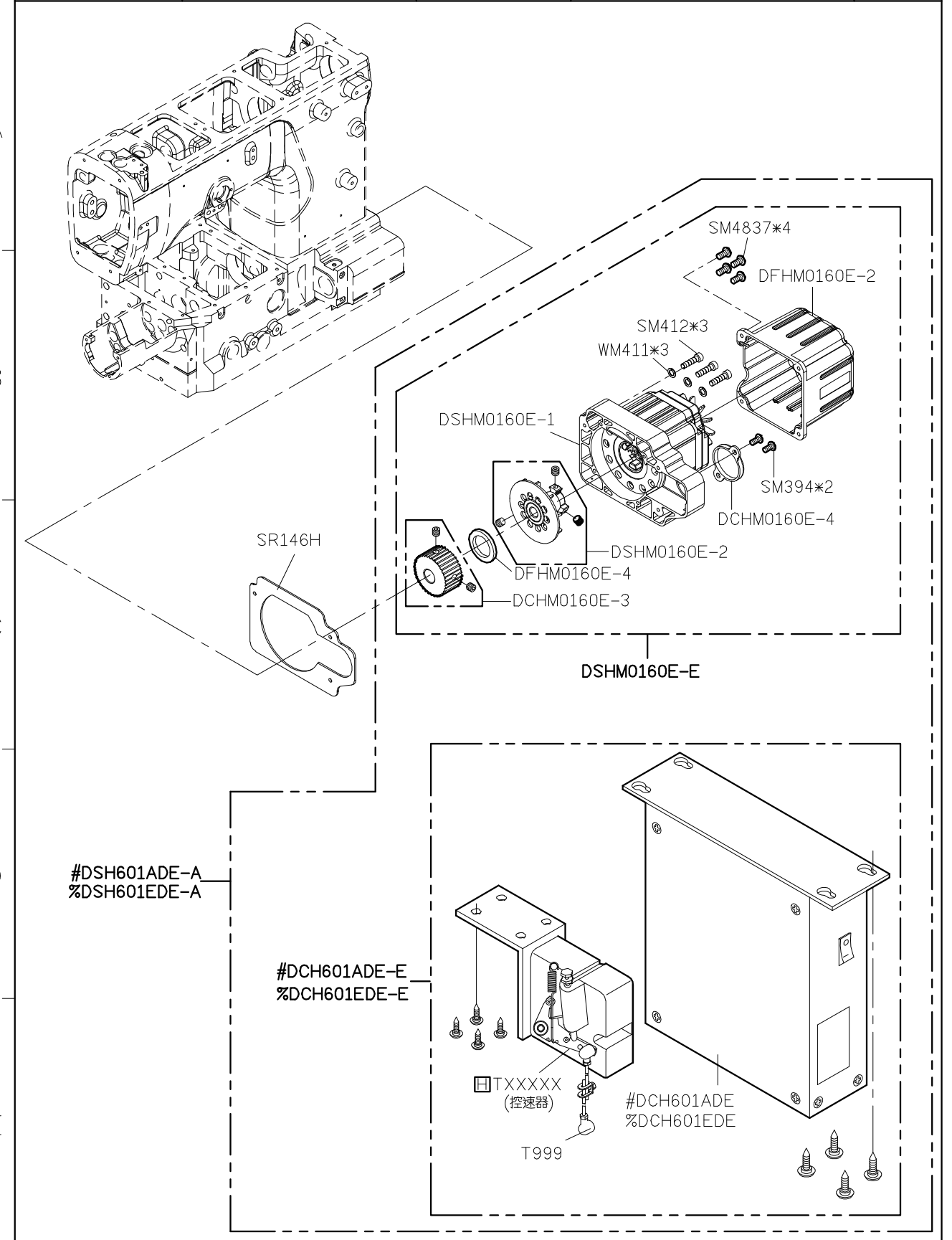

SIRUBA PARTS LIST	Series	Parts Group	Subclass / Remark	Page
	S007KD/U007	SR-K	For S007K/S007KD 2 <sup>nd</sup> Generation For Direct-Drive Motor ( T牌) #For Pneumatic Automatic %For Electric Automatic	4/6
				Date
				2019/8/02

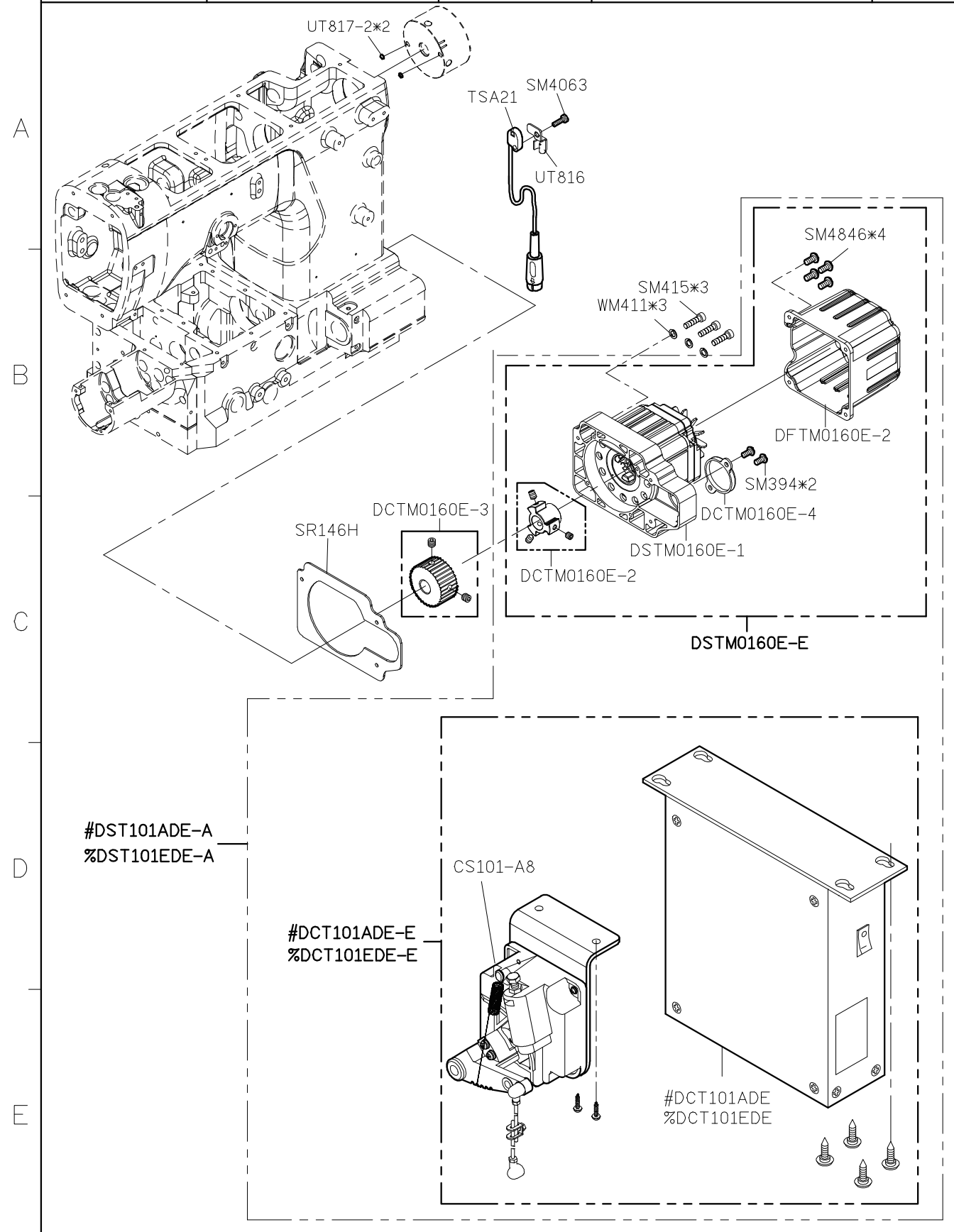

SIRUBA PARTS LIST	Series	Parts Group	Subclass / Remark	Page
	S007KD/U007	SR-K	For S007K/S007KD 2 <sup>nd</sup> Generation For Direct-Drive Motor ( P牌) #For Pneumatic Automatic %For Electric Automatic	5/6
				Date
				2020/9/4

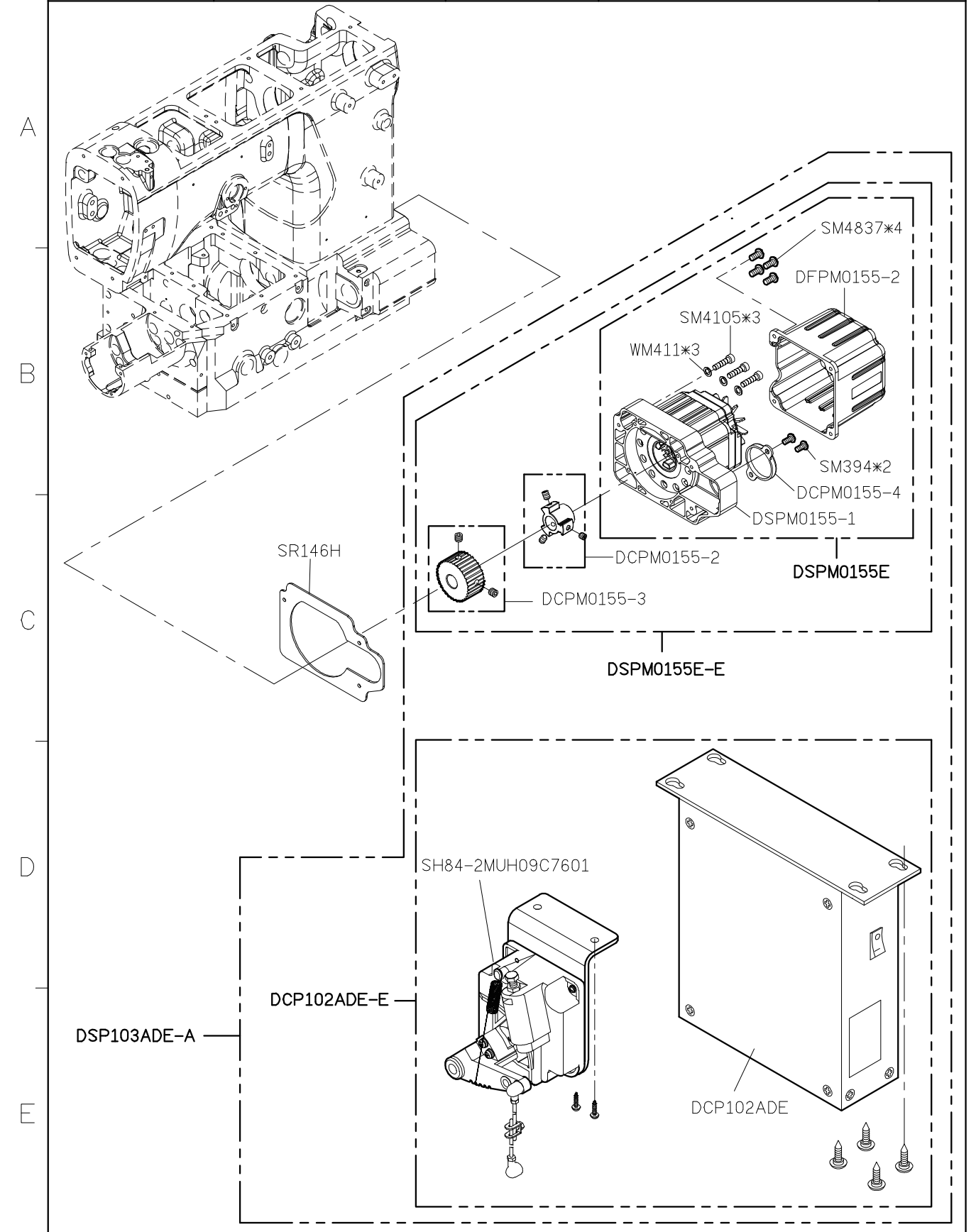



<b>SIRUBA</b> PARTS LIST	Series	Parts Group	Subclass / Remark	Page
	S007KD/U007	<b>SR-K</b>	For Direct-Drive Motor (U#)	6/6
				Date
				2019/8/02

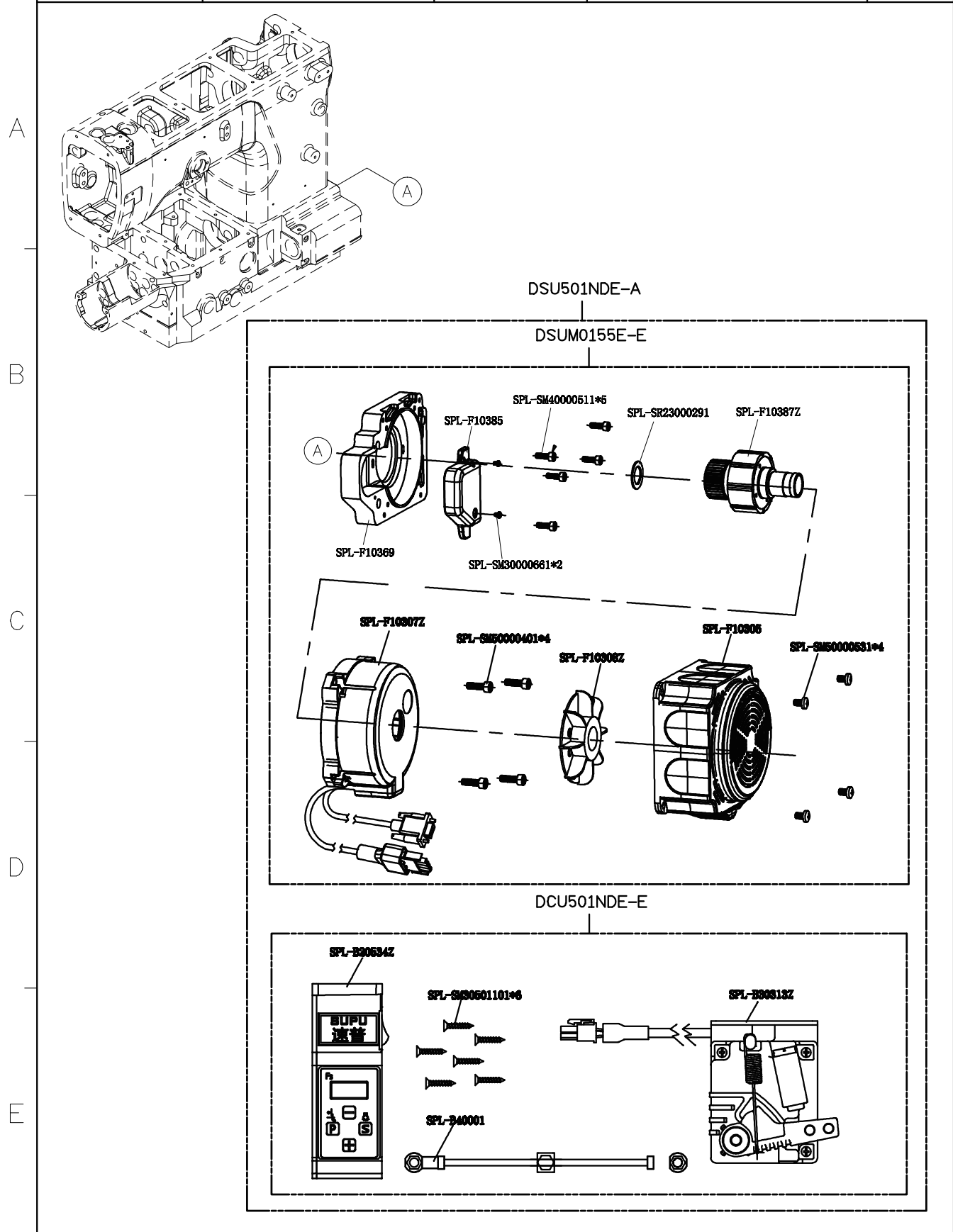

<b>SIRUBA</b> PARTS LIST	Series	Parts Group	Subclass / Remark	Page
	S007K/S007KD	<b>SS-K</b>	For S007K/S007KD 2 <sup>nd</sup> Generation	1/1
				Date
				2016/8/24

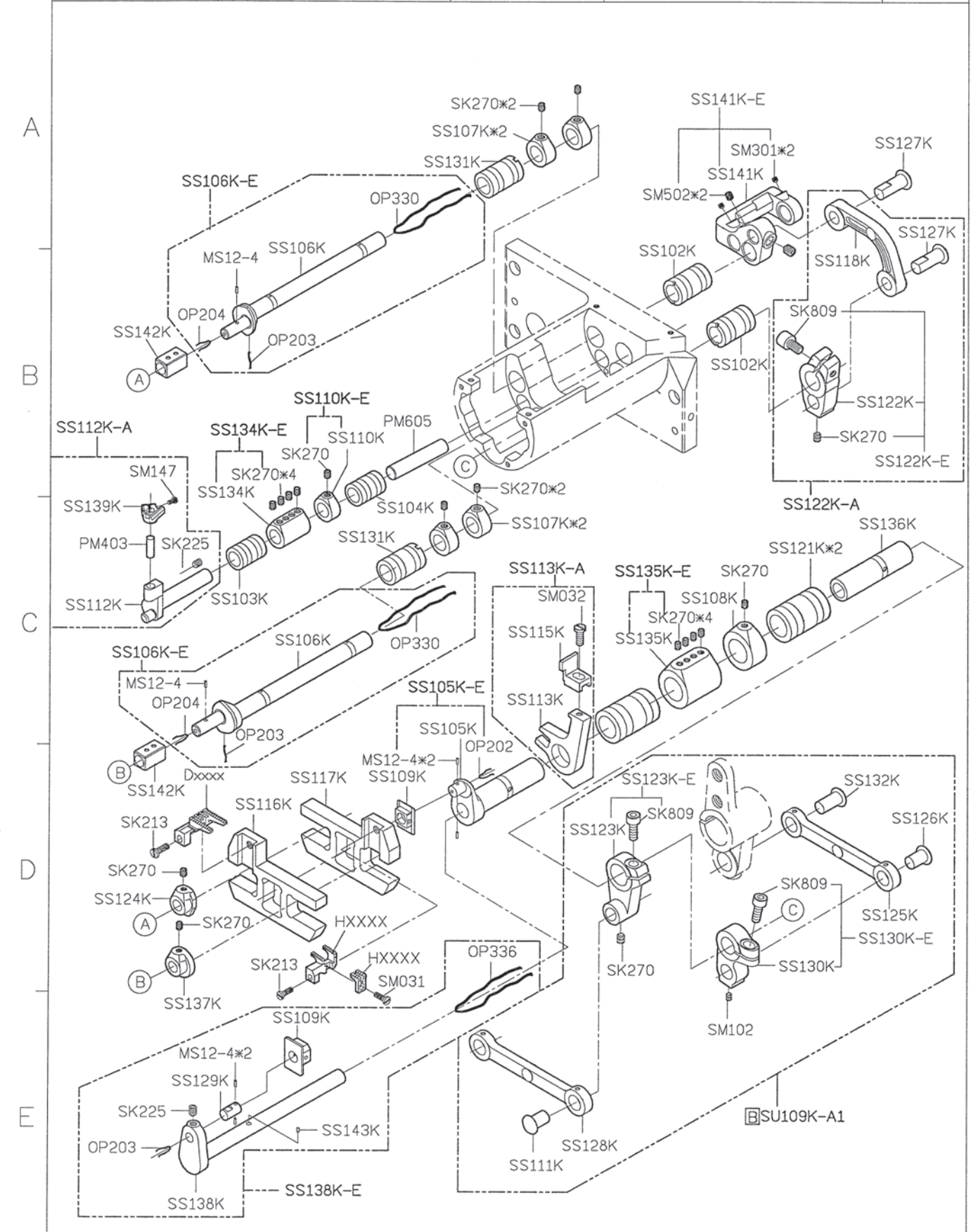

<b>SIRUBA</b> PARTS LIST	Series	Parts Group	Subclass / Remark	Page
	S007K/S007KD	<b>ST-K</b>	For S007K/S007KD 2 <sup>nd</sup> Generation	1/1
				Date
				2017/8/31

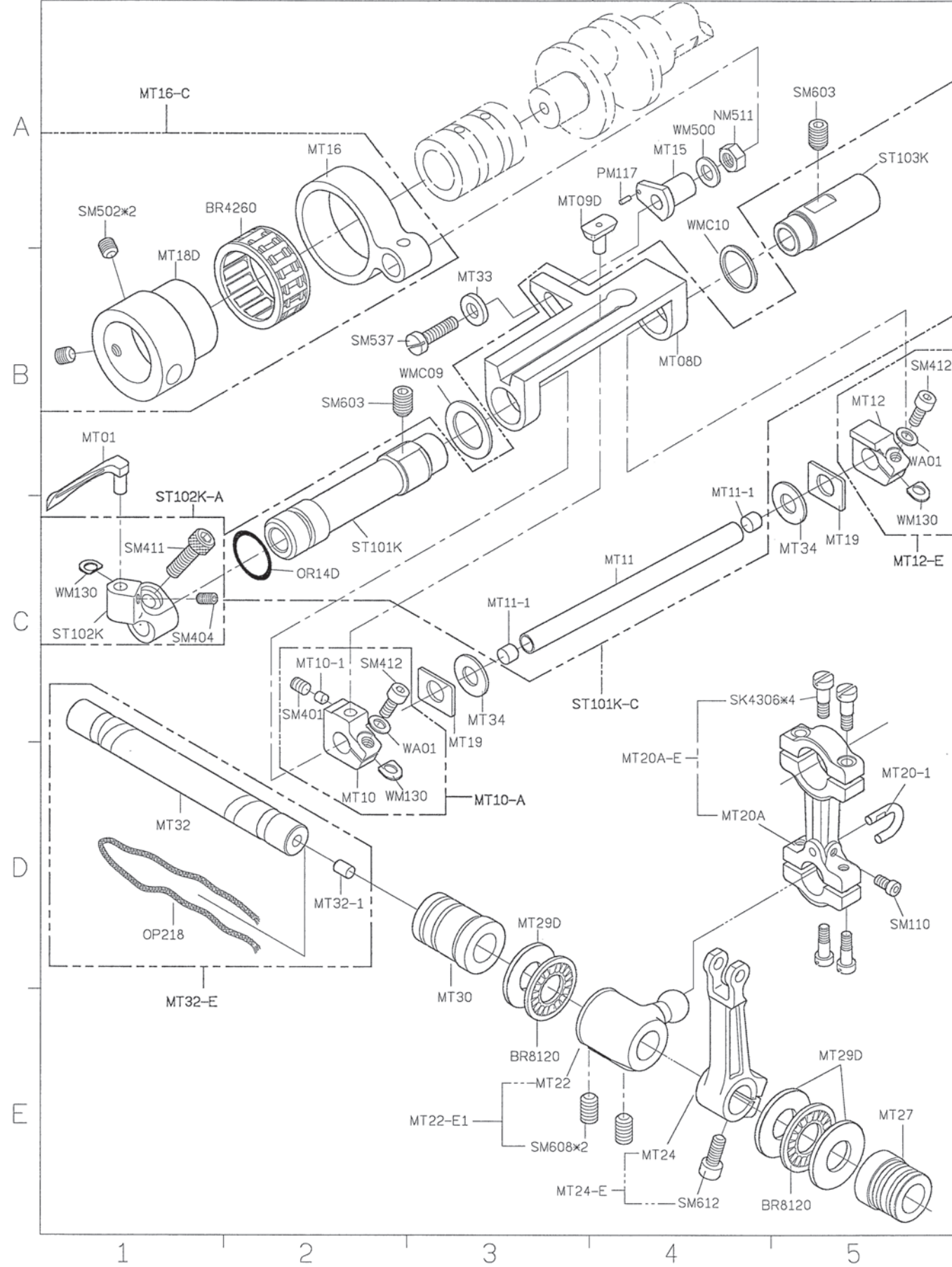

<b>SIRUBA</b> PARTS LIST	Series	Parts Group	Subclass / Remark	Page
	S007K/S007KD U007	<b>SU-K</b>	For S007K/S007KD 2 <sup>nd</sup> Generation	1/1
				Date
				2020/8/20

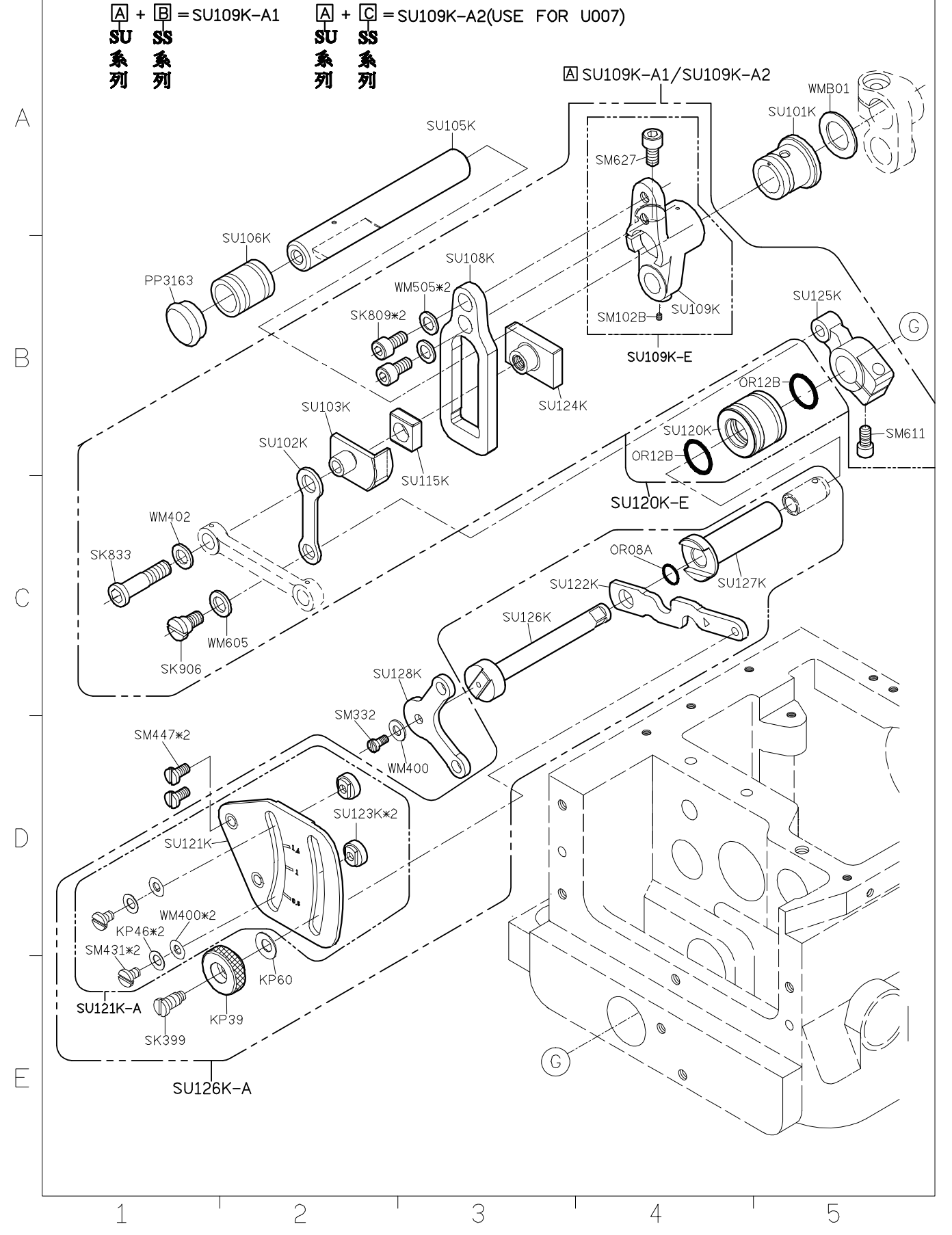



<b>SIRUBA</b> PARTS LIST	Series	Parts Group	Subclass / Remark	Page
	S007K/S007KD	<b>SV-K</b>	For S007K/S007KD 2 <sup>nd</sup> Generation	1/1
				Date
				2016/8/24

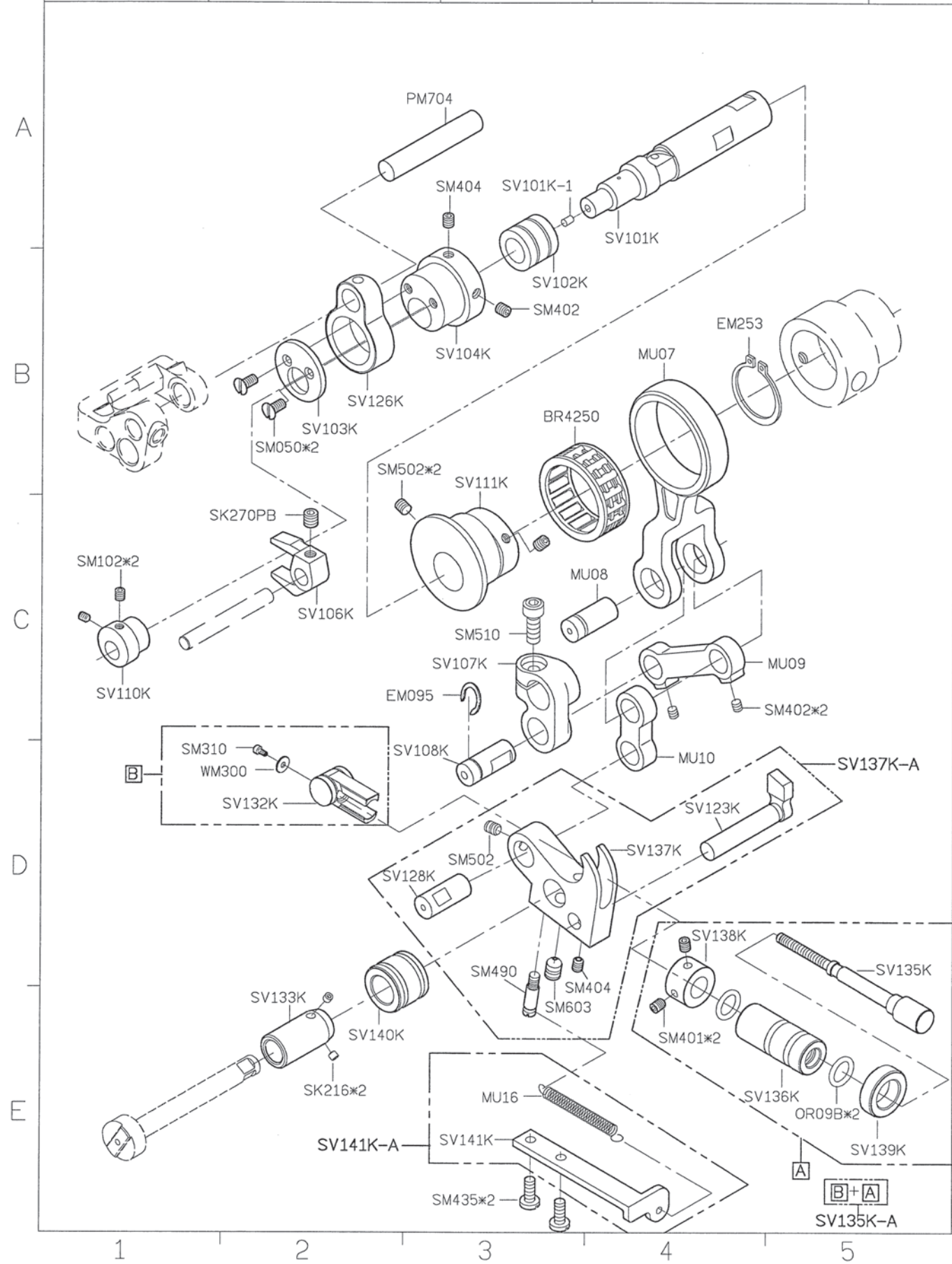

<b>SIRUBA</b> PARTS LIST	Series	Parts Group	Subclass / Remark	Page
	S007K/S007KD	<b>SY-K</b>	For S007K/S007KD 2 <sup>nd</sup> Generation	1/1
				Date
				2018/07/24

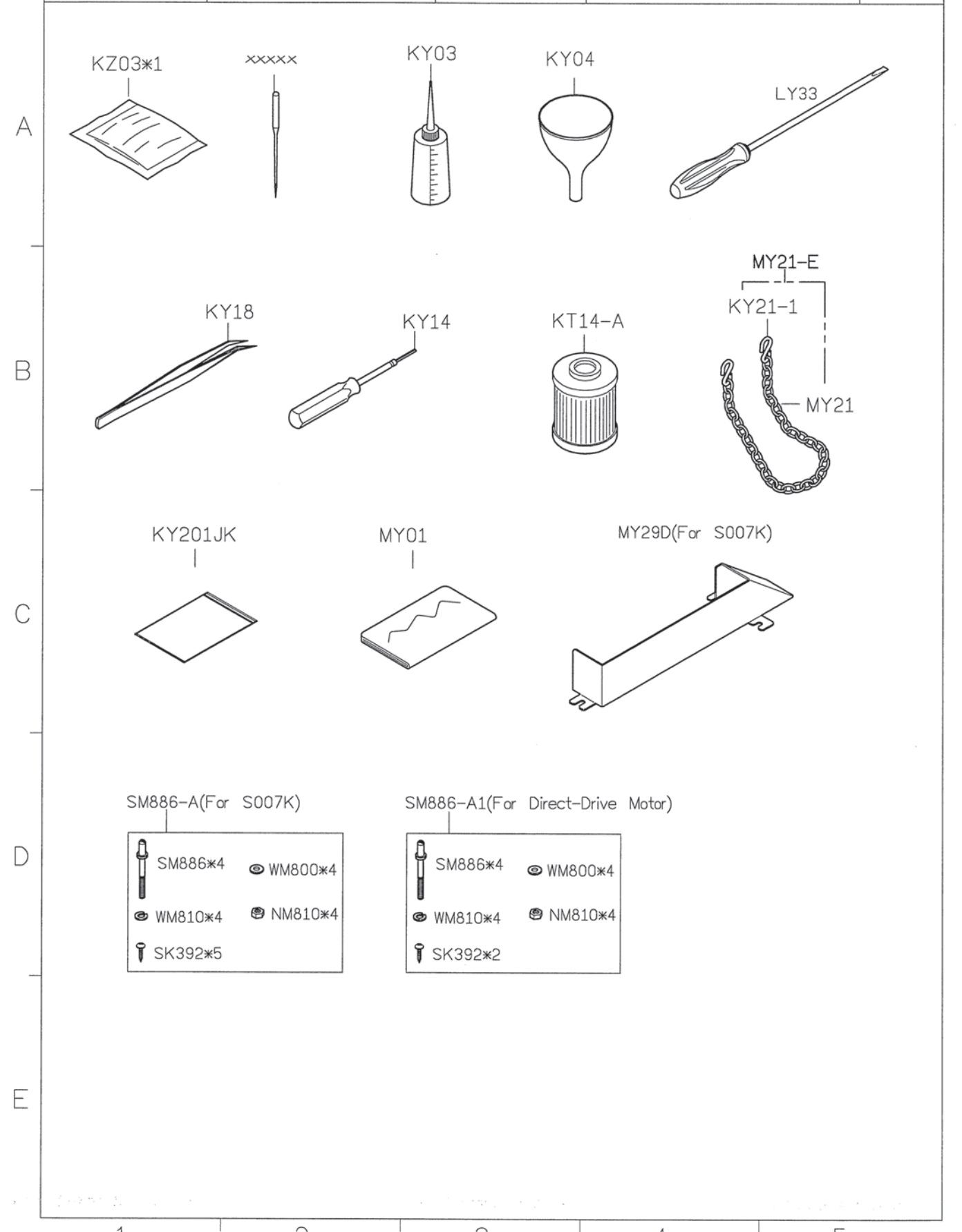



SIRUBA PARTS LIST	Series	Parts Group	Subclass / Remark	Page
	S007K	SZ-K	* : USE FOR S007KP	1/2
	S007KP			Date
				2019/06/12

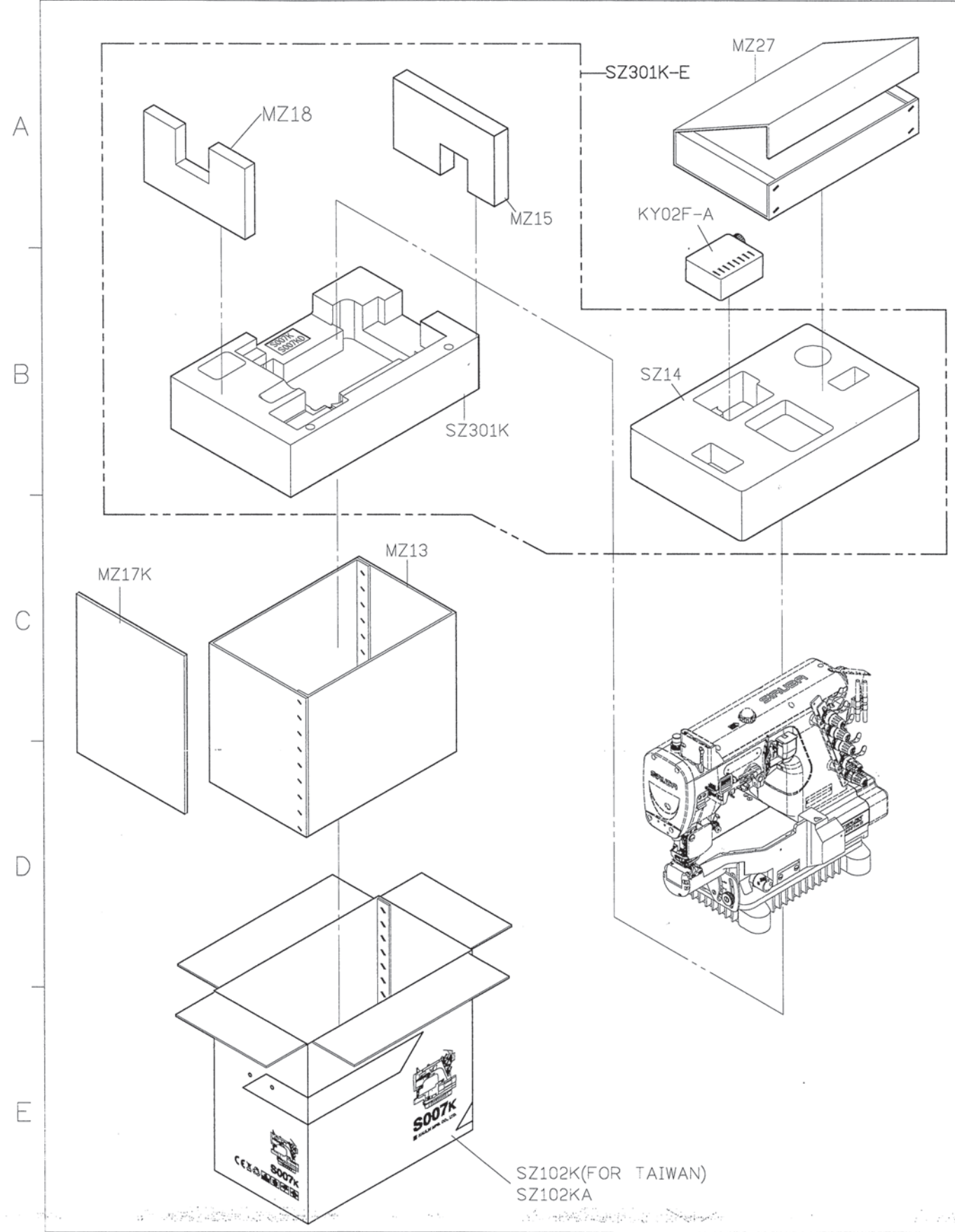

1 2 3 4 5

SIRUBA PARTS LIST	Series	Parts Group	Subclass / Remark	Page
	S007KD	SZ-K	@: Use for Drive Motor+UT * : USE FOR S007KP	2/2
	S007KP			Date
				2019/06/12

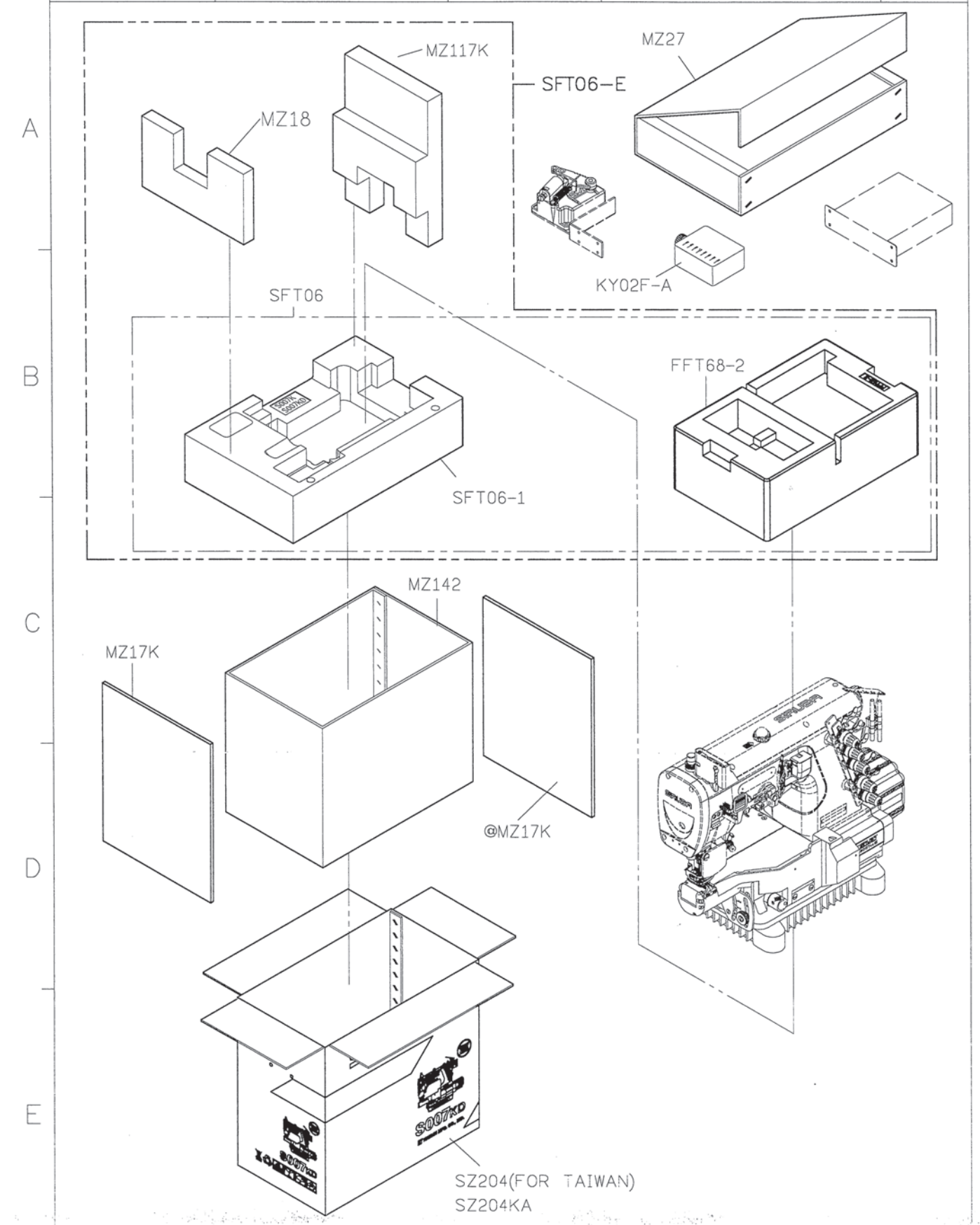

1 2 3 4 5

## 報廢流程

## DEMOLITION PROCEDURE

1. 當機器需要被淘汰與報廢時，有一些基本規則必須採納、遵守以保護環境及公眾健康。
  2. 所有的機器零組件必須依照下列分類來區分開：
    - (1) 所有護套、可伸縮軟管及塑膠或非金屬零件。
    - (2) 電器零件：開關、照明器具等。
    - (3) 絕緣材料：石棉、彈性/可伸縮橡膠片。
    - (4) 金屬：含鐵金屬、銅、青銅與黃銅、其他各種金屬。
  3. 以此方法，所有材質可以正確的淘汰，回收再利用或鎔解為可再使用或再處理而不至於危害環境。
1. When the machine needs to be eliminated and demolished, certain basic rules must be observed to protect the environment and public health.
  2. ALL machine componenets must be divided according to categories as the followings:
    - (1) All sheathes, flexible hosing and plastic or non-metal components.
    - (2) Electricity components: switches, or lighting components.
    - (3) Insulation materials: rock wool, and flexible rubber strips.
    - (4) Metals: ferrous metals, copper, bronze and brass, various.
  3. In this way, all materials can be eliminated correctly, recycled, or melted down for re-use or disposed of so that they do not harm the environment.