

# SIRUBA

使用說明書與零件圖

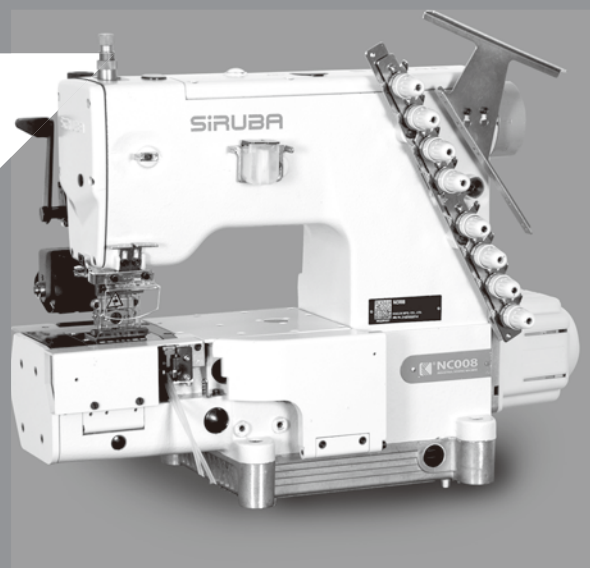

INSTRUCTIONS BOOK & PARTS LIST

■ NC008







CE

## 危險水準的說明 Explanation of Dangerous Level

 危險 Dangerous	<p>如果忽視此標記而運行了錯誤的機械操作，保養時肯定會引起當事者或第三者人員重傷或死亡。</p> <p>Don't ignore the warning sign and don't proceed incorrect operation. Or it will cause the person or the third party seriously injured or dead during maintenance.</p>
 注意 Caution	<p>如果忽視此標記而運行了錯誤的機械操作，保養時有可能會引起當事者或第三者人員受傷及造成設備損壞。</p> <p>Ignoring this warning sign and proceed incorrect operation will cause the person involved or the third party wounded and equipment damaged during maintenance.</p>

## 警告圖案表示及表示標誌的說明 Explanation of Warning Signs and Labels

警告圖案表示 Warning Sign		運動部位，謹防工傷事故 Moving part, beware of industrial accident
		高壓部位，謹防觸電事故 High voltage, beware of electric shock
		高溫部位，謹防燙傷事故 High temperature, beware of burns
指示標幟 Instruction Label		禁止 Prohibited
		地線的接線表示 Indication of ground wiring

索引	INDEX	頁 /PAGE
一般安全事項說明	GENERAL SAFETY INSTRUCTIONS	1
重要安全事項說明	IMPORTANT SAFETY INSTRUCTION	3
特別事項	WARNING	7
機器如何安裝	INSTALLATION OF MACHINE	8
潤滑油之注入與更換	LUBRICANT OIL FILLING AND REPLACEMENT	9
針之更換	REPLACE NEEDLES	10
針與穿線方式	NEEDLES & THREADING THE MACHINE	11
調整上軸與下軸的同步	TO ADJUST THE TIMING BETWEEN THE UPPER AND THE LOWER SHAFT	12
調整勾針與針的同步	TIMING OF THE LOOPER TO THE NEEDLES	12
調整撥線桿與勾針、 針的時位關係	TIMING OF THE RETAINER LOOPER	15
調整針與勾針護針器 的間隙	ADJUSTING CLEARANCE BETWEEN NEEDLE AND NEEDLE GUARD	17
送具護針片的調整	ADJUSTING OF THREAD RECEIVER	17
送具與縫距的長度調整	ADJUSTING THE FEED DOG& STITCH LENGTH	18
針棒針送的調整	ADJUSTING OF THE NEEDLE FEED	19
壓腳的調整	ADJUSTING THE PRESSER FOOT	20
後滾輪裝置的調整	ADJUSTING THE REAR PULLER DEVICE	21
線跡狀態調整	ADJUSTING THE STITCH FORMATION	22
桌板圖	TABLE CUT-OUT DIAGRAM	23
規格件表	GAGE PARTS LIST	24
零件圖	PARTS LIST	25

## 一般安全事項說明

## GENERAL SAFETY INSTRUCTIONS

### 警告！

當使用這台機器，基本安全預防應恆被遵守，以減輕火災、電擊、或是個人傷害的風險。包含以下注意事項。  
在操作這台機器之前，請閱讀所有說明並且緊記於心。

- 1. 保持工作場所清潔**  
雜亂的環境與椅子會招引危害。
- 2. 考量工作場所環境**  
勿暴露電源於雨水之中、勿在溼氣重的地方或潮濕的場所使用機械器具。保持工作場所良好整齊。當有引發火災或爆炸危險時，勿使用電源工具。
- 3. 免於電擊危害**  
避免身體接觸地線或是接地表面。(即：管線，發熱物體，以及冷凍庫)
- 4. 勿使孩童接近**  
不要讓訪客接觸工具或是延伸管線。
- 5. 適當的穿著**  
不要穿著寬鬆衣物或是穿戴珠寶，這可能被活動零件拉扯而導致危險。穿戴護髮套可包住長髮。
- 6. 不要任意拉扯電線**  
絕不要用電源端拉扯機器，或是從插座猛拉電線來拔掉電線。使電線遠離熱源、油類或是尖銳邊緣。
- 7. 謹慎保養機器**  
遵從指示來添加潤滑油或是更換附件。定期檢測工具用線，如果有所損害，請使用合格的維修器具來修復。

### Warning!

When using this machine, basic safety Precautions should always be followed to reduce the risk of fire, electric shock and personal injury, including the followings. Read all these instructions before operating this product and save these instructions.

- 1. Keep work area clean**  
Cluttered areas and benches invite injuries.
- 2. Consider work area environment**  
Do not expose power to rain. Do not use machine tools in damp or wet locations. Keep work area well lit.  
Do not use power tools where there is risk to cause any fire or explosion.
- 3. Guard against electric shock**  
Avoid body contact with earthed or grounded surfaces (e.g. Pipes, radiators, ranges refrigerators.)
- 4. Keep children away**  
Do not let visitors touch the tool or extension code.
- 5. Dress properly**  
Do not wear loose clothing or jewelry, they can be caught in moving parts. Wear protecting hair covering to contain long hair.
- 6. Do not abuse the cord**  
Never carry the machine by cord or yank it to disconnect it from the socket. Keep the cord away from heat, oil, and sharp edges..
- 7. Maintain machine with care**  
Follow instructions for lubrication and changing accessories. Inspect tool cord periodically. If damaged, have it repaired by an authorized service facility.

## 8. 中斷機器電源

當不使用機器時、維修前、以及更換配件時。

## 9. 避免誤啟動

不要以手指置於啟動開關上之後，搬運一個已插入電源的工具。確定在插電之前，電源開關是關閉的。

## 10. 檢查損害零件

在進一步使用器具之前，應該小心檢查並確認損傷的零件或是穿戴保護器具來確認零件會正確運轉並且呈現應有功能。

## 11. 警告

除了在這本使用說明手冊中建議的功能之外，任何附件或是配件的使用，都可能會導致個人傷害的危險。

## 12. 由合格人員來修理器具

所以修理工作應由合格的人員使用原始個別零件來作修理。

### 連接電源的特別警示！

1. 只可與有 "CE" 認證的按壓啟動裝置連接這台機器。
2. 遵守此使用說明手冊來安裝控制裝置。
3. 在操作過程中，永遠保持機器適當的接地。
4. 在調整、更換零件、或是維修保養之前，必須確定將插頭由插座拔出，以預防任何機器意料之外的啟動而造成危害。

## 8. Disconnect machine

When not in use, before servicing and when changing accessories.

## 9. Avoid unintentional starting

Do not carry a plug-in tool with a finger on the switch. Ensure the power switch is off when plugging in.

## 10. Check damaged parts

Before further use of the tool, a guard or other part that is damaged should be carefully checked to determine that it will operate properly and perform its intended function.

## 11. Warning

The use of any accessory or attachment, other than those recommended in this instruction manual, may present a risk of personal injury.

## 12. Have your tool repaired by a qualified person







Repairs should only be carried out by qualified persons using original spare parts.

### SPECIAL WARNING FOR ELECTRIC CONNECTION!

1. Incorporate this machine only with "CE" certificate hold-to-run control device.
2. Follow the instruction manual device to install control device.
3. Always earth machine appropriately during operation.
4. Before adjustment, parts change or servicing must be sure to pull out the plug from socket to prevent the hazard of unintentionally start of machine.





## 重要安全事項說明



恭喜您購買本機器，為了使這台機器能獲得最佳功能以及安全的操作，務必請正確的使用這台機器，使用前請仔細閱讀使用說明書，希望您能長期使用它。請記得將此說明書放在容易取得的地方。

-  1. 當您使用機器時，除了以下事項外，請注意其他基本安全措施。
-  2. 使用機器前，除了本使用說明書外，請詳細閱讀其他相關說明書。此外，請妥善保存此說明書，以便需要時可以隨時取閱。
-  3. 先確認機器是符合貴國安全規定及標準後，再使用機器。
-  4. 當機器完成操作時，所有安全配備必須安裝就緒，在缺少所述安全配備下操作是不被允許的，以免導致人員受傷。
-  5. 此機器應由受過適當訓練之操作員操作。
-  6. 為了安全，我們建議您配戴安全眼鏡。
-  7. 以下情形，請先關閉電源或拔掉插頭：
  - (1) 穿針線、導線片、天平等以及更換梭子時。
  - (2) 更換針、壓具、針板、送具、頂針片、車布導板，以及其他附屬配件時。
  - (3) 維修工作時。
  - (4) 離開工作場所或工作場所無人看顧時。

## IMPORTANT SAFETY INSTRUCTION

For operating safely and getting the best functions of this machine, you must operate it correctly. Please read and follow the instructions of this manual, and keep it at hand for future references. We are confident that you will enjoy this machine as much as we enjoy manufacturing it.

-  1. Instead of the following instructions, when you use this machine, please pay attention to the basic safety measures.
-  2. Before using this machine, please read this manual and all related instructions. In addition, please keep this manual for future needs.
-  3. Before using this machine, please ascertain that it conforms with safety standards and regulations of your country.
-  4. When the machine is ready for operation, all the safety equipments must be ready. Operate this machine without the specified safety devices is not allowed.
-  5. This machine must be operated by a properly trained operator.
-  6. For your own safety, we suggest you wearing goggles.
-  7. Please turn off the power switch or disconnect it for any one of the circumstances of the followings:
  - (1) When threading needle(s), adjusting thread Take-up(s), thread guide(s), and/or replacing bobbin(s).
  - (2) When replacing needles, presser feet, needle plates, feed dogs, needle guards, cloth guides and other parts or accessories.
  - (3) When repairing.
  - (4) When the operator leaves the working place or leaves the machine unattended.

 8. 假如不慎讓機器及配件使用之油或油脂，接觸到眼睛、皮膚或誤食時，請立刻以水清洗接觸部位及就診。  



 9. 請勿擅自碰觸運轉中之零件及配件及注意機器電源是否已開啟，以免導致人員受傷。

 10. 維修、修改及調整等工作，須由受過適當訓練的技師或熟手為之。維修時只許使用指定之零件。

 11. 一般維修及檢查工作必須由受過適當訓練的人員為之。

 12. 電子零件維修及保養工作必須由資深的電子技師為之，或由非常熟練的人員檢查及指導，當發現零件損壞時，請立刻停止機器運轉。

 13. 在做裝有氣動式零件（例如氣缸）機器的維修及保養工作前，機器連接空壓機及高壓空氣必須予以關閉及卸除，機器中殘存高壓氣體必須予以消除，此外調整及性能檢查只能由受過適當訓練的技師或熟手為之。

 14. 機器使用一段時間，必須定期清理。

 8. If grease, oil, or any fluid contacts your skin or eyes by any chance, please wash the contacted area completely with clean water and consult a doctor. Or, swallow any fluid mistakenly, consult a doctor immediately.

 9. Do not touch any functioning parts and devices. Always attend to whether power switch is on or off before operating in order to prevent anyone from getting hurts.

 10. Qualified technicians are required for adjustment, modification, and repair. Only use assigned parts for replacement.

 11. Routine maintenance and service must be performed by well trained persons, or qualified technicians.

 12. Maintain and check the electronic parts must be done by qualified electrician or well-trained persons. If any electronic part damaged or malfunctioned, stop the machine immediately.

 13. The air house has to be detached from the machine and the compressor or air supply has to be cut off before repairing and servicing the machine equipped with pneumatic parts such as an air cylinder. Qualified technicians or well-trained persons are required for adjustment and repairs.

 14. To ensure the best performance, periodically clean the machine is necessary.

 15. 為使機器能正常操作以及減少噪音，機台務必平放地上，機器避免在強烈噪音的環境下操作。

 16. 選用適當的電源插頭，並由電子技師將其安裝在機器上，且插頭必須插在接地線之插座上。

 17. 機器只允許被使用於指定用途上，其他用途是不允許的。

 18. 修改或變更機器必須依照安全規定及標準，同時採取有效的安全措施或變更機器所引起損壞之責。

 19. 警告提示以兩種符號標示：

(1) 對操作員或服務人員之傷害危險，也為了避免觸電之危險，請勿打開馬達電器箱之外蓋，也不要觸摸電器箱裡面之零件。

 (2) 必須特別注意事項  
a. 絕對不可在移動外蓋，手指保護蓋或安全配件後，進行機器操作，以免導致人員受傷。

b. 為了避免被機器纏住，當機器運轉中，您的手、頭髮及衣服，需遠離手輪；此外這些部位周圍不可放置任何物品，以免導致人員受傷。

 15. In order to operate properly and to reduce the noise, please place the machine flat and level on the ground. Avoid operating the sewing machine at a noisy surrounding.

 16. Select a proper power plug and install it by an electrician. Please connect the power plug to a grounded receptacle.

 17. This machine can only be used for the designed purpose. Other uses of this machine are not allowed.

 18. Any modification or conversion made on this machine must be conformed with the safety standards and regulations. Precaution is necessary. No responsibility will our company take for damages caused by any modification or conversion of this machine without permission.

 19. Two safety warning signs are applied as warning signs:

(1) For the safety of operators and service persons, please don't open the cover of any electronic control boxes of motor or other devices and don't touch any components inside to avoid electrical shock hazards.

 (2) Always keep in mind:  
a. Please never operate this machine without outer cover, finger guard or any safety device to avoid physical injury.

b. Please keep your hair, fingers and clothes away from the hand wheel while the machine is in operation, as well as never put anything near these parts, to prevent the risk of injuries by tangled into them.





 c. 當您打開電源開關後或機器已在運轉中，絕不可將您的手放在針的下方或針線控線桿外蓋中，以免導致人員受傷。

 d. 當機器運轉中，梭頭高速轉動，為了避免對手可能引起之傷害，必須確定您的手保持遠離梭頭附近。此外，當更換梭子時，確定電源開關已關閉，以免導致人員受傷。

 e. 當放置或抬起機器時，小心勿將手置於機器中，以免導致人員受傷。

 f. 為了避免機器突然啟動而引起可能意外，當機頭傾斜時，請關掉機器電源，以免導致人員受傷。

 g. 如果您的機器是配置伺服馬達，機器於靜止狀態時，馬達是不會產生噪音的，為了避免機器突然啟動而引起可能意外，故請關掉機器電源。

 h. 為了避免觸電之危險，請絕不要在移開電源接地線後操作機器。

 i. 為了避免觸電或電子零件損壞而引起之可能意外，請先切斷電源，再插上或拔掉插頭。

 c. Please never put your fingers under the needle(s) or in the thread take-up cover to prevent physical injuries when you turn on the power switch or operate the machine.

 d. While the machine is in operation, the hook rotates at a high speed. Please keep your hands away from the area of hook to prevent any potential injury to your hands. In addition, please make sure to turn off the power of the machine while changing bobbins.

 e. Be careful and do not place your fingers inside the machine when placing or lifting the machine head to avoid possible physical injuries.

 f. Please turn off the power before tilting the machine head to avoid possible accidents due to abrupt start of this machine.

 g. For machine equipped servo motors, the motors do not produce noise while the machines are at rest. Therefore, please turn off the power of this accidents due to abrupt start of the machine.

 h. Never operate the sewing machine after the ground wire is removed to avoid electrical shock hazards.

 i. Please turn the power switch off before connecting or disconnecting the power plug to prevent possible accidents due to electric shock or damaged electronic components.

## 特別事項

## WARNING

為了避免機器故障及損壞，請先確定以下事項：







-  1. 當您安裝好機器後，做第一次機器操作前，請徹底清潔機器。
-  2. 清除運送途中累積之灰塵及溢出之油脂。
-  3. 確定電壓及馬達相數（單相或三相）安裝正確。
-  4. 確定電源插頭正確地接上電源。
-  5. 當使用電壓與標示電壓不同時，請勿使用機器。
-  6. 確定機器轉動方向是否正確。



警告：

在操作或調整本書中所提到之各步驟前，請先將電源關掉，以免因為機器突然啟動造成之意外。

Please confirm the followings to avoid malfunction or damage to this machine.

-  1. After installing the machine, and before the first operation, please clean it completely.
-  2. Clean all dust and overflowed oil during transportation.
-  3. Confirm that the voltage and the phase (single or 3 phase) of motor are set correctly.
-  4. Confirm that the power plug is correctly connected to the power supply.
-  5. Never use the machine when the local voltage type is different from the marked voltage on the nametag attached on the machine.
-  6. Confirm that the rotating direction of the machine pulley is correct.



Warning:

Before doing any operation or any adjustment described later in this manual, please turn the power off to prevent accidents caused by abrupt start of the sewing machine.

## 機器如何安裝

## INSTALLATION OF MACHINE

1. 依本機器所附桌板裁製圖及零件組合圖所列之配件，依序安裝防震機座及線架。(圖 1.2)

1. With reference to diagrams for table cutting and mounting parts list, install rubber cushion and thread stand in sequence. (Fig. 1.2)



圖 1/Fig 1

2. 馬達之轉向為逆時針方向，皮帶之鬆緊度以用手指能向內壓 20mm 為宜，同時為安全起見請皮帶蓋必須鎖上。(圖 2)

3. 縫合轉速表及皮帶輪選擇對照表，請參照 (表 1.2)。

2. Motor should turn clockwise with proper tension for driving belt. It can be checked by pushing belt inward for 20mm. Please install belt cover properly for safety purpose (Fig. 2)

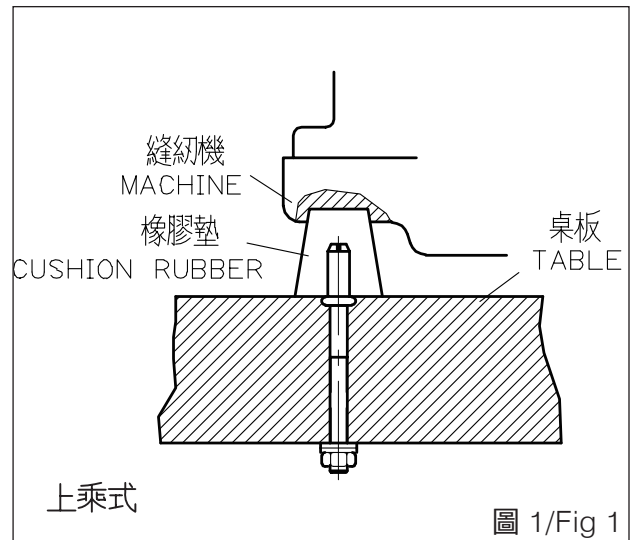
3. Motor pulley size and sewing speed, please refer to Table 1.2



圖 2/Fig 2

機種 Model	最高轉速 Maximum speed	出廠轉速 Standard speed
NC008-02	4000rpm	3500rpm
NC008-04	4000rpm	3500rpm
NC008-04PR	4000rpm	3500rpm
NC008-06	3000rpm	2500rpm

表 1/Table 1

馬達皮帶輪外徑 Motor pulley outer diameter(mm)	縫紉機轉 Machine speed(SPM)	
	50Hz	60Hz
60	3150	2950
70	2300	3450
80	3300	3900
90	3700	4400
100	4100	4900
110	4500	5400

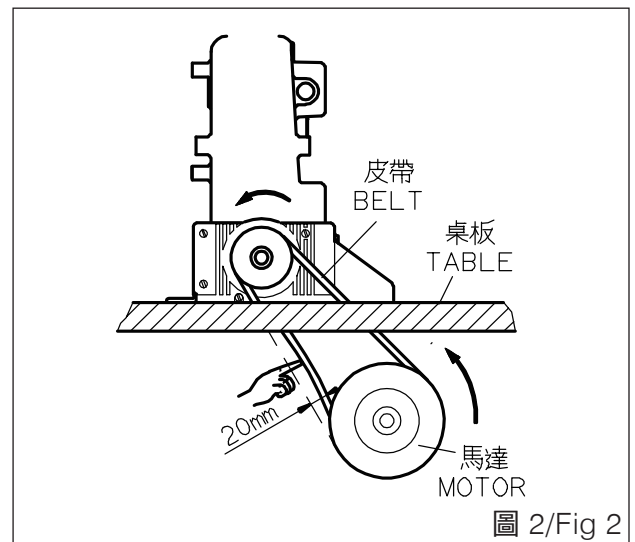
表 2/Table 2

**注意：**

1. 使用新機器最初一個月 (約 200 小時) 應以最高縫紉速度之 80% 運轉後，再用出廠速度運轉，能增加縫紉機壽命 (表 1)，並請選擇正確的馬達皮帶輪尺寸。(表 2)
2. 皮帶輪轉動方向為逆時針。(圖 2)
3. 桌板厚度約 45mm。
4. 馬達規格：離合器馬達，3 相 2 極 400 瓦 (1/2HP)。
5. 電壓：110V，220V，380V。
6. 皮帶規格：M 型 V 字皮帶。

**Remarks：**

1. New machines run a speed at approximately 80% of the Maximum speed in the first month (Table 1). Be sure to choose proper motor pulley for your machine (Table 2).
2. The motor pulley turns counterclockwise (Fig. 2)
3. Thickness of Table Top is about 45mm.
4. Specification of motor: Clutch motor 3 Phase, 2 poles, 400w (1/2 HP).
5. Voltage: 110V, 220V, 380V.
6. Driving Belt: M type, V belt.

## 潤滑油之注入與更換

新機器運裝前均已將油倒盡，因此機器使用前必須加入潤滑油。

請使用超高速潤滑油或 MOBIL#10 或 SSO#32 等級之潤滑油。

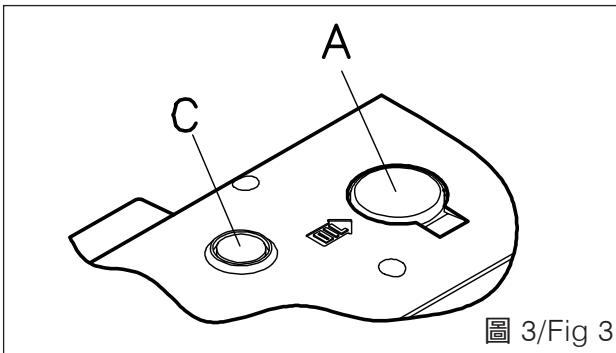

1. 潤滑油之注入：(圖 3.4)

- \* 打開注油口的油帽 (A)，加入潤滑油直至由窗 (B) 內之油標線中間即可，然後再蓋上 (A)，加完油後轉動一下縫紉機，確認一下油是否能打到油鏡 (C) 處。

## LUBRICANT OIL FILLING AND REPLACEMENT

Machine chamber is empty with no oil. Please fill lubricant oil into new machines before running.

Please choose with lubricant oil or its equivalent such as Mobil #10 or Esso #32

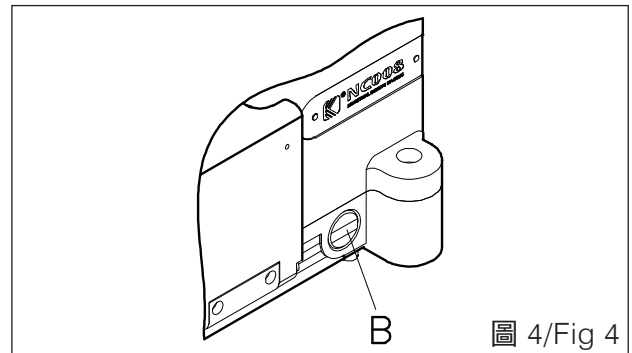

1. To fill lubricant oil: (Fig. 3.4)

- \* Loosen Knob (A), fill in with lubricant oil or its equivalent such as Mobil #10 or Esso #32. Please fill the oil up between two level lines on oil Indicator (C) and tighten Knob up.

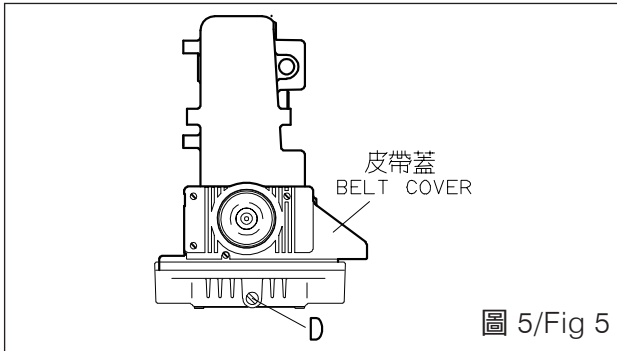

2. 潤滑油之更換：(圖 5)  
將螺絲 (D) 鬆開，使油槽之油完全排出後再鎖緊。  
\* 為延長本機器之壽命，請於開始使用四星期後更換新油，爾後約四個月更換一次。

3. 濾油器之更換：(圖 6)  
\* 機器約每使用一個月後應卸下清洗，必要時得更換新品。

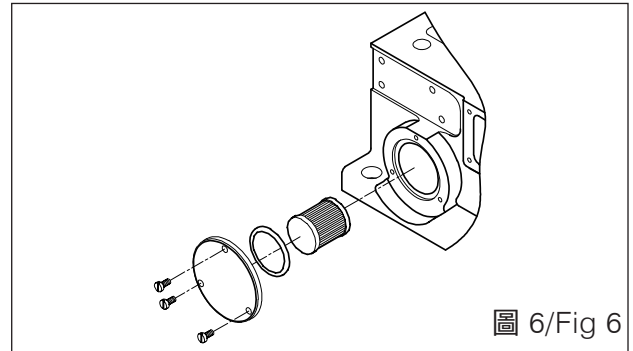

- 2.To replace lubricant oil : (Fig. 5)  
\*Loosen screw (D), drain oil from the oil tank & tighten it up.  
\*To extend the life of machine, please replace lubricant oil after the first 4 weeks operation. Thereafter, replace oil every 4 months.
- 3.To replace oil filter : (Fig. 6)  
\*Take filter out and clean up very month. Replace with new filters if necessary.

## 針之更換

## REPLACE NEEDLES

廠牌	針規格	針號
Schmetz	DVX57	Nm~Nm200
Organ	DVX57	#14~#25

表 3/Table 3

- \* 選用針之規格請參照 (表 3)

### 針安裝方法 (圖 7.8)

1. 旋鬆螺絲 (A) 並取下針。
2. 將新針插至針孔至最底端，並使針之長溝面向操作者左邊。
3. 重新鎖緊螺絲 (A)。
4. 如果車針安裝不正確，不但會引起跳針，斷線，還會損壞勾針，務必注意。

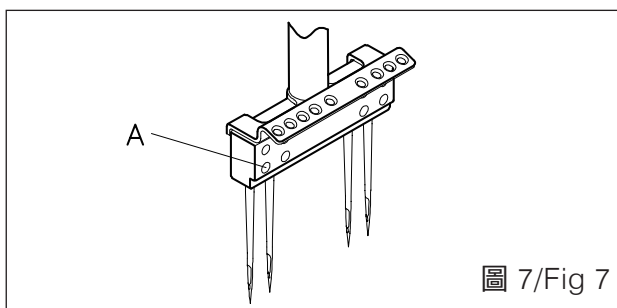

- \*Please refer to Table 3 for proper needle sizes.

### Installation (Fig 7.8)

- 1.Loosen Screw (A) and take out the used needle.
- 2.Put new needle into the needle clamp holes as far as they can go. The groove of needle should face user's left side.
- 3.Tighten Screw (A).
- 4.Improper needle setting will cause skipping stitches, breaking threads, and damaging loopers. Please pay attention to needle installation.

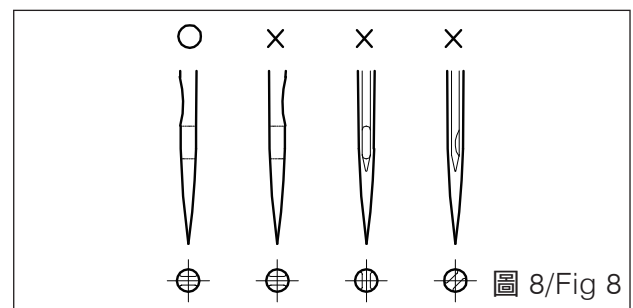

## 針與穿線方式

## NEEDLES & THREADING THE MACHINE



圖 9/ Fig 9

1. 請確實按照圖示之穿線，錯誤之穿線將引起斷線，跳針或車縫不平坦等現象，請參照穿線圖。(圖 9)

1. For needle threading, please thread arefully as. (Fig. 9) Please note: improper threading will cause breaking threads, skipping stitches, and / or undesired sewings.

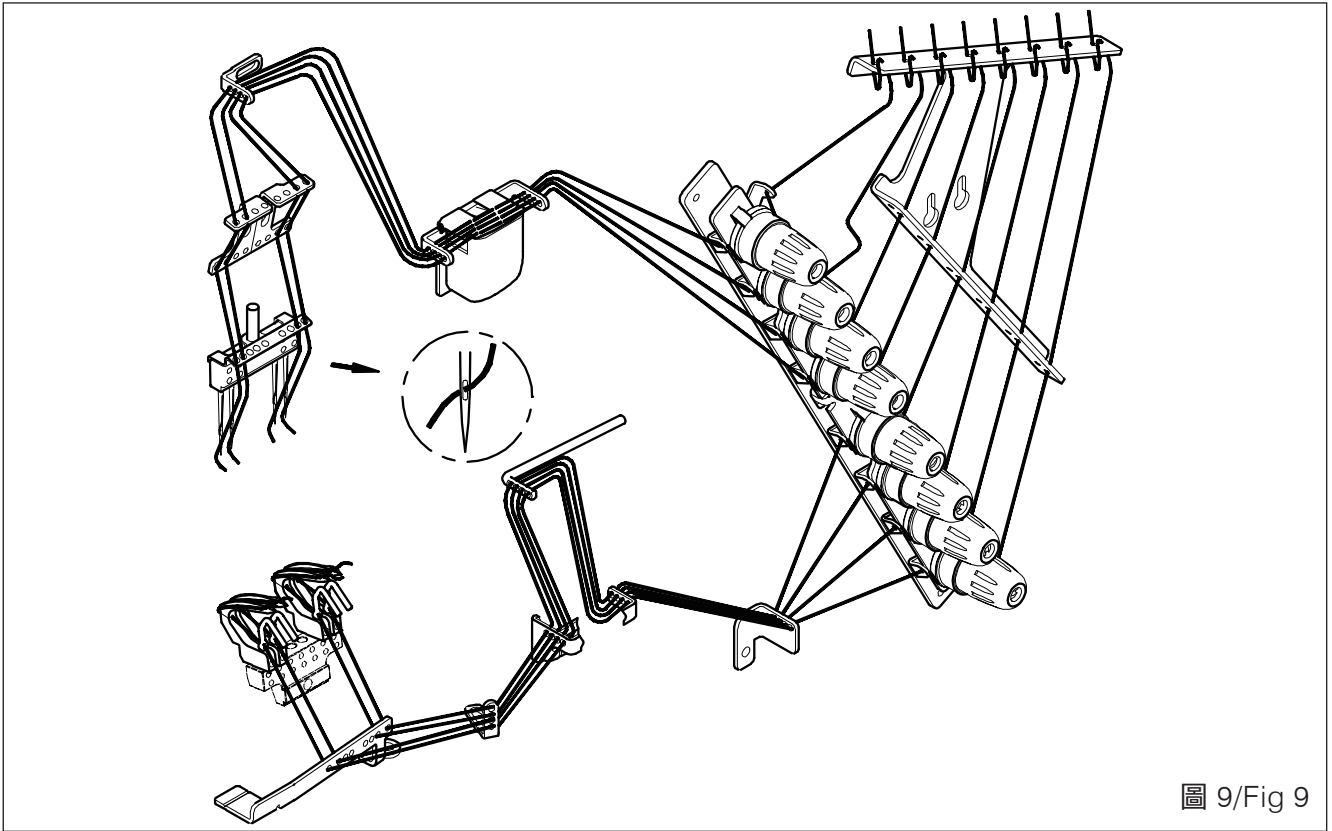

圖 10/ Fig 10

2. 將針棒轉至上死點後，將 (A) 翻開，用手指把拉桿 (B) 拉向箭頭方向，勾針座 (C) 與軸心分離，即可穿線。請參照 (圖 10)

2. Bring needle bar to the top of its stroke. open looper eyelet (A) , pull drawing lever (B) out to the arrow mark as shown in the illustration , so that the looper holder (C) is tilted toward the front of machine.(Fig.10)

## 調整上軸與下軸的同步

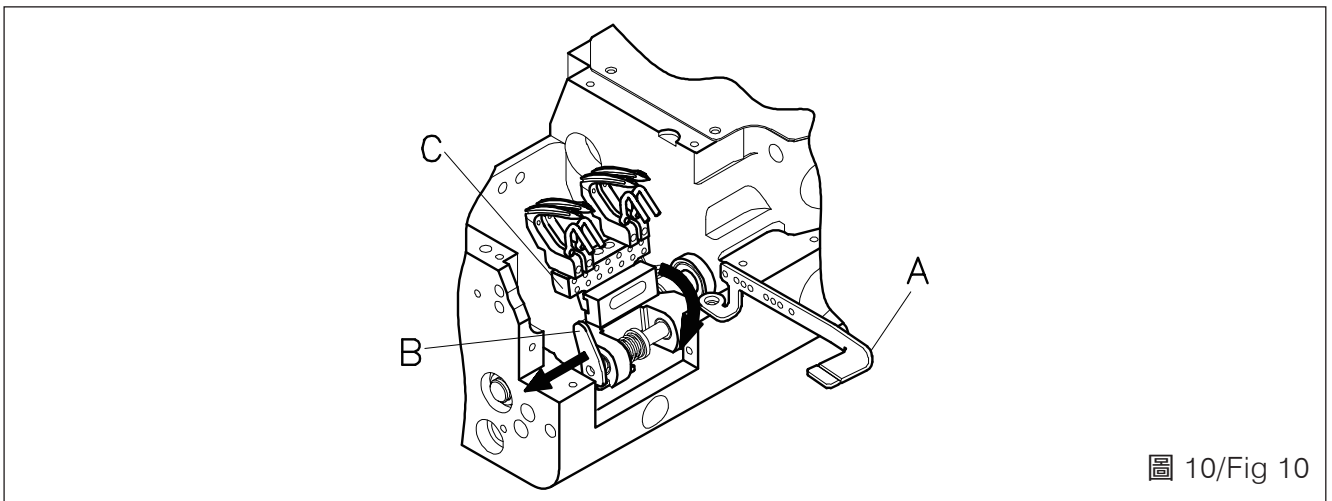
## TO ADJUST THE TIMING BETWEEN THE UPPER AND THE LOWER SHAFT



圖 11/11



圖 12/12

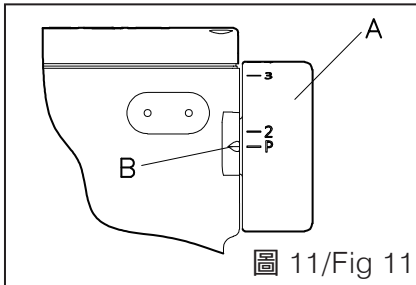

圖 13/13

1. 轉動手輪 (A)，把手刻度 P 對準記號 (B)，此時針棒位於上死點。(圖 11)
2. 此時，下軸 (C) 的端面線是垂直的，請確認皮帶輪 (D) 逆時針方向的第一顆螺絲向上。(圖 12)
3. 調整時，上軸皮帶輪 (E) 的 4 顆螺絲鬆開，轉動手輪 (F) 使手輪的刻度 LT 洞口與下軸 (C) 端面線垂直後，將上軸皮帶輪 (E) 的螺絲鎖緊。(圖 13)

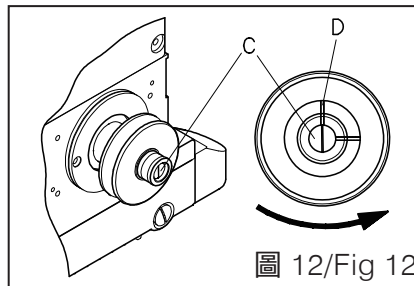
1. Turn the hand pulley (A) and align mark B on the hand wheel mark P. The needle bar position would be at the top of its stroke. (Fig 11)
2. In this case, the lower shaft (C) should be vertical. And make sure if the first screw of the turning direction is above the V-belt pulley (D) or not. (Fig 12)
3. If not, loosen screw (4pcs) on the timing pulley (E) of the upper shaft to be adjusted to the above-mentioned position. Make sure of tightening screw (G) (4pcs) again after adjustment. (Fig 13)

## 調整勾針與針的同步

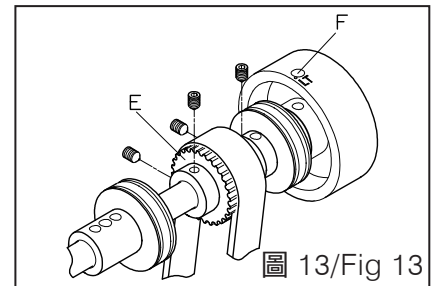
## TIMING OF THE LOOPER TO THE NEEDLES



圖 14/14



圖 15/15

1. 勾針和勾針座的角為 90 度 ~ 92 度。(圖 14)
2. 左右移動勾針座，使勾針 (A) 的尖點與針的凹槽處間隙為 0 ~ 0.1mm。(圖 15)

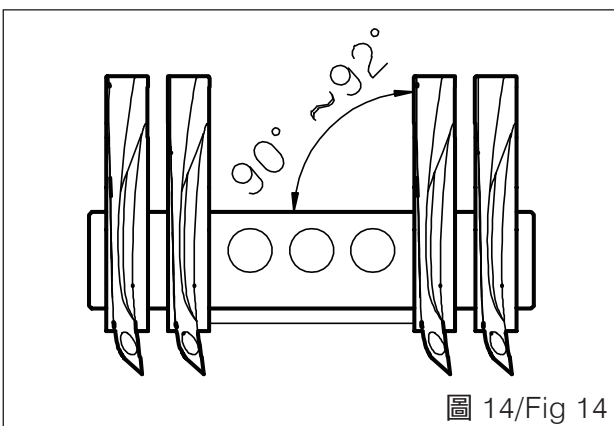
1. The angle between the needle and the looper is 90~92 degrees. (Fig 14)
2. The clearance between the looper and the needle when the point of looper passes the scarf of the needle should be 0~0.1mm. (Fig 15)

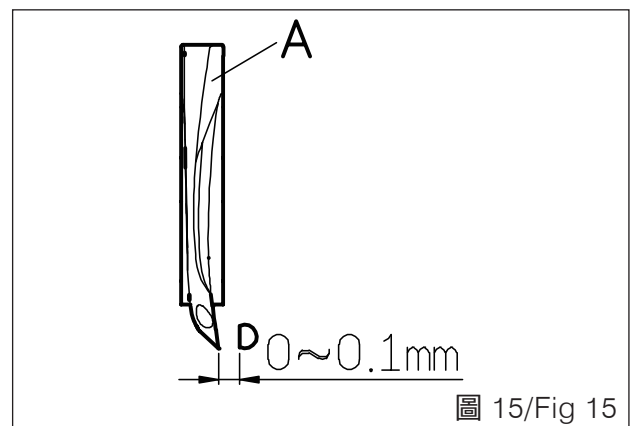

圖 16/16



圖 17/17

3. 調整勾針和針的同步：

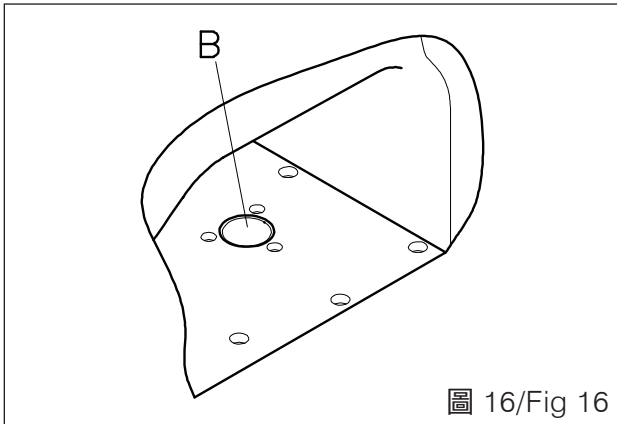
按下按鈕 (B)，轉動手輪 (C)，按鈕在某處陷入，請在陷入的狀態下轉動手輪 (C)，使手輪 (C) 的刻度 3 對準標記 (D)。(圖 16.17)

3. Timing of the looper to the needle :

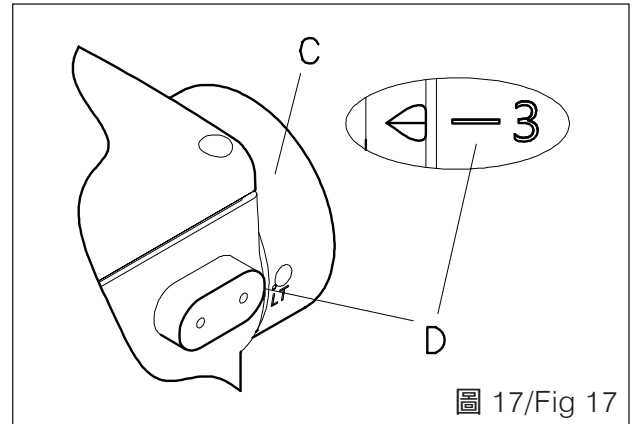
push button (B) and turn the hand pulley (C) pressing lightly until the push button touches an inside parts and clicks. And align mark C with the scale no.3 on the hand pulley B. (Fig 16.17)



圖 18/18

4. 把手離開按鈕，轉動手輪 (C)，使手輪 (C) 的刻度 LT 對準標記 (E)。(圖 18)

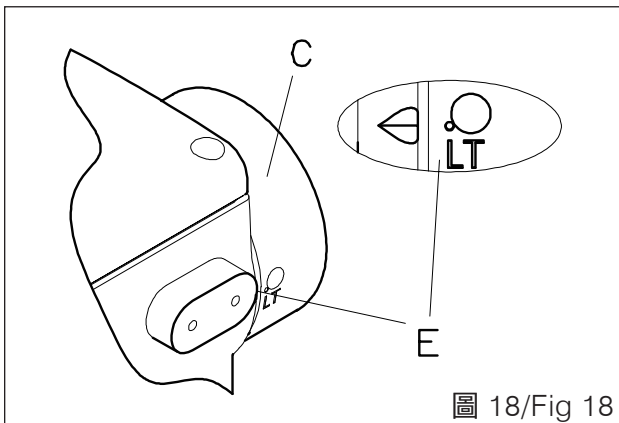

圖 19/19

4. Detach your hand from the push button (A). Then turn the hand pulley (C) and align mark (E) with the scale LT on the hand pulley (C). (Fig 18)

5. 轉動手輪 (圖 19)，當勾針由右死點往左移至針的中心處，勾針尖與針孔上緣處距離 1.6~1.8mm，反之，由左死點移至針的中心處，勾針尖與針孔上緣處距離 1.6~1.8mm。

5. In this case, turn the hand pulley (Fig 19) and check that the point of looper is 1.6~1.8mm above the needle eye when the point of looper, moving both to the right and to the left, reach to the center of the needle.

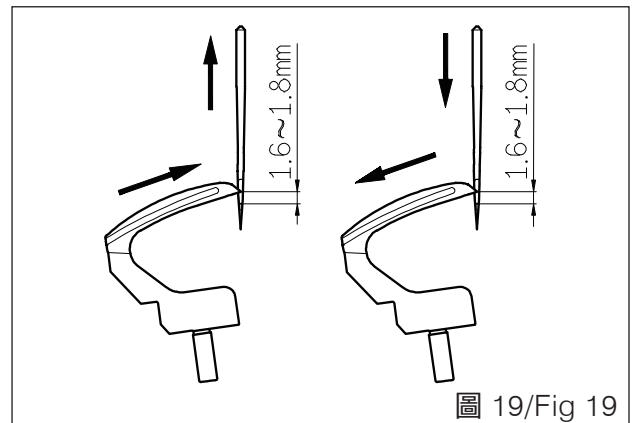
\* 出廠時手輪的標準調整為 3。

\* In the beginning, the hand pulley would be adjusted to scale no.3



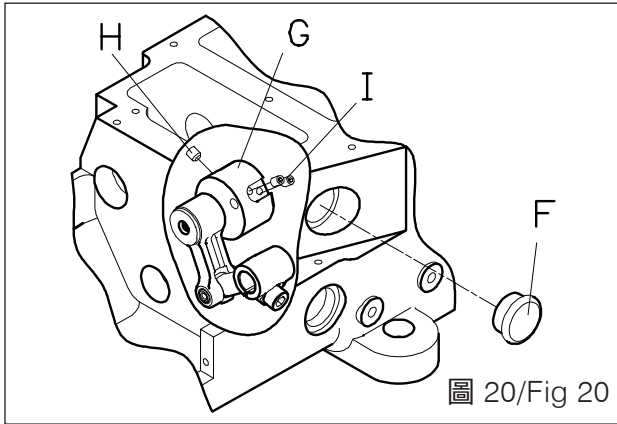

7. 調整時位時，請拆下橡膠塞 (F)，鬆開勾針偏心輪 (G) 的兩個固定螺絲 (H)，再鬆開勾針偏心輪 (G) 的兩個螺絲後 (I)，一面確認時位同步，一面鎖緊螺絲，調整勾針與針的時位同步後，請確認螺絲必須鎖緊。(圖 20)

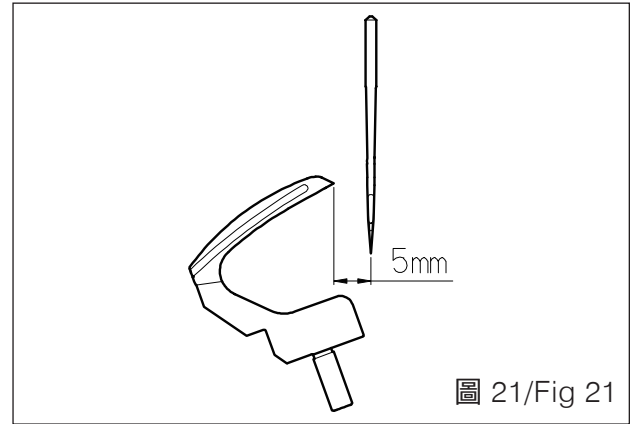

7. Remove the rubber plug (F) and loosen screw (H) (2pcs) and screw (I) (2pcs) in the looper eccentric (G) to adjust appropriate timing. Make sure tighten screws (H) again one by one. (Fig 20)

8. 勾針的退距，是在手輪刻度為 3 的狀態下，如 (圖 18) 所示，當勾針退到後死點，勾針尖點至針中心距離為 5mm。(圖 21)

8. When the needle bar is at the bottom of its stroke, there should be a distance of approximately 5mm from the point of the looper to the center of the needle. (Fig 21)

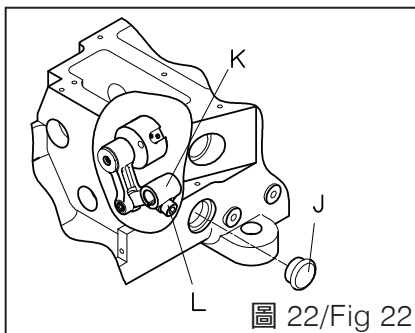

9. 調整勾針退距時，請鬆開橡膠 (J)，再鬆開勾針連桿 (K) 的固定螺絲 (L) 後進行調整，調整完後鎖緊螺絲 (L)。(圖 22)

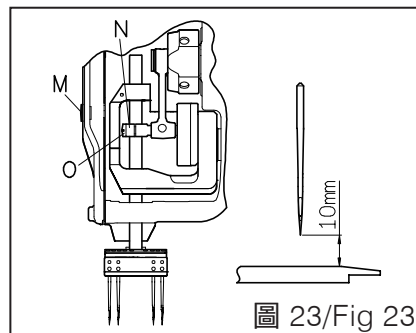

9. The adjustment for the looper setting distance is made by removing plug (J) and loosening screw (L) for the lever (K). After adjusting, tighten screw (L). (Fig 22)

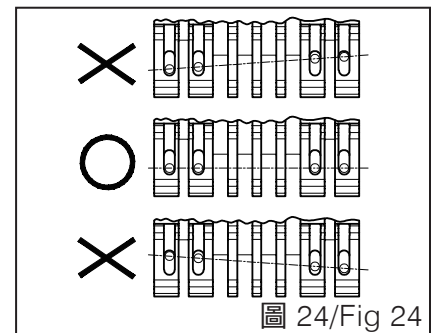

10. 針高度調整，針在上死點時，針板面與針尖距離為 10mm，調整時，請拆下橡膠塞 (M)，鬆開夾緊桿 (N) 的固定螺絲 (O)，上下移動針棒至定位後鎖緊。(圖 23) 請確認針落在針孔中心。(圖 24)

10. The adjustment needle height, when the needle bar is at the top of its stroke, there should be a distance of approximately 10mm from the top surface of the needle plate to point of the needle. Adjustment is made by loosening screw (O) of the needle bar bracket (N) after removing plug (M). After the adjustment is made (Fig 23), check to make sure each needle drops correctly into the center of each needle drop hole. (Fig 24)

## 調整撥線桿與勾針、針的時位關係

## TIMING OF THE LOOPER TO THE NEEDLES



圖 25/25

### 1. 撥線桿與針的前後位置：

當針向下時，針 (A) 的尖點和撥線桿 (B) 的尖點在同一個高度時，針與撥線桿的前後距離為 2~2.2mm。(圖 25)，調整方式是鬆開撥線桿 (B) 的固定螺絲 (C)，可進行前後調整。

\* 縫距改變較大時，間隙與時位也會發生改變，此時需要調整。

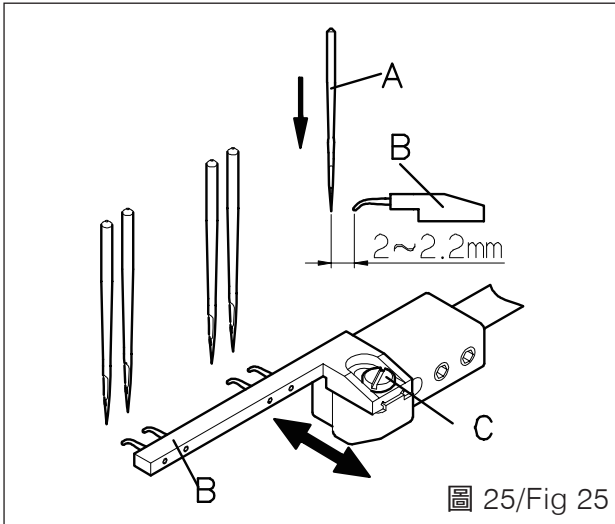
### 2. 調整撥線桿的左右位置：

當針 (A) 向下，針 (A) 尖與撥線桿 (B) 尖點在同一個高度時，針 (A) 尖點與撥線桿 (B) 左側邊緣處距離為 0.8~1.3mm。(圖 26)，調整方式是鬆開撥線桿 (B) 的固定螺絲 (D)，可進行左右調整。



圖 26/26

### 1. Front to back position of the retainer looper :

When the needle bar descend from the top to the bottom of its stroke and the point of the needle (A) is same height as the point of the looper retainer (B), there should be a clearance of 2.0~2.2mm between the point of needle and the point of looper retainer. (Fig 25) when adjusting, loosen the screw (C) of the looper retainer bar (B) and adjust the front to back position.

\* When the stitch length is changed much, necessary to the adjust again because the clearance would be changed.

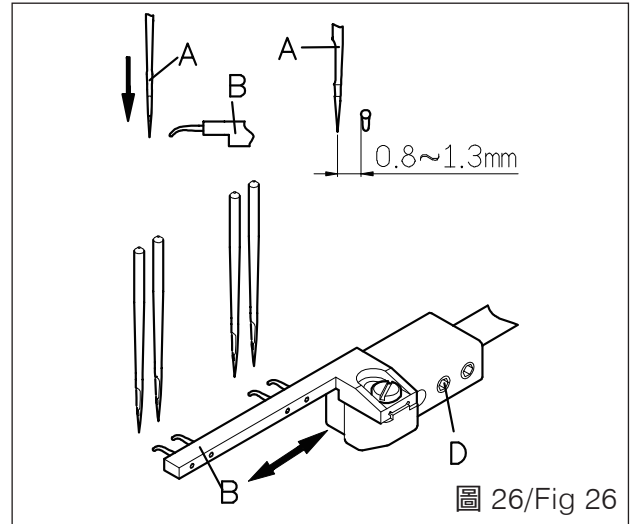
### 2. Left to right position of the retainer looper :

When the needle bar (A) descend from the top to the bottom, the needle (A) is same height as the point of the looper retainer (B), there should be a clearance of 0.8~1.3mm. (Fig 26), when adjusting, loosen the screw (D) of the looper retainer bar (B) and adjust the Left to right position.

### 3. 調整勾針與撥線桿的間隙 (圖 27) :

當撥線桿 (B) 最接近勾針 (E) 上緣時，撥線桿 (B) 尖點與勾針 (E) 上緣間隙為 0.1~0.4mm，調整方式是鬆開撥線桿 (B) 的固定螺絲 (D)，可進行間隙的調整。

### 3.Adjusting the height of the retainer looper (Fig 27) :

The retainer looper (B) is the nearest position to the top of the looper (E), there should be a clearance of 0.1~0.4mm between the point of the retainer looper (B) and the top of looper (E). When adjusting, loosen the screw (D) of the retainer looper holde (B)



圖 27/Fig 27



圖 28/Fig 28

### 4. 調整鬆線器的快慢 :

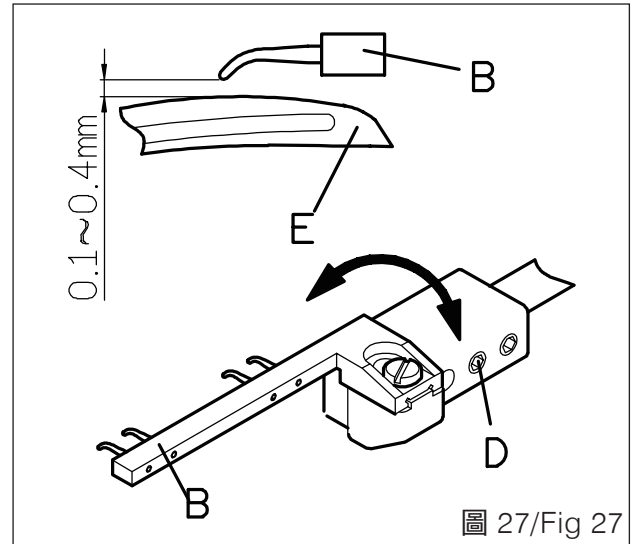
拆下上蓋 (F) 及墊片 (G)，拆下座的蓋型螺絲 (H) 及 O 型環 (I)，鬆開撥線桿偏心輪 (J) 的兩個螺絲 (K)，轉動撥線桿偏心輪 (J) 進行調整，標準狀態下撥線桿偏心輪的標記 (M) 應該對應下軸 (N) 的標記 (O)，如果旋轉方向往標記 (P) 方向轉，撥線桿 (B) 及鬆線器 (L) 的動作會比勾針快；如果旋轉方向往標記 (Q) 方向轉，撥線桿 (B) 及鬆線器 (L) 的動作會比勾針慢。(圖 28.29)

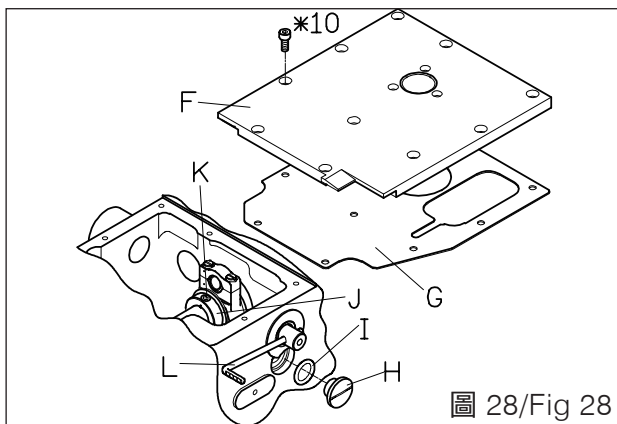

圖 29/Fig 29

### 4.Timing of the retainer looper to the needle :

Remove the upper cover (F) and gasket (G). Remove the screw (H) and o-ring (I) of the bed.

Loosen the screw (K)(2 pieces) of the retainer looper eccentric (J). Adjust by turning of the retainer looper eccentric. It is a standard setting to align the mark (M) on the retainer looper eccentric (J) to the mark (O) on the lower shaft (N).

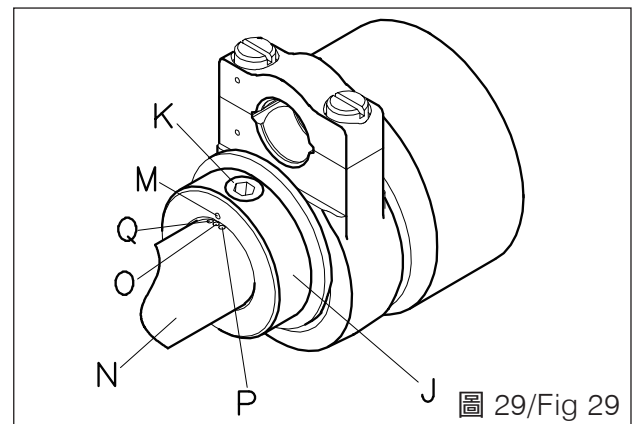
When aligning the mark (M) to the mark (P) which is a front of the rotating direction, the moving speed of the retainer looper and the looper thread take-up lever (L) against the needle and the looper should be faster. When aligning the mark (M) to the mark (Q) which is a back of the rotating direction, its moving speed should be slower.(Fig.28.29)

\* 調整完後，請再次確認撥線桿前後位置、左右位置、間隙。

\*After this adjusting, confirm to the position of front/back, the position of left/right and the height of the retainer looper.

## 調整針與勾針護針器的間隙

## ADJUSTING CLEARANCE BETWEEN NEEDLE AND NEEDLE GUARD

1. 勾針護針器 (A) 往右輕壓住針 (B)。(圖 30)

1. Adjustment should be made by pushing of the needle guard (A) to the needle (B) at 0~0.05mm. (Fig 30)



圖 30/Fig 30

## 送具護針片的調整

## ADJUSTING OF THREAD RECEIVER

1. 送具護針片 (C) 和針 (B) 的左右方向間隙為 0.8~1mm。送具護針片 (C) 最前緣與針 (B) 的最前緣齊平。(圖 31)

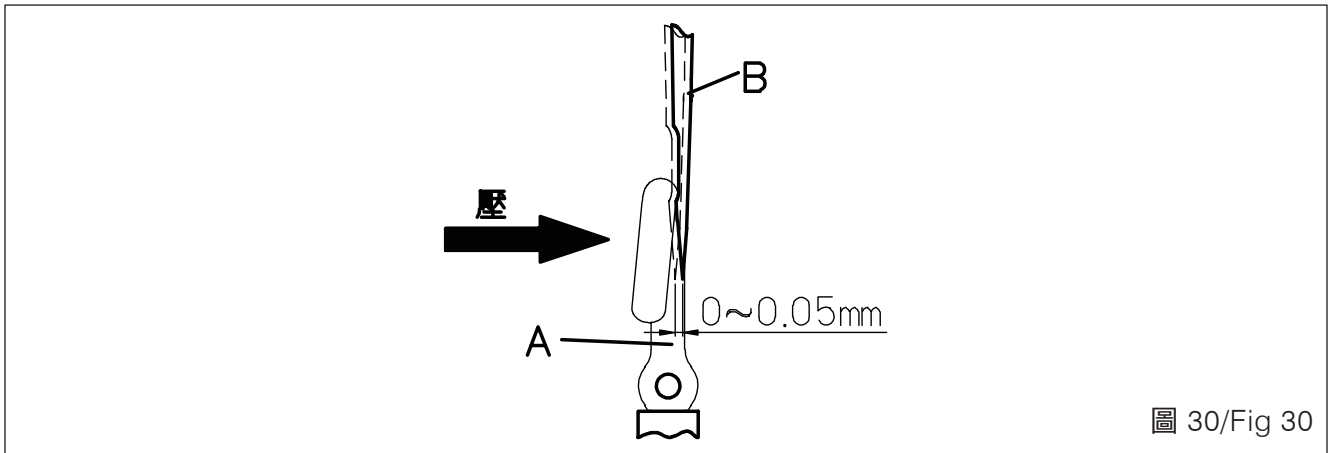
1. The clearance of left-right direction between the needle (B) and the thread receiver (C) of the feed dog (A) is 0.8~1.0mm. (Fig 31)



圖 31/Fig 31

## 送具與縫距的長度調整

## ADJUSTING THE FEED DOG &amp; STITCH LENGTH

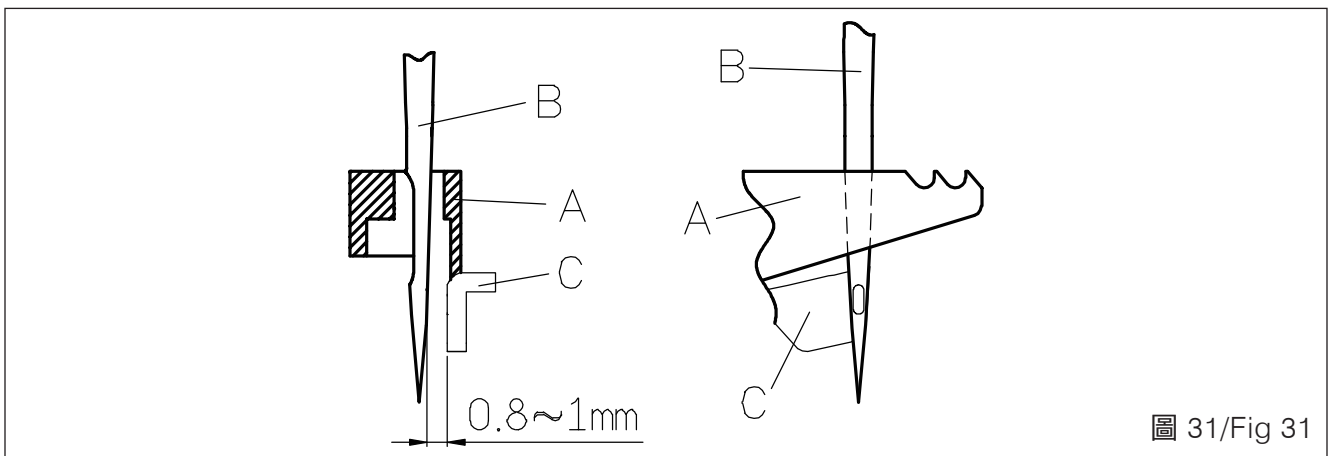

圖 32/ Fig 32

## 1. 送具的左右與前後位置調整：

請轉動手輪確認針 (A) 是否有對到送具的針孔 (B)，調整時，鬆開送具台 (C) 的兩個螺絲 (D) 後左右調整。此時，請鬆開針板 (E) 的三顆螺絲 (F)，使針板 (E) 與送具 (G) 平行，且送具進行前後運動時，前死點與後死點的送布槽間隙 (H) 需相等。(圖 32)

## 2. 調整送具的高度：

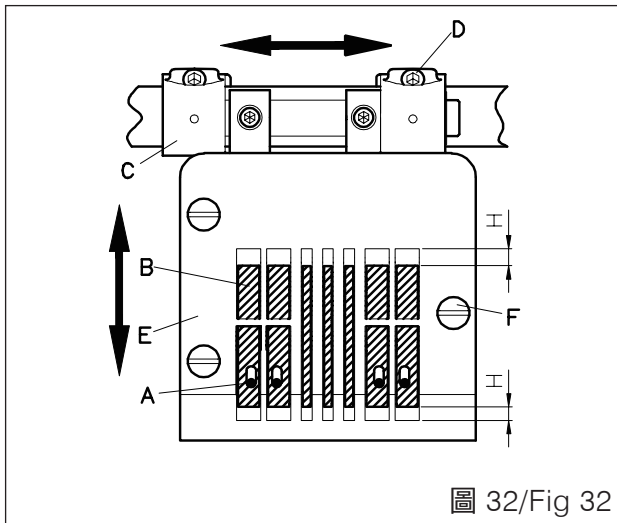
送具位於上死點時，送具 (G) 與針板 (E) 面平行，高度為 1~1.2mm，調整時請鬆開送具 (G) 的螺絲 (I) 和螺帽 (J) 與調整螺絲 (K)，上下調整送具 (G) 後鎖緊固定螺絲 (I)，然後使調整螺絲 (K) 觸碰到送具台，再固定螺帽 (J)。

\* 另外請拆下橡膠塞 (L)，鬆開連接桿 (M) 的螺絲 (N)，調整送具的傾斜度。(圖 33)



圖 33/ Fig 33

## 1. Adjusting of left-right position for the feed dog :

Make sure each needles (A) drops into the center of the needle drop hole (B).

Adjusting at left and right by loosening of the screw (D) (2 pieces) of the feed rocker (C).

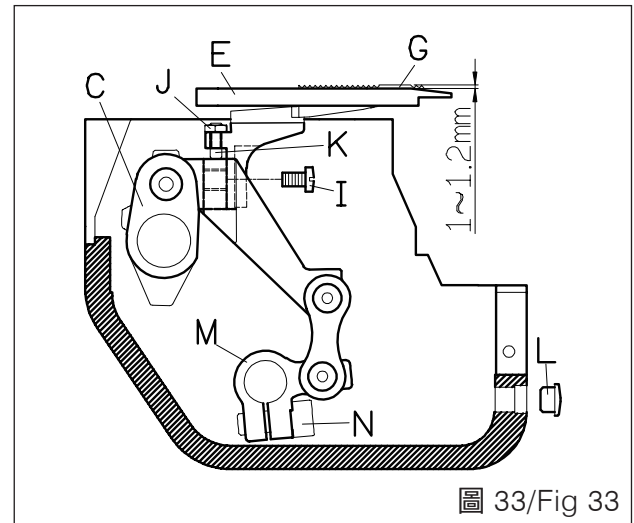
At the same time, adjusting by loosening of the screw (F) (3 pieces) of the needle plate (E), in order to be equal between each clearance (G) and also to be parallel between the feed dog and the feed grooves of the needle plate (E). (Fig 32)

## 2. Adjusting of height for the feed dog :

When the feed dog is at the upper dead point, the feed dog (G) is to be parallel with the top surface of the needle plate (E). Its height is 1.0~1.2mm.

Adjusting by loosening of screw (I) and nut (J) and adjusting screw (K) of the feed dog (G).

After adjusting by up and down of the feed dog (G), fasten the screw (I). Then, fix the adjusting screw (K) up by the nut (J) after slight-touching it to the feed rocker.

Tilt adjustment is to be done by loosening of the screw (N) of the feed up-down lever (M) after removing of the rubber plug (L). (Fig 33)

表 4/Table 4

皮帶輪位置	縫距 (mm)	線跡數	
		1 英吋	30 毫米
2	2.1	12	14
3	3.0	8.5	10
4	4.0	6.2	7.5
5	5.0	5.0	6.0
6	6.0	4.2	5.0
L	6.4	4.0	4.5

3. 縫距可在 2.1~6.4mm 之間調整。(表 4)

3.The stitch length can be adjusted from 2.1 up to 6.4mm without step.(Fig.4)

## 針棒針送的調整

## ADJUSTING OF THE NEEDLE FEED

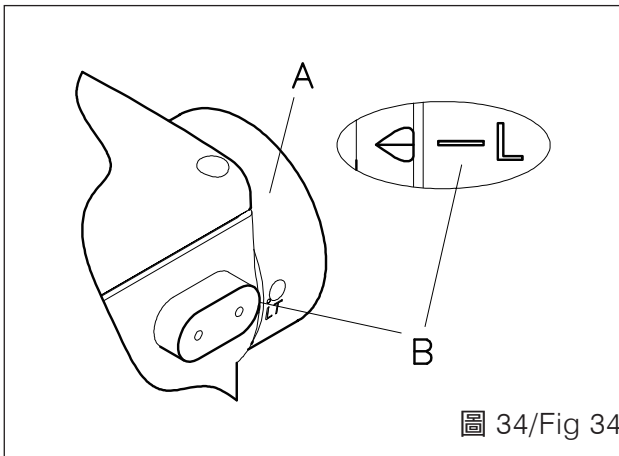

1. 針的前後位置調整，請參考前面的調整方式，使手輪 (A) 對準記號 (B)L，此時縫距為最大。(圖 34)

2. 請轉動手輪 (A)，針 (C) 由上往下時，針 (C) 的針孔上緣與送具孔面平齊時，送具 (D) 的孔與針的間隙為 0.8mm。(圖 35)

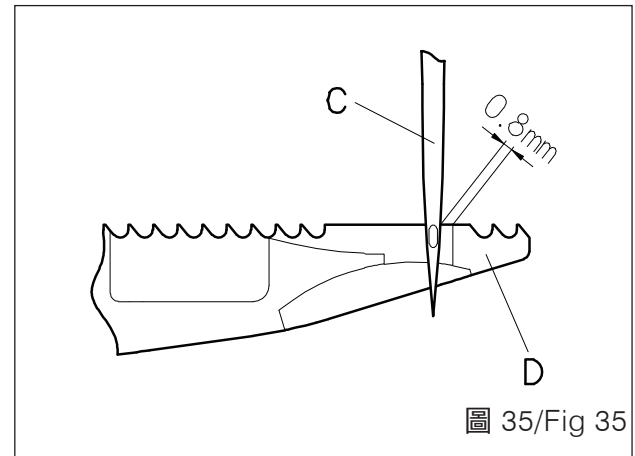

1.Adjusting of front-back position of the needle With reference to the previous adjustment method. Adjusting of stitch length, align the number L of pulley position to the mark (B). Then, the stitch length is maximum. (Fig 34)

2.When the needle (C) is going down from the top dead point by turning of hand pulley (A), align the top end of needle hole of the needle (C) to the top surface of the feed dog (D). The clearance between the needle and the needle drop hole of the feed dog (D) should be approx. 0.8mm. (Fig 35)



圖 36/ Fig 36

3. 調整針的前後位置時，請拆下橡膠塞 (E)，鬆開擺針棒 (F) 的固定螺絲 (G)，進行前後移動調整。(圖 36)
4. 針的前後運動量調整：要調整針與送具相對運動量時，請拆下下座之後蓋 (H) 及防油墊片 (I)，鬆開針擺棒銷 (J) 的螺帽 (K)，上下移動進行調整。  
\* 向上移動，針的運動量比送具大；向下移動則針的運動量比送具小。(圖 37)

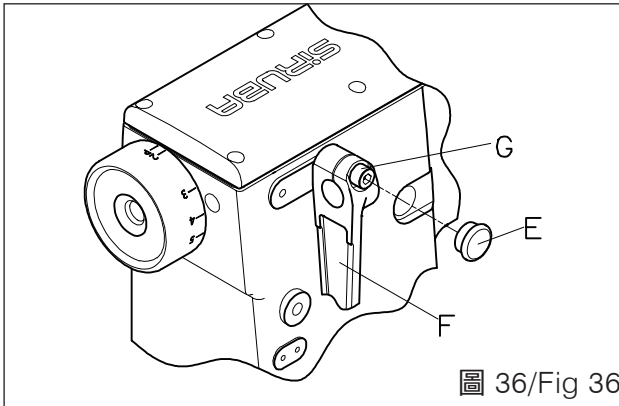

圖 37/ Fig 37

3. Remove the rubber plug (E) of the machine. Adjust the needle clamp with the moving to front and back after loosening of the screw (G) of the needle swing lever arm (F). (Fig 36)
4. Adjusting of front-back movement amount of the needle : when adjusting of the movement amount of the needle, remove the cover (H) and the gasket (I), moving up and down of the needle swing lever pin (J) after loosening of the nut (K).  
\* The needle feeding amount is increased when moving up. The needle feeding amount is decreased when moving down. (Fig 37)

## 壓腳的調整

## ADJUSTING THE PRESSER FOOT

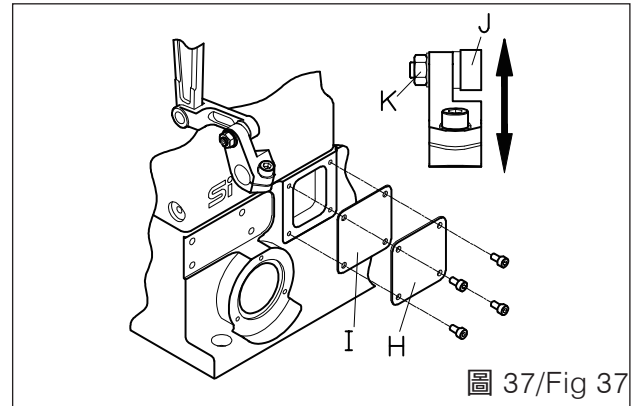

圖 38/ Fig 38

1. 壓腳壓力的調整：  
旋鈕 (A) 順時針方向旋轉壓力增大，逆時針方向旋轉壓力減小。(圖 38)
2. 壓腳最大高度為 9mm。(圖 39)

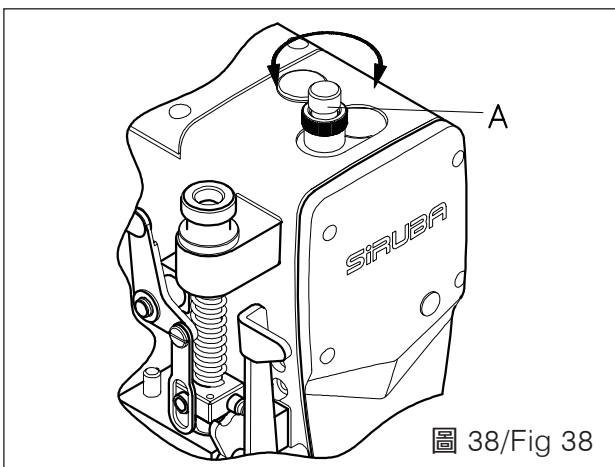

圖 39/ Fig 39

1. Presser foot pressure :  
To increase the presser foot pressure, turn the adjusting knob clockwise. (Fig 38)
2. The maximum height of the presser foot approximately 9mm. (Fig 39)

## 後滾輪裝置的調整

## ADJUSTING THE REAR PULLER DEVICE

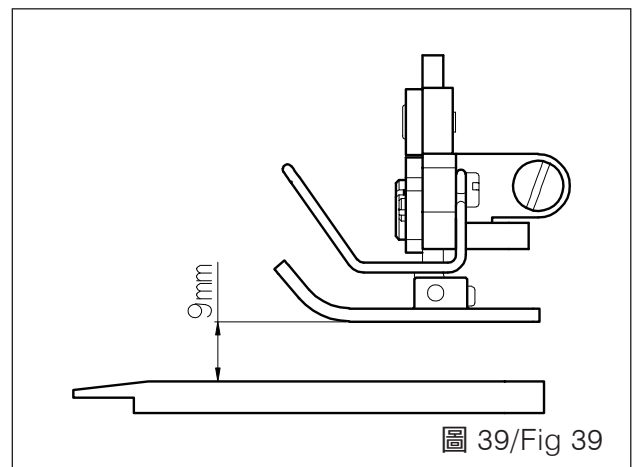
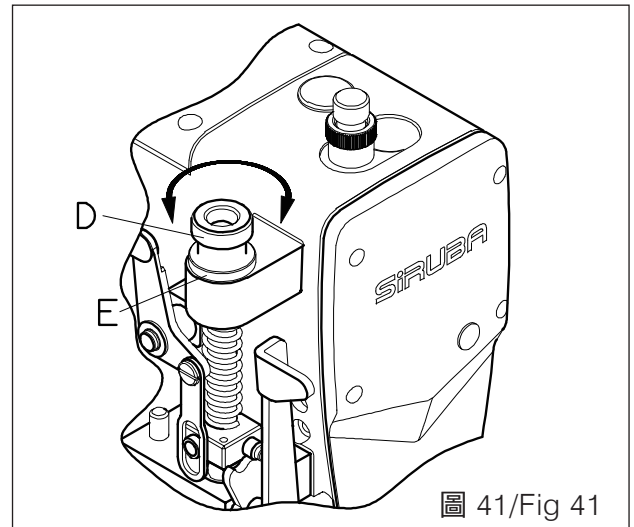
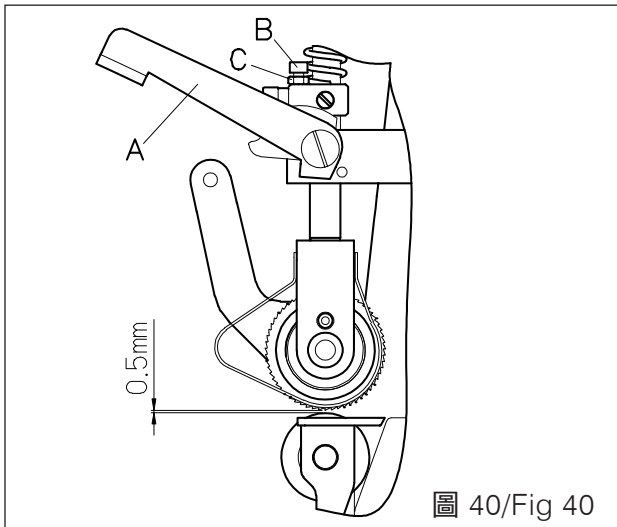

1. 手動桿 (A) 在下落的狀態，上滾輪與下滾輪之間為 0.5mm。將螺絲 (B) 調整到正確位置後，鎖緊螺帽 (C)。(圖 41)

1. With the manual lever (A) lowered, hold stopper (B) so that the clearance between the upper and lower pullers is 0.5mm. Then tighten nut (C). (Fig 41)

2. 後滾輪的壓力調整：  
調整螺絲 (D) 順時針旋轉時，壓力增加；  
逆時針旋轉時，壓力減少。調整完後請鎖緊螺帽 (E)。(圖 42)

2. To adjust the puller pressure :  
To increase the pressure, turn adjusting screw (D) clockwise. To decrease the pressure, turn adjusting screw (D) counterclockwise. Fasten the lock nut (E) after adjusting. (Fig 42)

3. 後滾輪送布量調整：(圖 42)  
調整時，鬆開螺帽 (F)，向上調整送布量變少，向下調整送布量變多，如果這種調整方式送布量過大或不夠時，請拆下橡膠塞 (G)，鬆開螺帽 (H)，向上調整送布量變少，向下調整送布量變多。

3. Adjusting the feeding amount of the rear puller : (Fig 42)  
To decrease the amount, loosen nut (F) and move it up. To increase the amount, loosen nut (F) and move it down.  
If the feeding amount is too large or small, remove the rubber plug (G) and loosen the nut (H).  
To decrease the amount, move it up.  
To increase the amount, move it down.

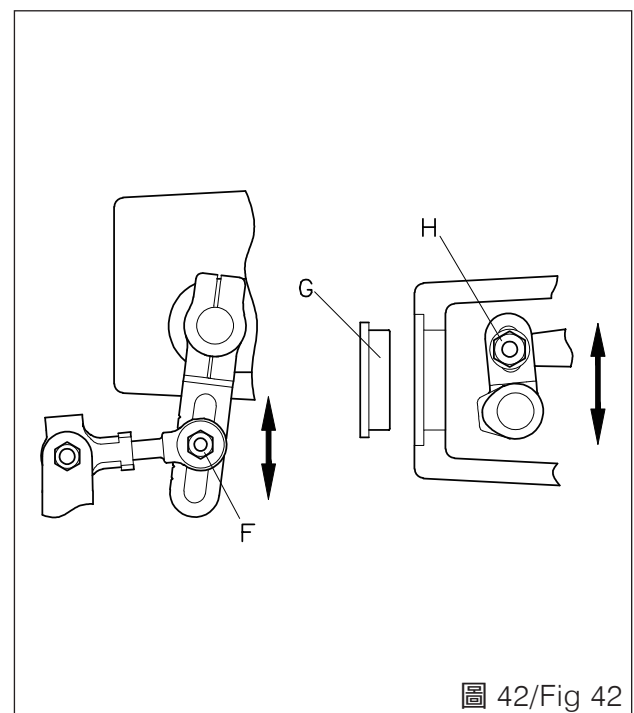



## 線跡狀態調整

## ADJUSTING THE STITCH FORMATION



圖 43/ Fig 43

1. 過線器 (A) 的位置是從固定螺絲 (B) 的中心算起約 11.5mm 前後。(圖 43)

2. 鬆線器與過線器的位置和調整：

過線器 (C) 在長直孔約中心處鎖緊固定螺絲 (D)，如果把過線器 (C) 往左調，線較鬆弛；如往右調，則線較緊繃。鬆線器 (E) 通過過線器 (C) 的中心位置後，鎖緊螺絲 (F)。(圖 44)

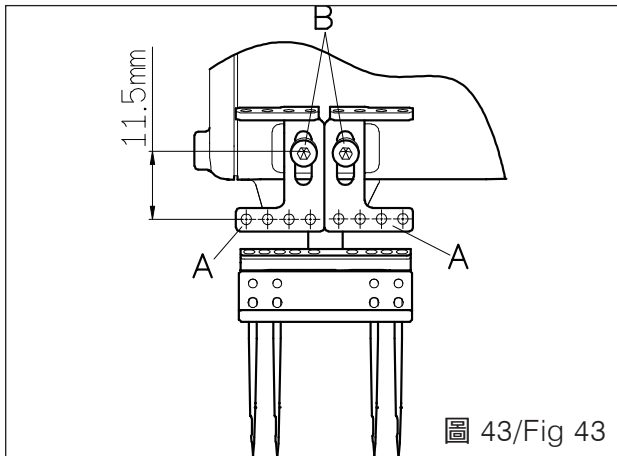

圖 44/ Fig 44

1. The position of the needle thread eyelet (A) should be adjusted about approx. 11.5mm from the center of the screw (B). (Fig 43)

2. Position of the looper thread take-up eyelet

The looper thread eyelet (C) is to be fastened by the screw (D) at the center of its long-hole. If turn the looper thread eyelet (C) to the left, line is relaxation. If turn the looper thread eyelet (C) to the right, line is tight.

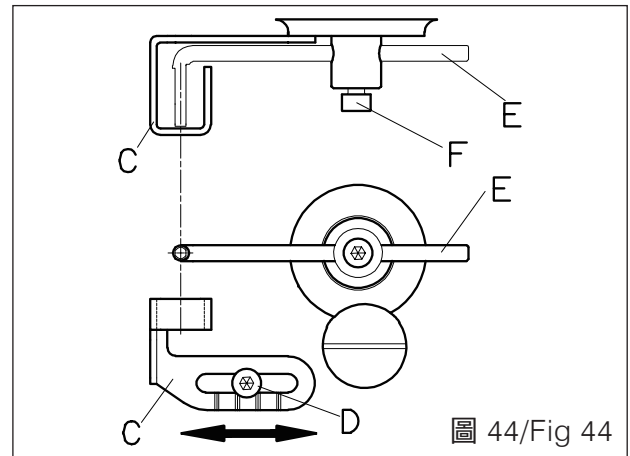
After the looper take-up (E) passes the center position of the looper thread eyelet (C), tighten the screw (F). (Fig 44)

單位/UNIT : mm  
 所有尺寸公差/TOLERANCE : ±2  
 長度(L) : 1200/重量(W) : 16.5kg±5%  
 桌板型式 : 上乘式  
 板厚 : 45mm

A





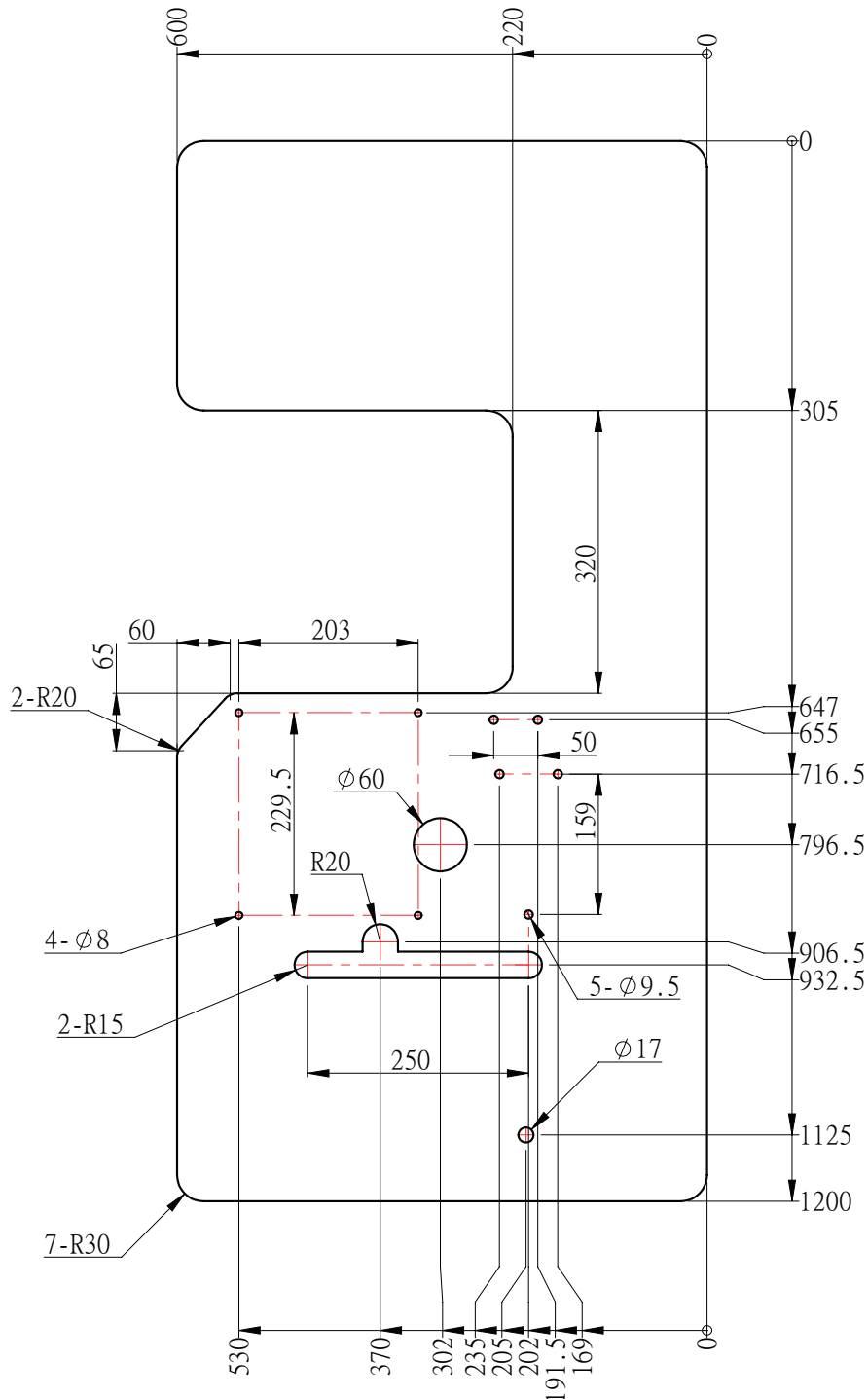

B

C

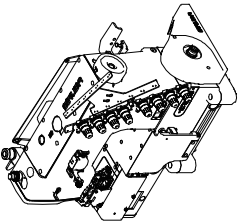
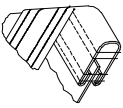
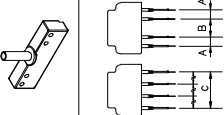
D

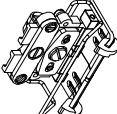
E

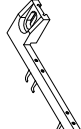
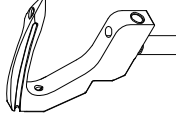
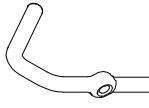

SIRUBA GAGE PARTS LIST		Series NC008		Remark		Page 1 / 1	Date 2020/04/24						
													
機 型 MODEL	種 類 NEEDLE GAUGE	針 座 NEEDLE HOLDER	針 板 NEEDLE PLATE	送 具 FEED DOG	押 具 PRESSER FOOT	勾 針 座 LOOPER HOLDER	撥 線 桿 SPREADER	勾 針 LOOPER	護 針 器 NEEDLE GUARD	護 針 片 THREAD GUIDE	針 號 NEEDLE		
NC008-02	1 1/4"	M8501	E8501	D8501	P8501-A	HD323	HF325-E						
NC008-02	1 1/2"	M8504	E8504	D8504	P8504-A	HD319	HF314-E						
NC008-04	1/4 1 1/4"	M8504	E8504	D8504	P8504-A	HD319	HF314-E						
NC008-04	1"	M8505	E8505	D8505	P8505-A	HD322	HF327-E	LP8504	LP8504A	D8504A	DVX57 #14~#25		
NC008-04/HPR	1/4 1 1/4"	M8504	E8504	D8504	P8504-A	HD319	HF314-E						
NC008-04/HPR	1/4 7/8 1/4"	M8502	E8502	D8502	P8502-A	HD324	HF326-E						
NC008-06	1/4"	M8512	E8512	D8512	P8512-A	HD321	HF320-E						

SIRUBA PARTS LIST	Series	Parts Group	Subclass Remark	Page
	NC008	HA		1 / 2
				Date
				2018/10/01

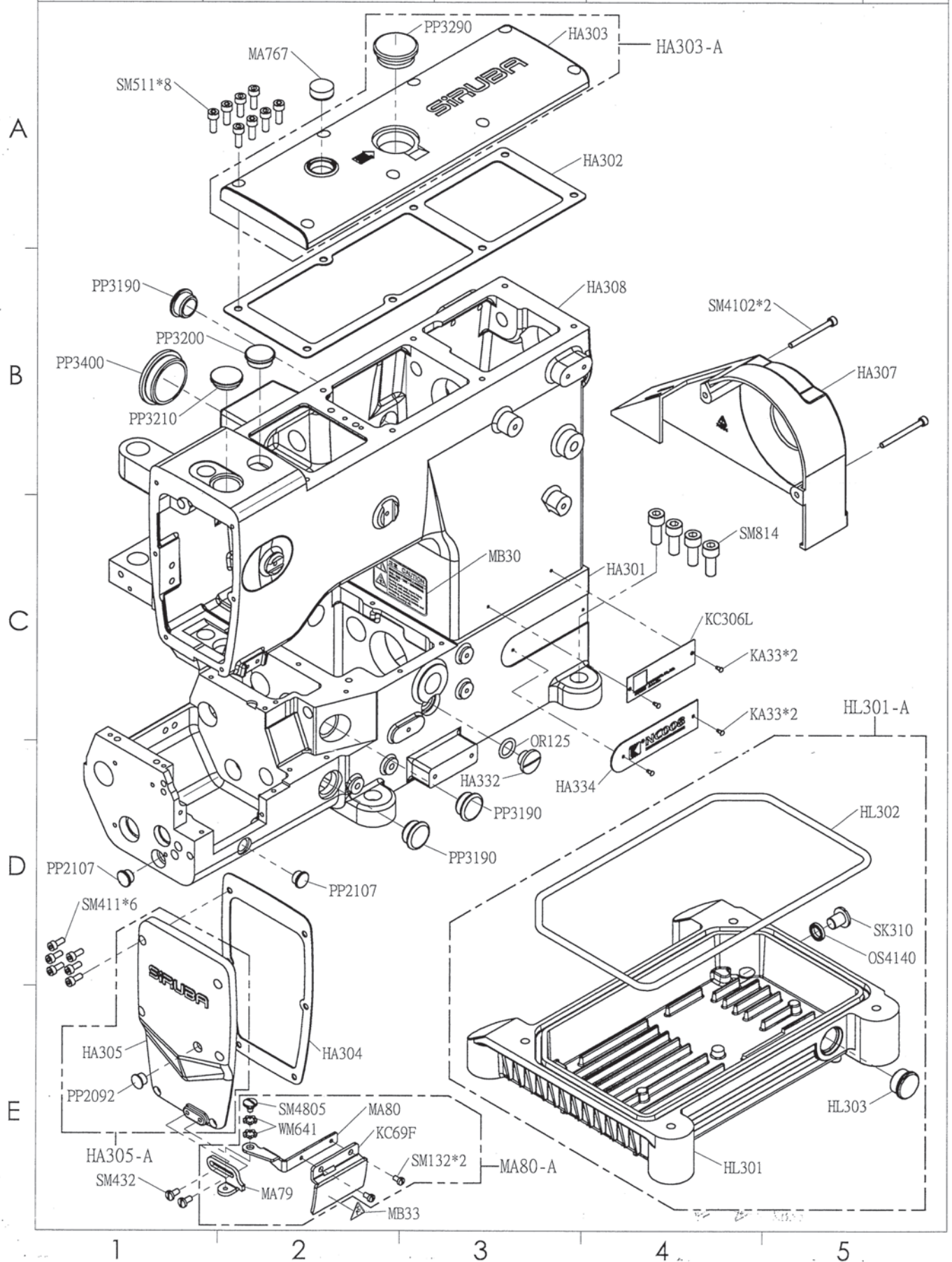

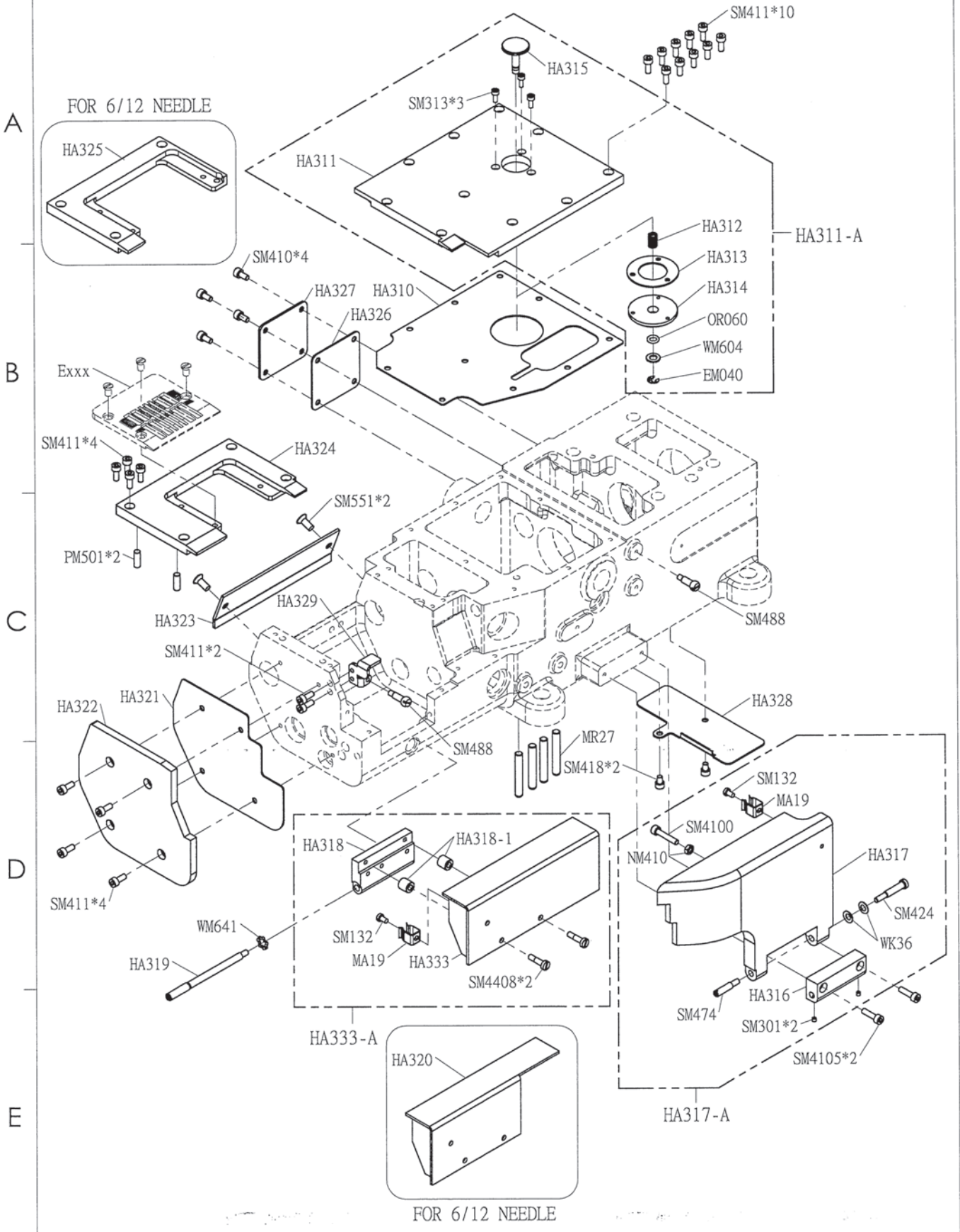

1 2 3 4 5

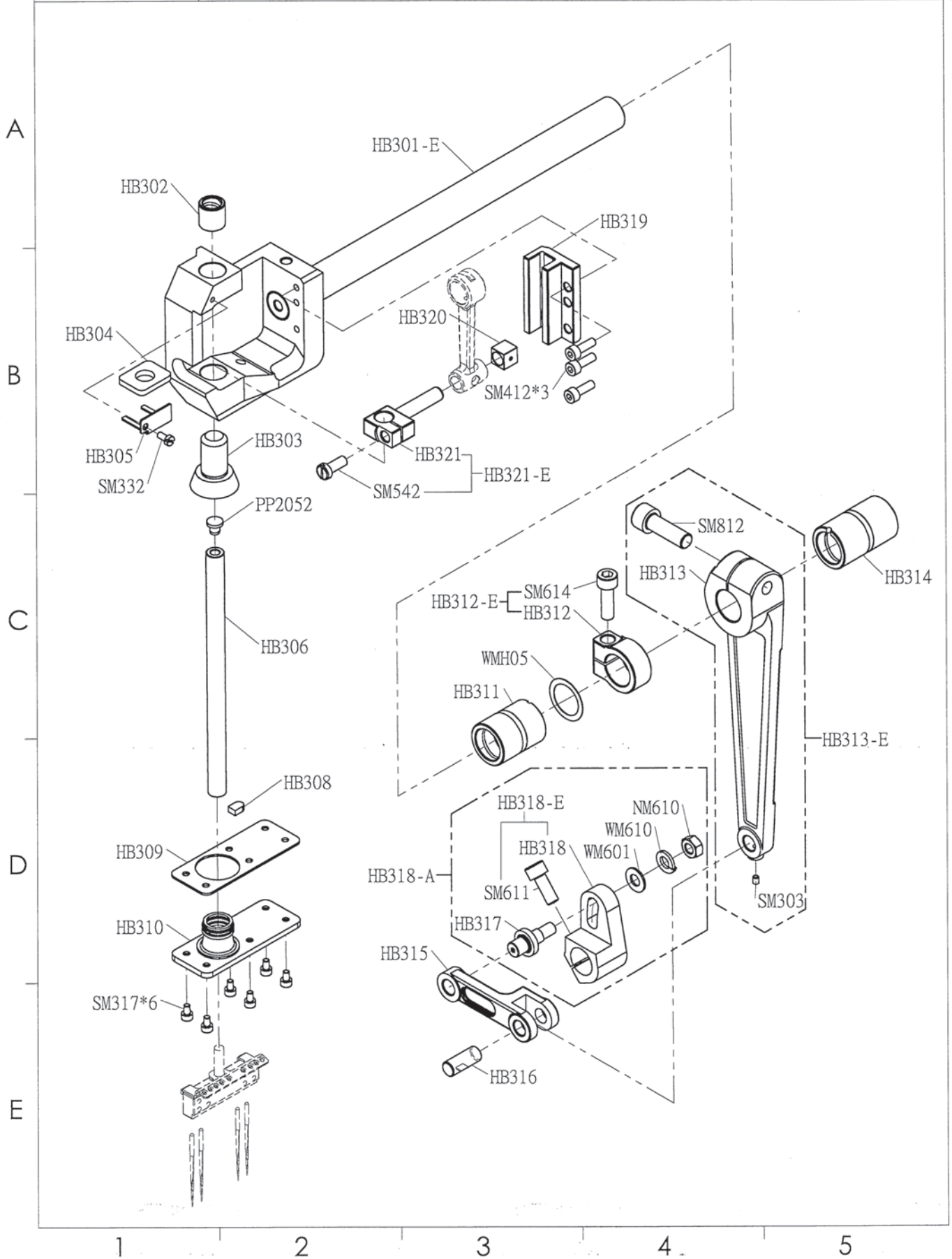

SIRUBA PARTS LIST	Series	Parts Group	Subclass Remark	Page
	NC008	HB		2/2
				Date
				2018/10/01

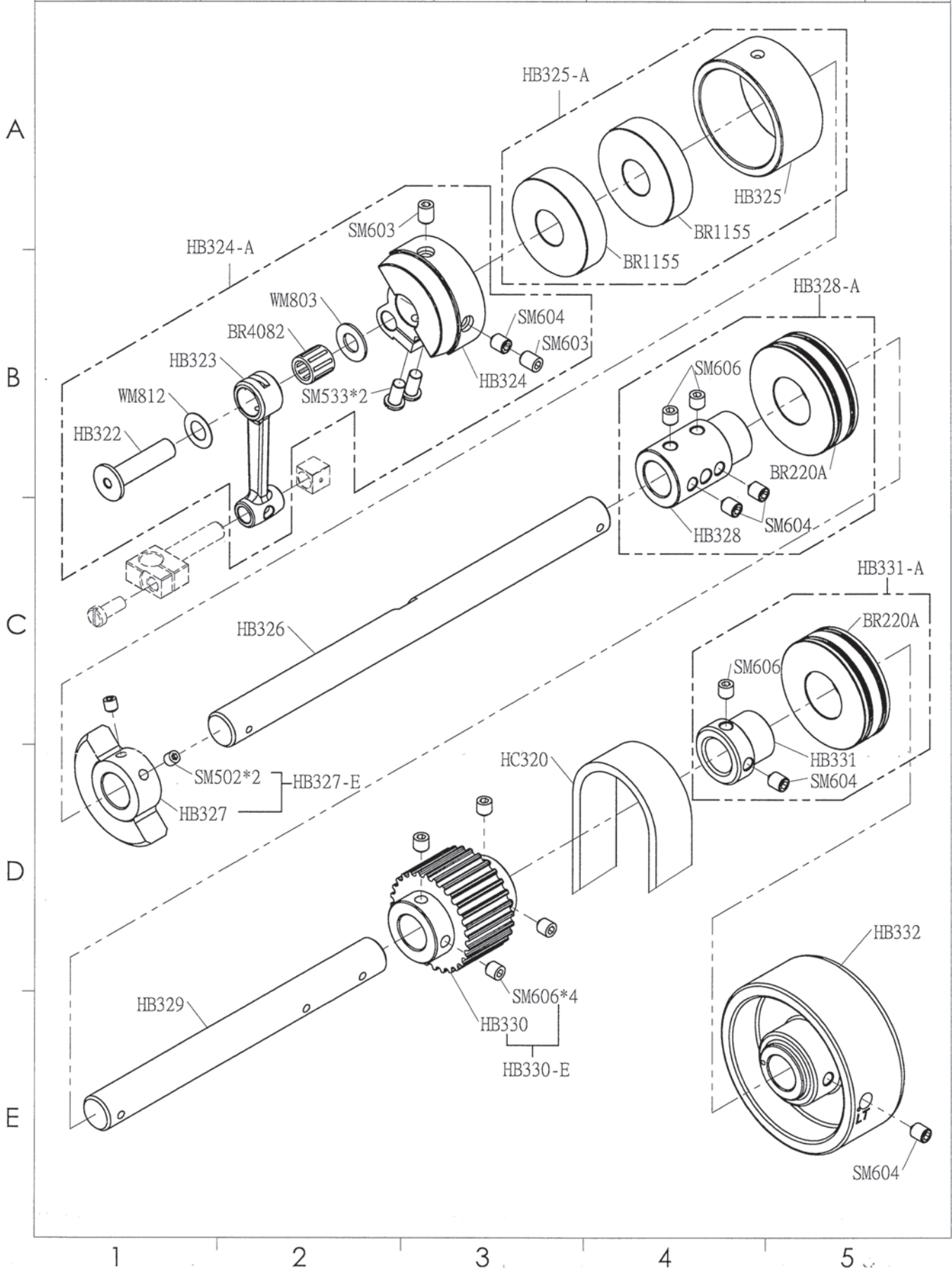

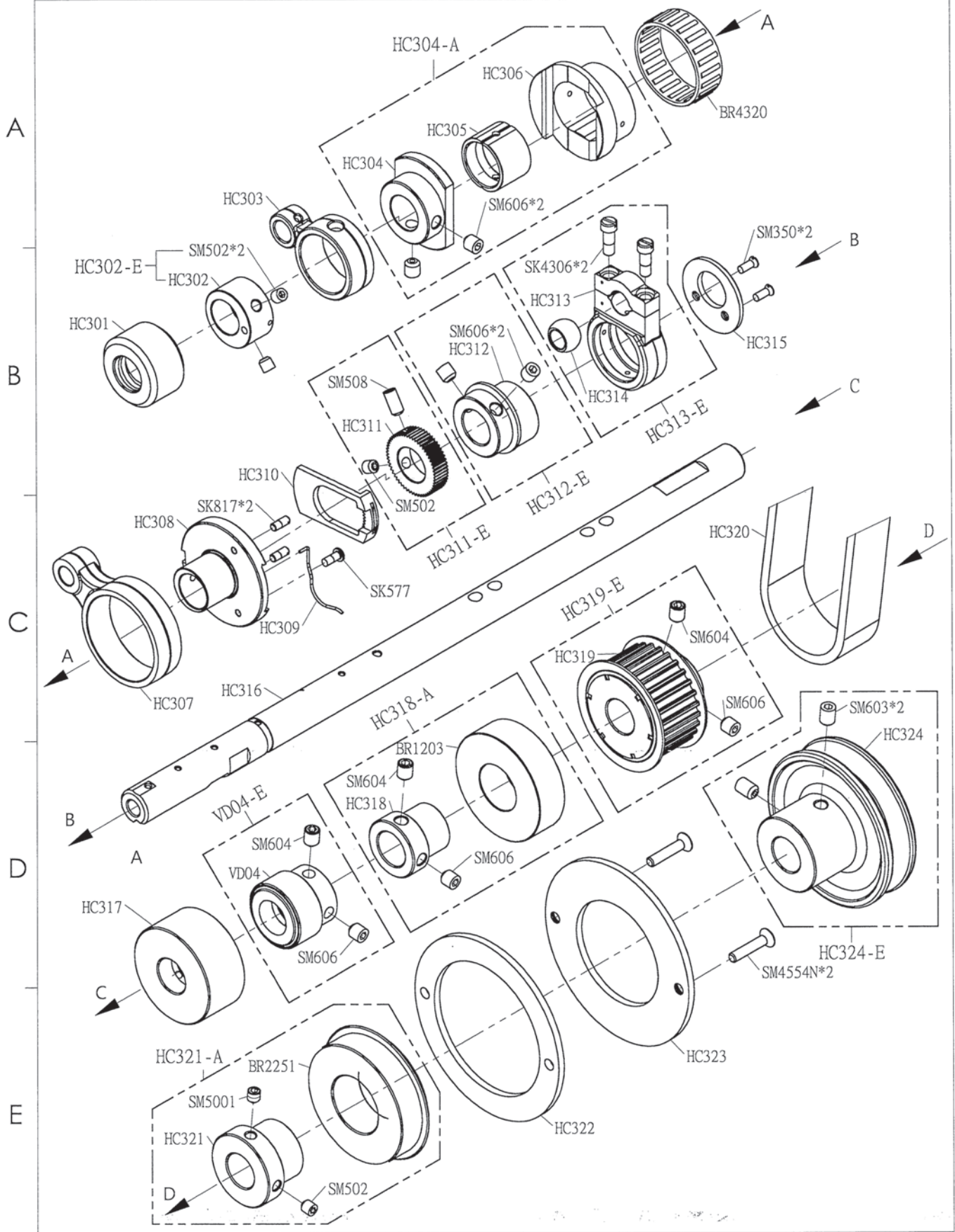



<b>SIRUBA</b> PARTS LIST	Series	Parts Group	Subclass Remark	Page
	<b>NC008</b>	<b>HD</b>		1 / 1
				Date
				2018/10/01

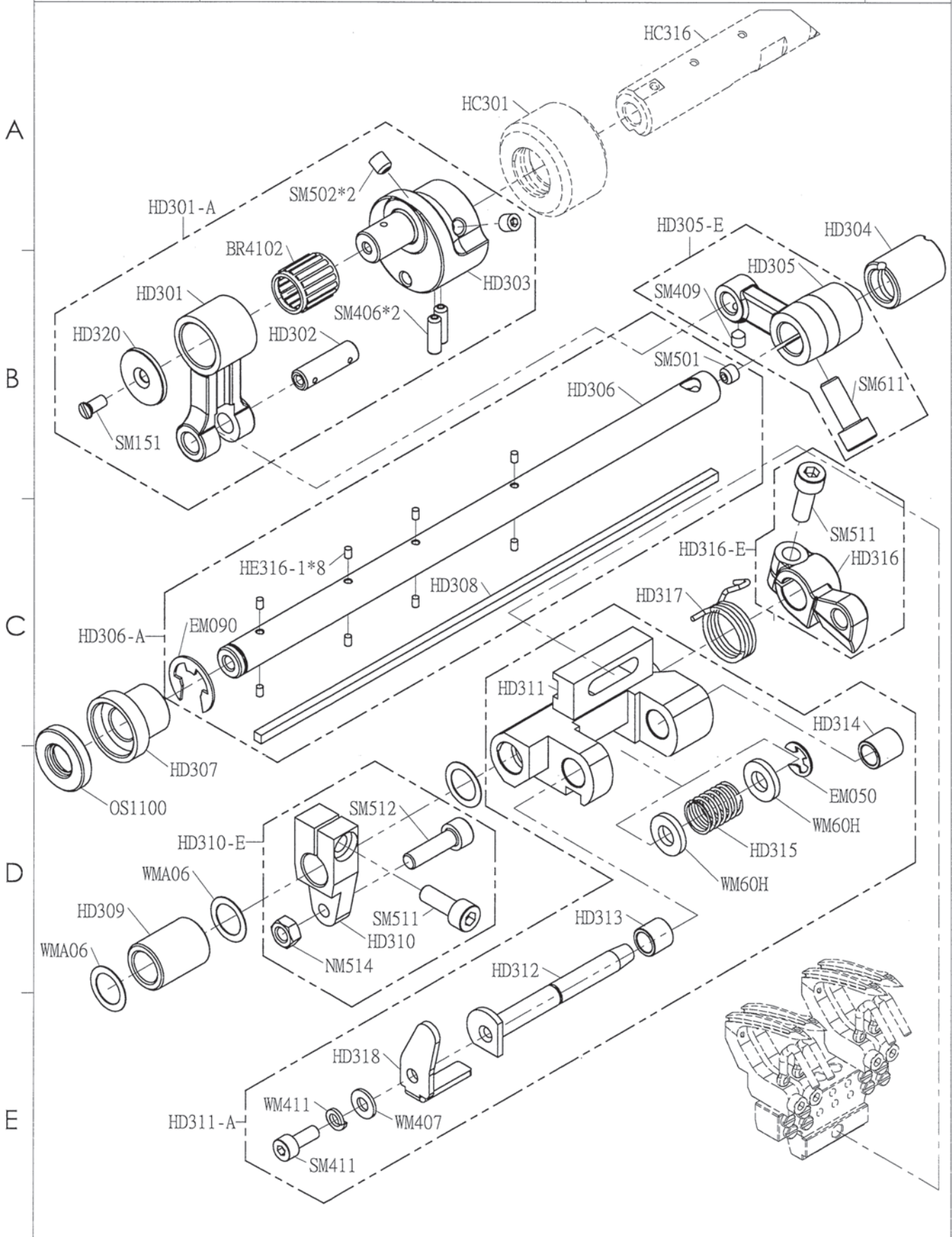

SIRUBA PARTS LIST	Series	Parts Group	Subclass Remark	Page
	NC008	HE		1 / 1
				Date
				2018/10/01

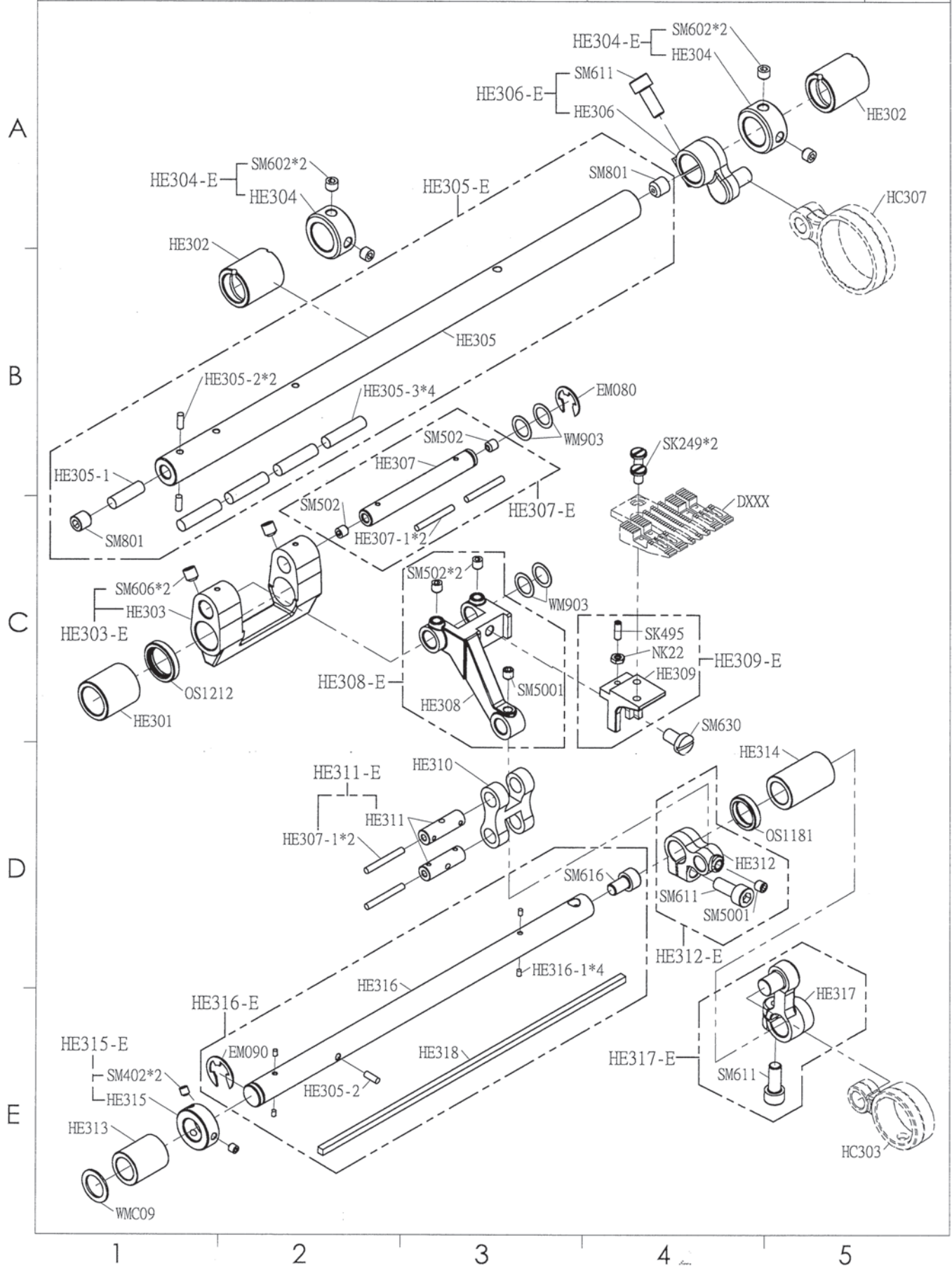

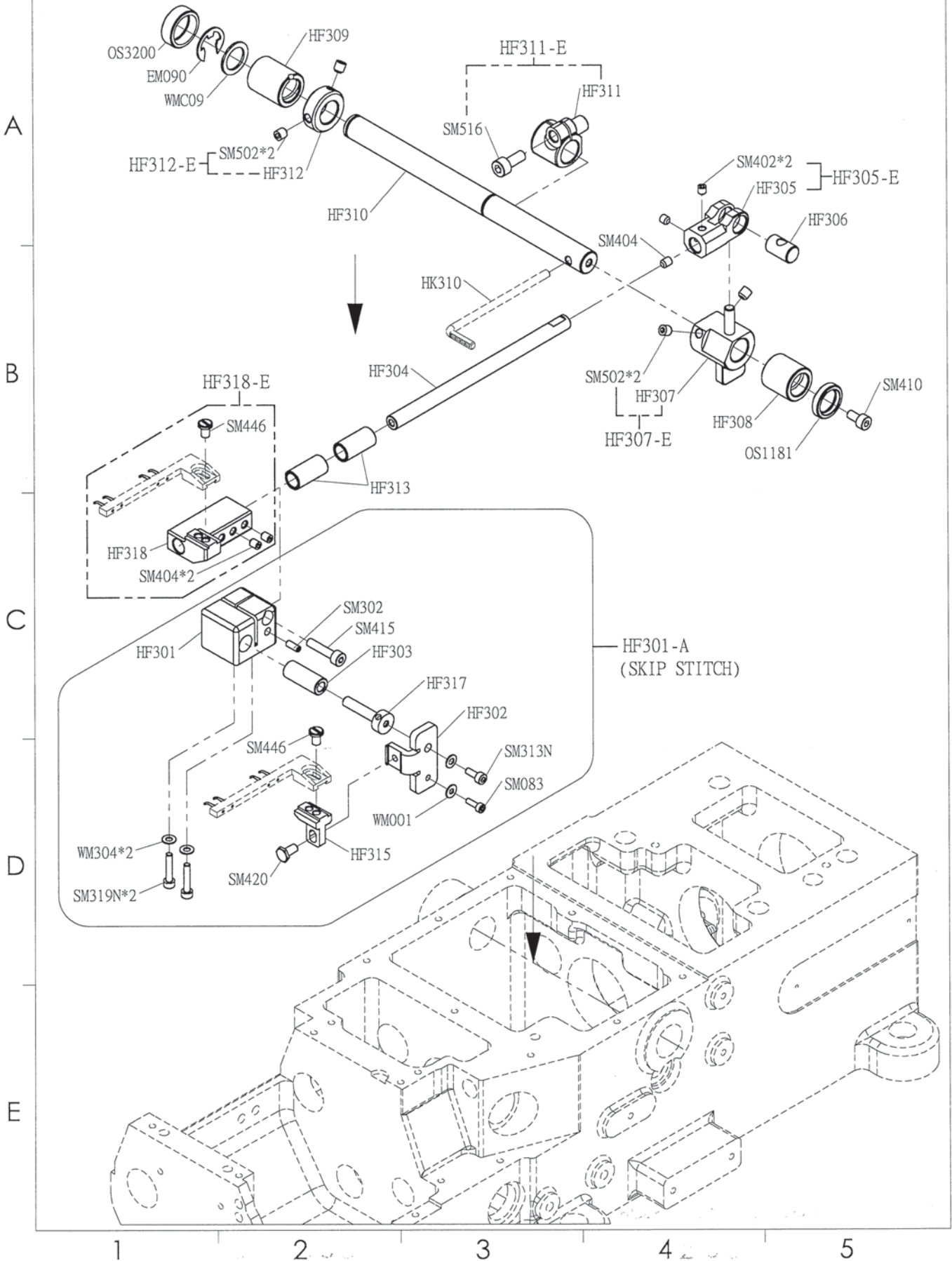

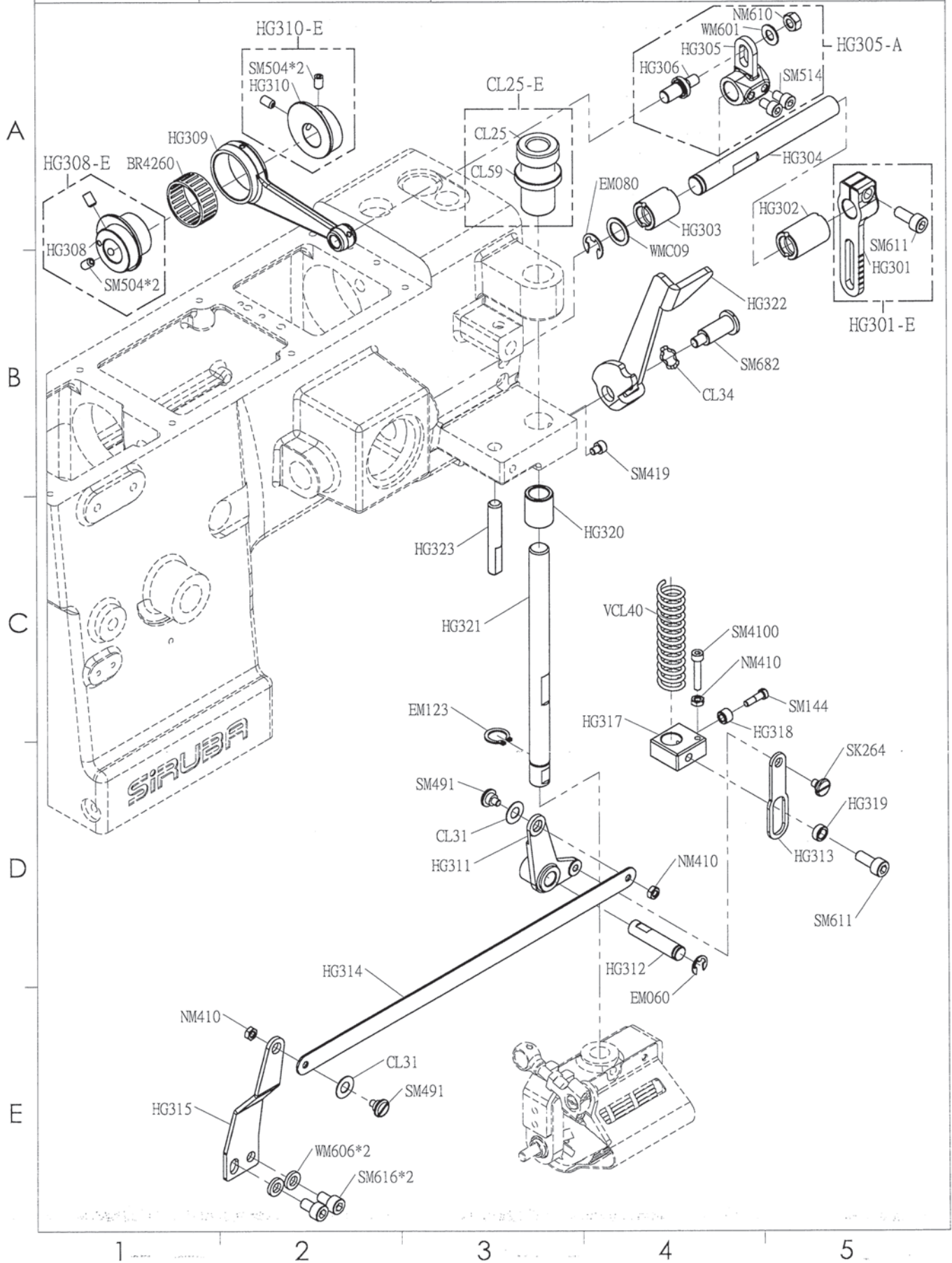

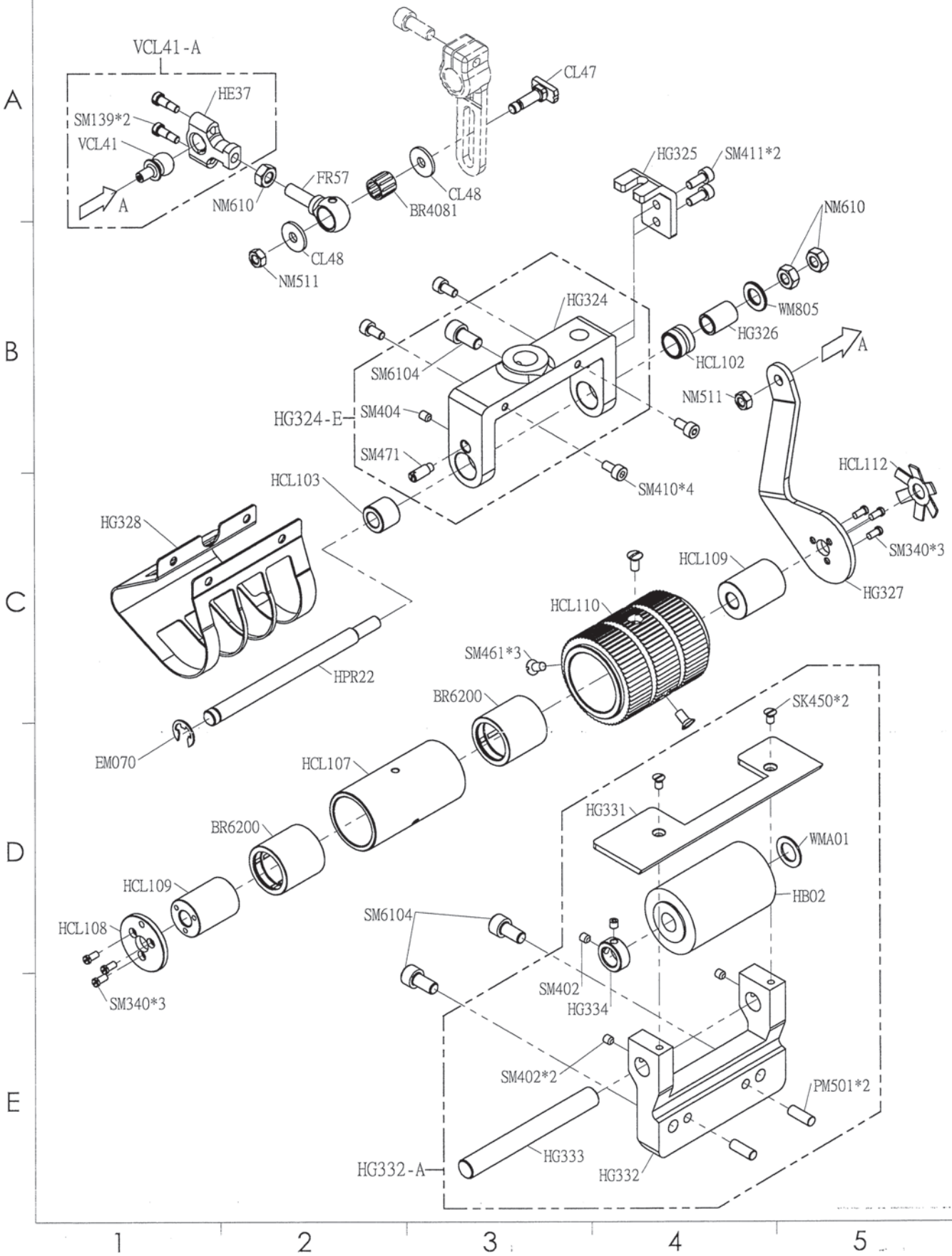

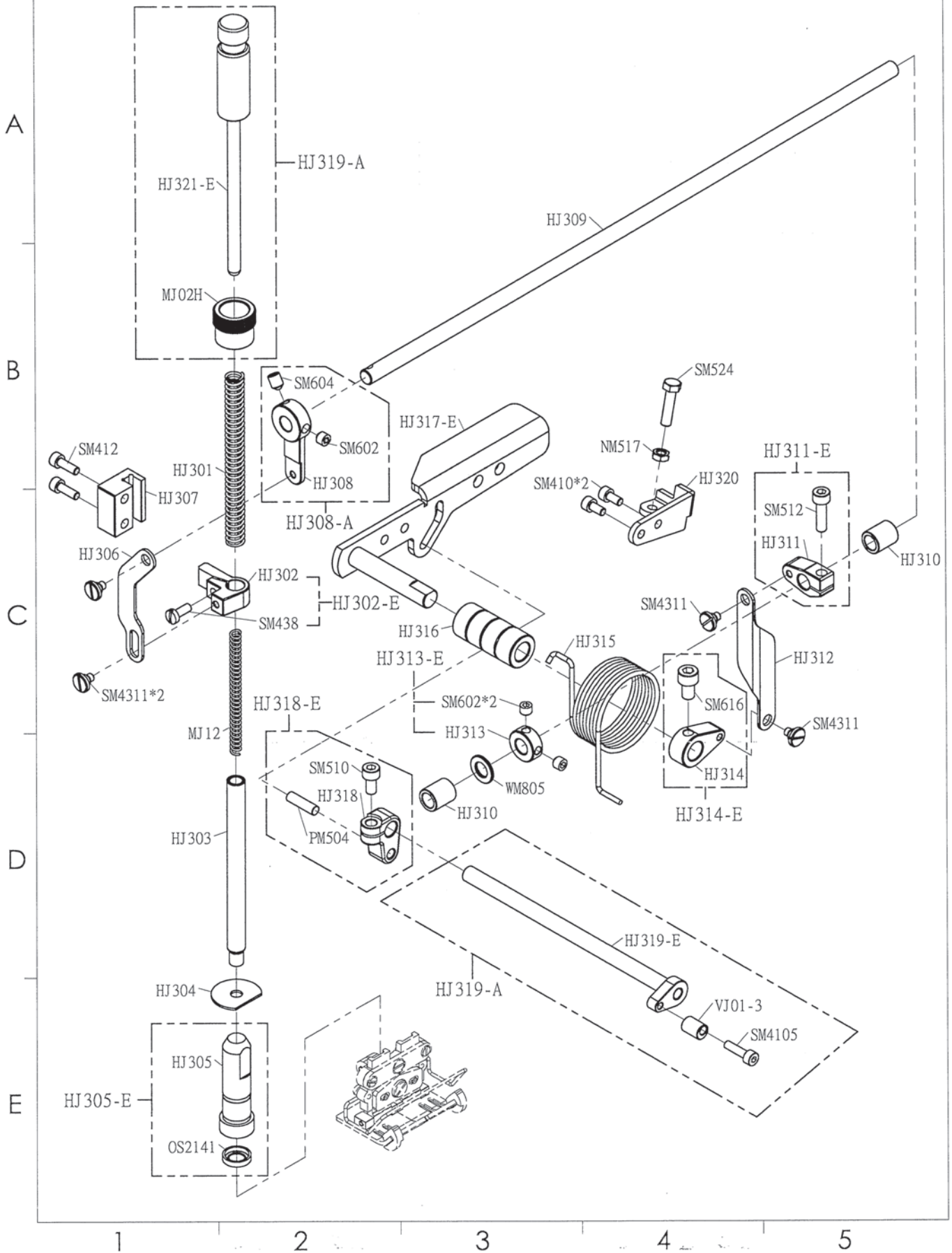

(FOR 4 NEEDLE)

A

B

C

D

E

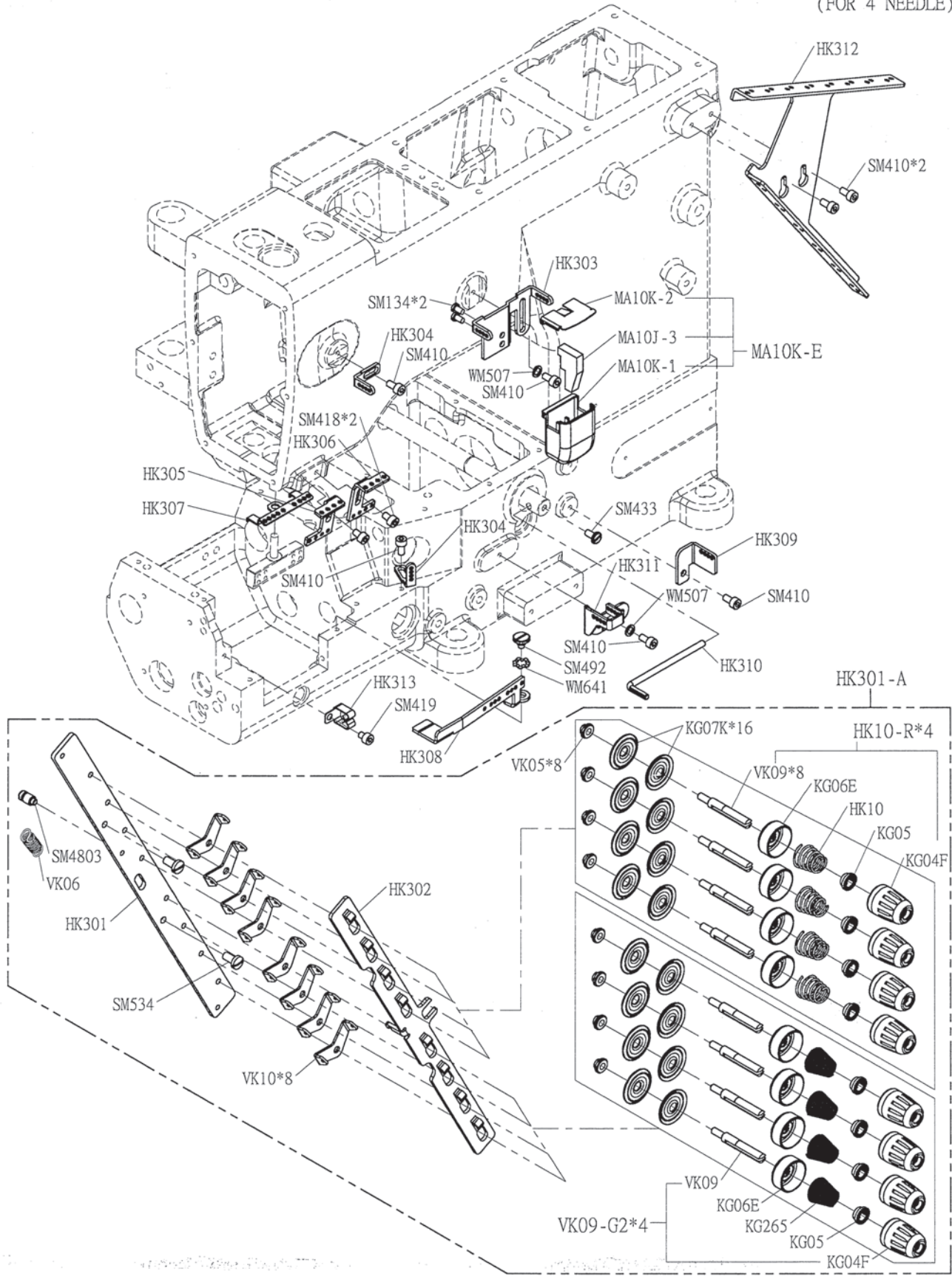

1

2

3

4

5

(FOR 6/12 NEEDLE)

A

B

C

D

E

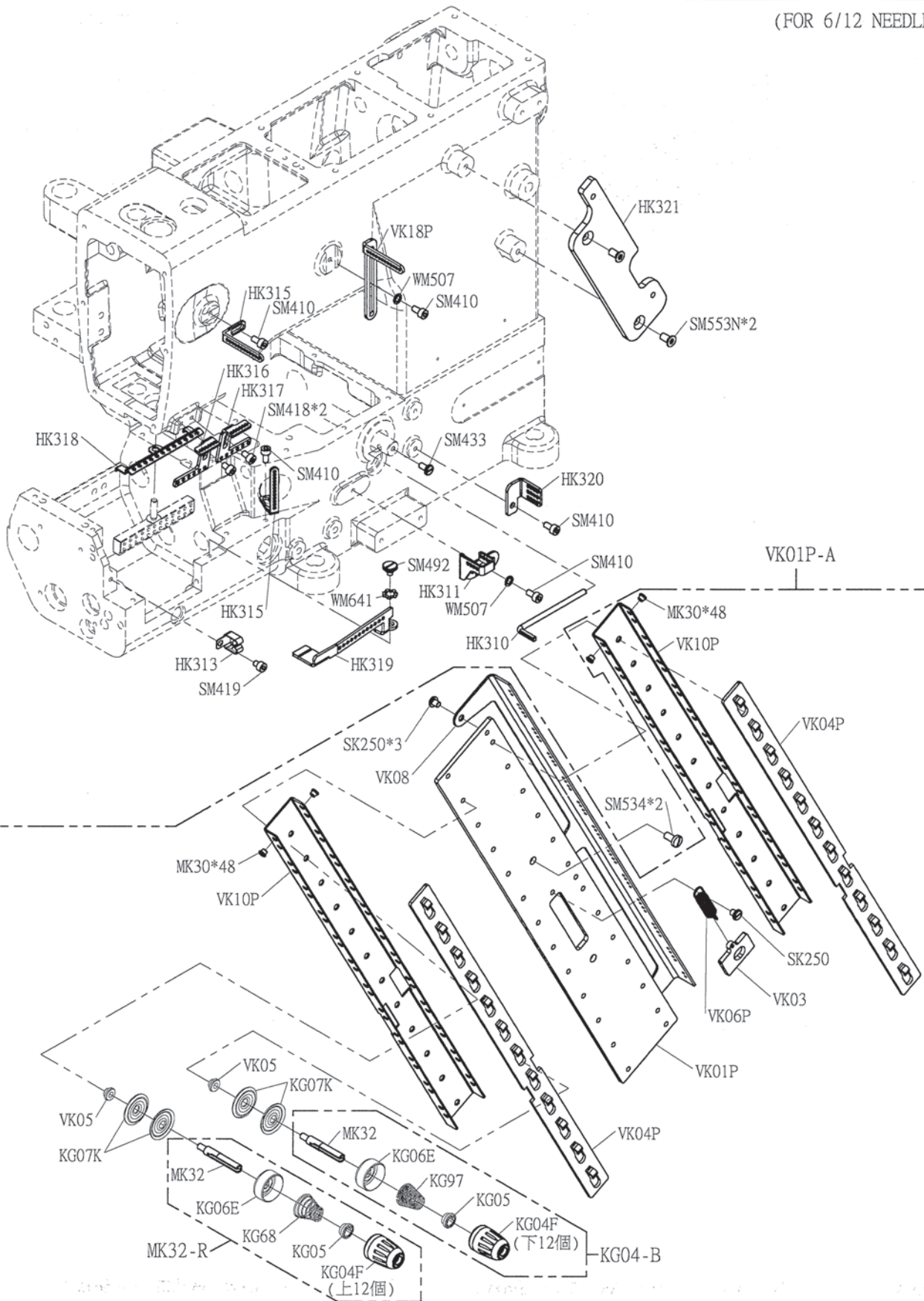

1

2

3

4

5



SIRUBA PARTS LIST	Series	Parts Group	Subclass Remark	Page
	NC008	HL		1 / 1
			Date	2018/10/01

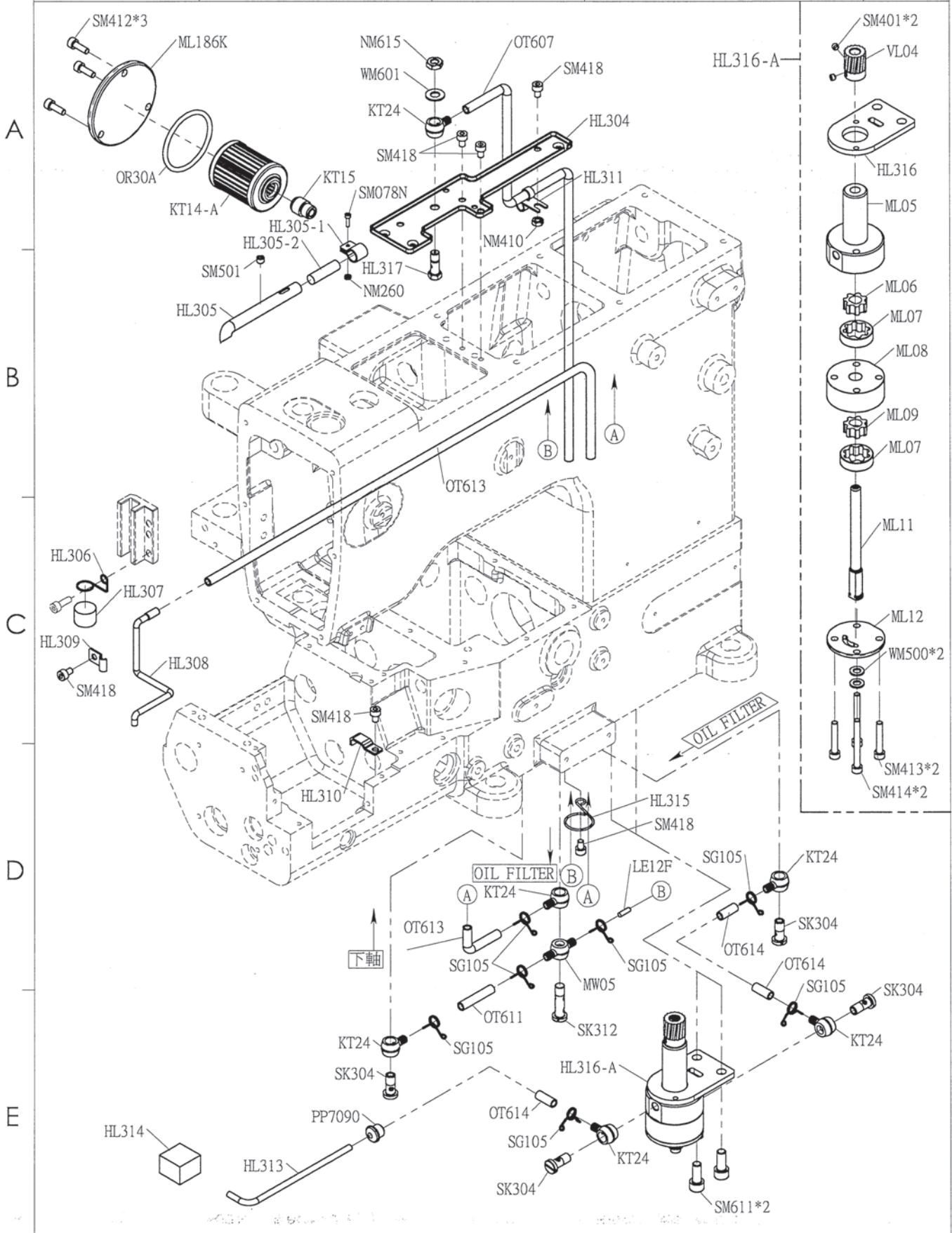

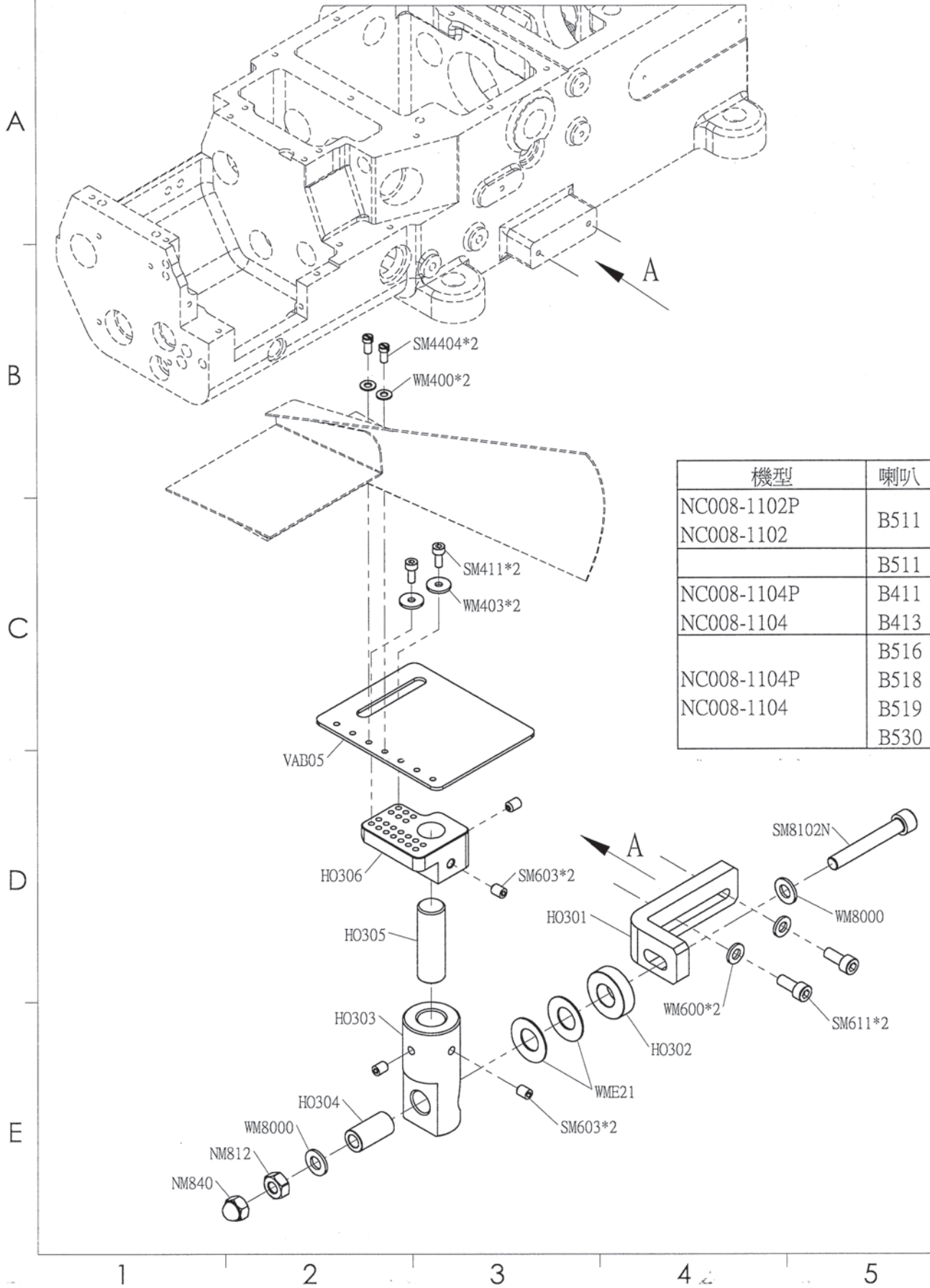

機型	喇叭
NC008-1102P	B511
NC008-1102	B511
NC008-1104P	B411
NC008-1104	B413
NC008-1104P	B516
NC008-1104P	B518
NC008-1104	B519
NC008-1104	B530

(FOR 4 NEEDLE)

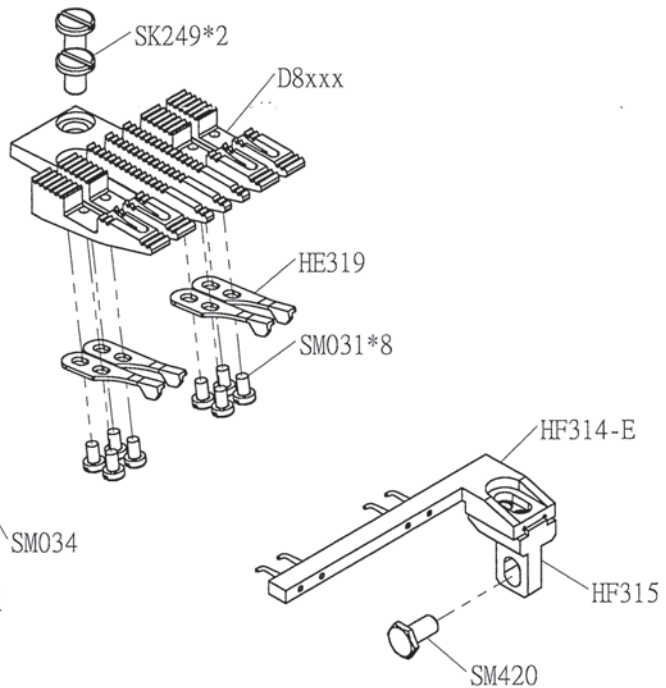
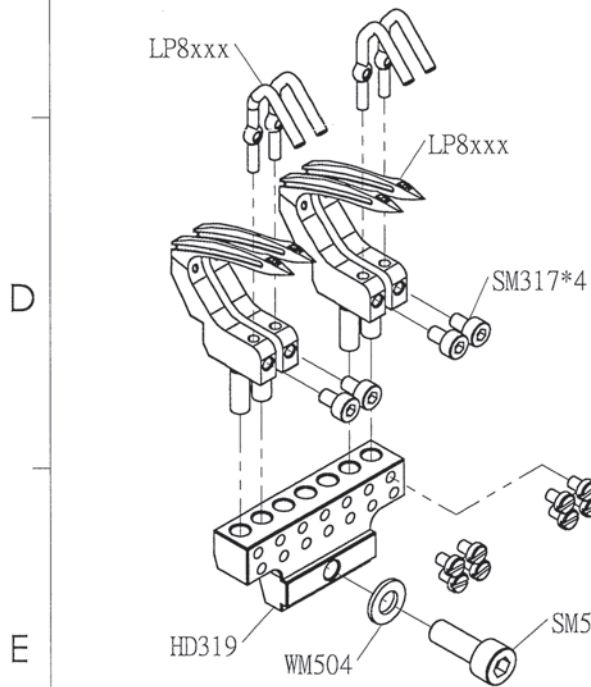
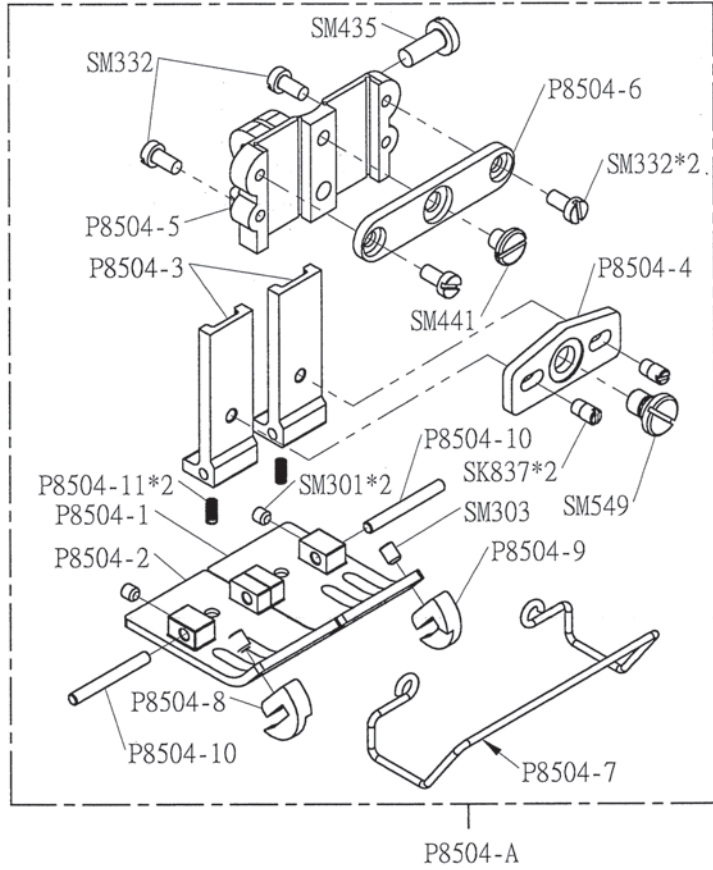
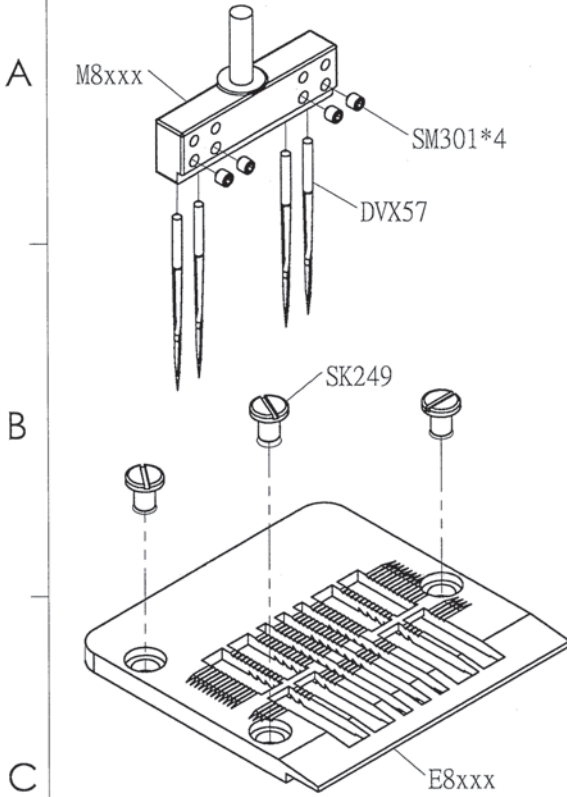

(FOR 6/12 NEEDLE)

A

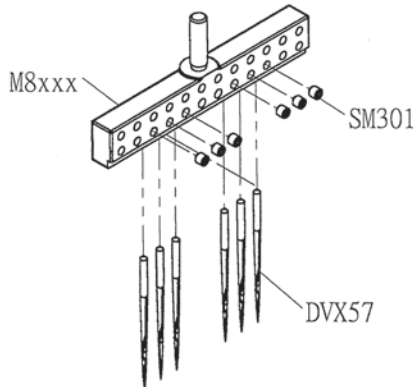

B

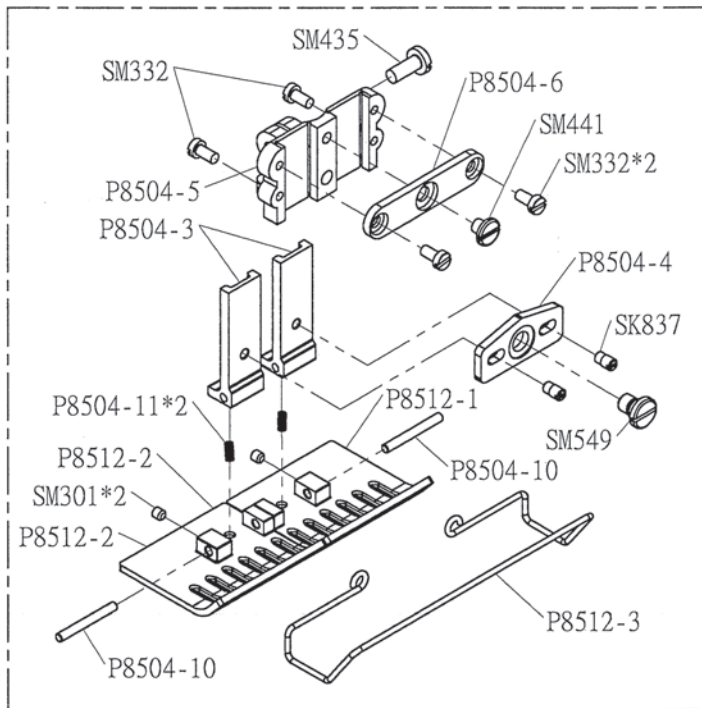

P8512-A

C

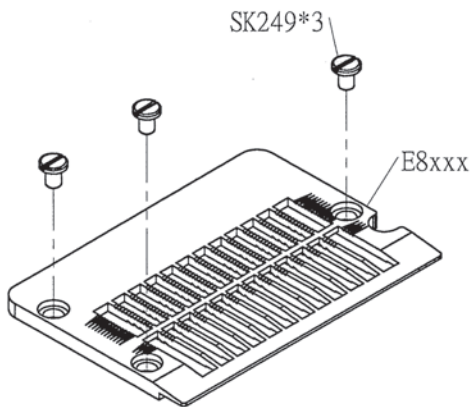

D

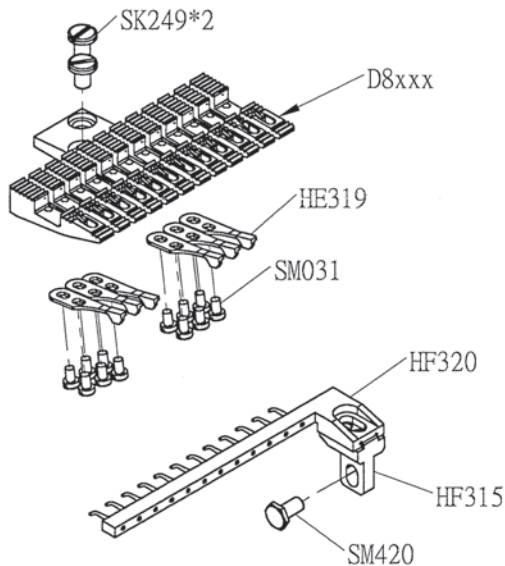
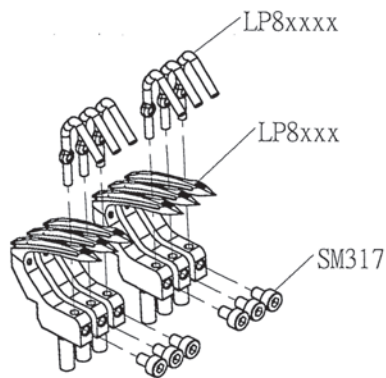

E

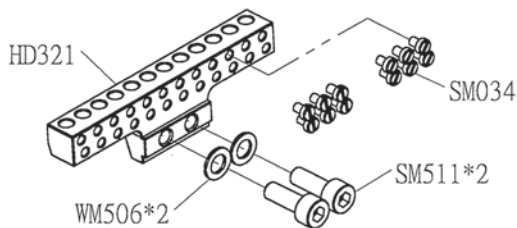

1

2

3

4

5

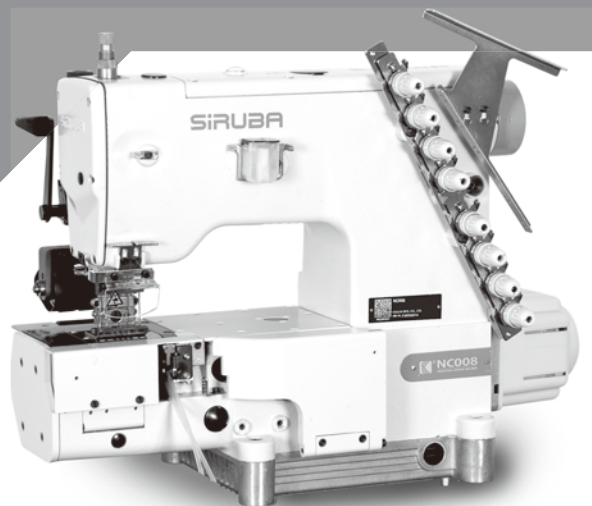

高林股份有限公司  
KAULIN MFG. CO., LTD.

由於對產品的改良及更新，本產品使用說明書中與零件圖之產品及外觀的修改恕不事先通知！  
The specification and/or appearances of the equipment described in this instruction book & parts list are subject to change because of modification which will without previous notice.  
NC008.JAN.2021